

Charles University in Prague
1st Faculty of Medicine

Doctoral Studies in Biomedicine
Biochemistry and Pathobiochemistry



MUDr. PhDr. Oskar Zakiyanov

Novel Biomarkers in Patients with Renal Disease

Nové biomarkery u pacientů s onemocněním ledvin

PhD Thesis

Supervisor: Prof. MUDr. Marta Kalousová, Ph.D.

Prague, 2013

PROHLÁŠENÍ

Prohlašuji, že jsem závěrečnou práci zpracoval/a samostatně a že jsem řádně uvedl a citoval všechny použité prameny a literaturu. Současně prohlašuji, že práce nebyla využita k získání jiného nebo stejného titulu.

Souhlasím s trvalým uložením elektronické verze mé práce v databázi systému meziuniverzitního projektu Theses.cz za účelem soustavné kontroly podobnosti kvalifikačních prací.

V Praze, 16.12.2013

Jméno – Příjmení (hůlkovým písmem)

Podpis

IDENTIFIKAČNÍ ZÁZNAM

ZAKIYANOV, Oskar. *Nové biomarkery u pacientů s onemocněním ledvin. [Novel biomarkers in patients with renal disease]*. Praha, 2013. 120 s., 5 příl. Disertační práce (Ph.D.). Univerzita Karlova v Praze, 1. lékařská fakulta, Ústav lékařské biochemie a laboratorní diagnostiky. Vedoucí práce: Kalousová, Marta.

ACKNOWLEDGEMENT

First I would like to express my profound respect and gratitude to prof. MUDr. Marta Kalousová, Ph.D, Professor of Biochemistry, 1st Medical Faculty, Charles University in Prague, Czech Republic, my supervisor and tutor for providing me this sophisticated project. Her professional guidance, mentorship and general optimistic attitude made it possible to overcome obstacles in everyday work, presentations, and thesis writing. Her advice, clear vision and patience were invaluable. She has given me the utmost support which led to the fact that I acquired a taste for medical research.

I also want to express my sincere gratitude to prof. MUDr. Vladimír Tesař, DrSc., MBA, FASN, FERA, Professor of Medicine, 1st Medical Faculty, Charles University in Prague, Czech Republic, Head of the Department of Nephrology, who offered best possible conditions for performing clinical research in his department, as well as for his encouragement, valuable support and constant feedback.

Special thanks go to MUDr. Ing, Vítězslav Kříha, Ph.D., Head of the Department of Physics, Faculty of Electrical Engineering, Czech Technical University in Prague, Czech Republic, for his assistance in statistical evaluation of the thesis research work, and all the time he has invested in long discussions on many aspects of this work.

I also express my gratitude to prof. MUDr. Tomáš Zima, DrSc., MBA, Professor of Biochemistry, 1st Medical Faculty, Charles University in Prague, Czech Republic, Head of the Department of Medical Chemistry and Laboratory Diagnostics, for many helpful suggestions.

Furthermore I want to thank all the physicians and nurses and laboratory staff for the good ambience at the Department of Nephrology and Institute of Clinical Biochemistry and Laboratory Diagnostics, 1st Faculty of Medicine, Charles University in Prague. A special thank to laboratory staff Mrs. Dita Hudcová, Mrs. Helena Miškovská, and RNDr. Jana Švarcová, Ph.D. for technical assistance. I am equally thankful to nurses from outpatient department and dialysis centre, especially to Bc. Martina Růžičková, Mrs. Hana Čejková, and Bc. Magdalena Bartková.

I am particularly grateful to all the patients willing to collaborate in this project.

During the time I focused on this study I must admit that this has not been possible without constant supportive and encouraging environment given by my family, especially my beloved mother Galiya Zakiyanova.

This study was supported by research projects and by grants: the grant from the Internal Grant Agency of the Czech Ministry of Health NS/10043-4/2008; the research project MSM 00216202807; the research project of Charles University P25/LF/1/2; the grants SVV 2011-262512, SVV 2012-264511 and SVV 2013-266515.

TABLE OF CONTENTS

<i>Prohlášení</i>	II
<i>Identifikační záznam</i>	III
<i>Acknowledgement</i>	IV
<i>List of figures</i>	VIII
<i>List of tables</i>	VIII
<i>Abstrakt</i>	IX
<i>Klíčová slova</i>	IX
<i>Abstract</i>	X
<i>Key words</i>	X
<i>Abbreviations</i>	XI
1 INTRODUCTION	1
1.1 OUTLINE.....	1
1.2 CHRONIC KIDNEY DISEASE, OXIDATIVE STRESS, ATHEROSCLEROSIS, MICRO-INFLAMMATION AND CARDIOVASCULAR RISK... 2	2
1.3 ACUTE KIDNEY INJURY.....	7
1.4 OVERVIEW OF NOVEL BIOMARKERS.....	10
1.4.1 <i>Placental growth factor</i>	11
1.4.2 <i>Pregnancy associated plasma protein A</i>	14
1.4.3 <i>Matrix metalloproteinases, matrix metalloproteinase 2, matrix metalloproteinase 9</i>	16
1.4.4 <i>Soluble receptor for advanced glycation end products (sRAGE)</i>	19
1.4.5 <i>Extracellular newly identified RAGE binding protein (EN-RAGE) or the calcium binding protein S100A12</i>	21
1.4.6 <i>High Mobility Group Box protein-1 (HMGB-1)</i>	23
1.4.7 <i>Emerging biomarkers in chronic kidney disease and acute kidney injury: future perspectives</i>	25
2 AIMS OF THE STUDY	27
3 MATERIAL AND METHODS	28
3.1 METHODS.....	28
3.1.1 <i>Enzyme immunoassay for the quantitative determination of PIGF in human serum</i>	28
3.1.2 <i>Enzyme immunoassay for the quantitative determination of RAGE in human serum</i>	30
3.1.3 <i>Enzyme immunoassay for the quantitative determination of MMP-2 in human serum</i>	33
3.1.4 <i>Enzyme immunoassay for the quantitative determination of MMP-9 in human serum</i>	35
3.1.5 <i>Time Resolved Amplified Cryptate Emission immunofluorescent assay for the quantitative determination of PAPP-A in human serum</i>	38
3.1.6 <i>Enzyme immunoassay for the quantitative determination of S100A12/EN-RAGE in human serum</i>	39
3.1.7 <i>Enzyme immunoassay for the quantitative determination of HMGB-1 in human serum</i>	42
3.1.8 <i>Measurement of other parameters</i>	43
3.2 SUBJECTS.....	44
3.2.1 <i>Placental growth factor in patients with chronic kidney disease</i>	44
3.2.2 <i>Serum S100A12 (EN-RAGE) Levels in Patients with Decreased Renal Function and Subclinical Chronic Inflammatory Disease</i>	46
3.2.3 <i>Determinants of Circulating MMP-2 and PAPP-A in Patients with Chronic Kidney Disease</i>	47
3.2.4 <i>Changes of MMP-2, MMP-9, PAPP-A in patients with various nephropathies</i>	48
3.2.5 <i>Evaluation of PIGF, PAPP-A, sRAGE, EN-RAGE and HMGB-1 levels in patients with acute kidney injury</i>	49
3.3 STATISTICAL ANALYSIS.....	51

3.3.1	<i>PlGF in patients with decreased renal function</i>	51
3.3.2	<i>Serum S100A12 (EN-RAGE) Levels in Patients with Decreased Renal Function and Subclinical Chronic Inflammatory Disease</i>	51
3.3.3	<i>Determinants of Circulating MMP-2 and PAPP-A in Patients with Chronic Kidney Disease</i>	51
3.3.4	<i>Changes of MMP-2, MMP-9, PAPP-A in patients with various nephropathies</i>	52
3.3.5	<i>Evaluation of PlGF, PAPP-A, sRAGE, EN-RAGE and HMGB-1 levels in patients with acute kidney injury</i>	52
4	RESULTS	53
4.1	ELEVATION OF PLGF IN PATIENTS WITH DECREASED RENAL FUNCTION	53
4.2	LEVELS OF EN-RAGE IN PATIENTS WITH DECREASED RENAL FUNCTION AND SUBCLINICAL CHRONIC INFLAMMATORY DISEASE	56
4.3	BIOCHEMICAL DETERMINANTS OF PAPP-A AND MMP-2 IN PATIENTS WITH CHRONIC KIDNEY DISEASE.....	59
4.4	SPECIFIC CHANGES OF MMP-2, MMP-9, PAPP-A IN PATIENTS WITH CHRONIC KIDNEY DISEASE	64
4.5	PLGF, PAPP-A, sRAGE, EN-RAGE AND HMGB-1 LEVELS IN PATIENTS WITH ACUTE KIDNEY INJURY	67
5	DISCUSSION	74
5.1	THE IMPACT OF CIRCULATING LEVELS OF PLGF, PAPP-A, MMP-2, MMP-9, sRAGE, EN-RAGE, AND HMGB-1 IN PATIENTS WITH CHRONIC KIDNEY DISEASE	74
5.1.1	<i>PlGF in patients with decreased renal function</i>	74
5.1.2	<i>Serum S100A12 (EN-RAGE) Levels in Patients with Decreased Renal Function and Subclinical Chronic Inflammatory Disease</i>	77
5.1.3	<i>Biochemical determinants of PAPP-A and MMP-2 in patients with CKD</i>	81
5.1.4	<i>Changes in serum levels of MMP-2, MMP-9 and PAPP-A in patients with various nephropathies</i> . 84	
5.2	EVALUATION OF NOVEL BIOMARKERS (PLGF, PAPP-A, sRAGE, S100A12 (EN-RAGE), AND HMGB-1 IN PATIENTS WITH ACUTE KIDNEY INJURY	88
6	CONCLUSION	93
7	REFERENCES	95
8	PUBLICATIONS OF THE AUTHOR	118
8.1	LIST OF PUBLICATIONS THAT FORMED THE BASIS FOR THE THESIS.....	118
8.2	LIST OF OTHER PUBLICATIONS.....	118
9	APPENDIX	120

LIST OF FIGURES

Fig. 1 AKI criteria; according to [83].....	8
Fig. 2 Stem-cell recruitment and mobilization in the bone marrow by PlGF, and sites of inhibition by VEGFR-1 blocking antibodies (Reprinted by permission from Macmillan Publishers Ltd: Nature Medicine 8, 775-777 (2002) [115].....	12
Fig. 3 Local control of IGF signaling by cell-associated PAPP-A. (Reprinted by permission from Elsevier Ltd: Trends in Endocrinology and metabolism 23, 242-249 (2012) [143].....	14
Fig. 4 PAPP-A induced macrophage activation; (Reprinted by permission from Elsevier Ltd: Trends in Endocrinology and metabolism 23, 242-249 (2012) [143].	15
Fig. 5 Domain structures of the MMP family [155].	16
Fig. 6 S100A12 can perpetuate inflammatory mechanisms; (Reprinted by permission from Elsevier Inc: Clinical Immunology 147, 229-241 (2013) [199].....	23
Fig. 7 Serum PlGF levels in patients with chronic kidney disease and various degrees of decreased renal function (CHRI, HD patients, and healthy subjects).....	54
Fig. 8 Correlation of serum PlGF levels and their detectable in the urine PlGF levels in CKD patients.....	55
Fig. 9 Correlation of log MMP-2 and log proteinuria in CKD patients (1-5).....	61
Fig. 10 Correlation of log MMP-2 and albumin in CKD patients (1-5).....	62
Fig. 11 Correlation of log PAPP-A and log proteinuria in CKD patients (1-5).....	62
Fig. 12 Correlation of log PAPP-A and albumin in CKD patients (1-5).....	63
Fig. 13 Serum PlGF-A levels of AKI, CKD5, HD and control groups.....	69
Fig. 14 Serum PAPP-A levels of AKI, CKD5, HD and control groups.....	70
Fig. 15 Serum sRAGE levels of AKI, CKD5, HD and control groups.....	70
Fig. 16 Serum sRAGE levels of AKI, CKD5, HD and control groups.....	71
Fig. 17 Serum levels of AKI, CKD5, HD and control groups.....	71

LIST OF TABLES

Table 1 GFR and Albuminuria Categories in the New Classification.....	3
Table 2 Maladaptive responses that exacerbate ischemic acute kidney injury.....	9
Table 3 Clinical and laboratory data of control subjects and patients with decreased renal function.....	53
Table 4 Clinical and laboratory data of control subjects and patients with decreased renal function.....	57
Table 5 Factors associated with S100A12 (EN-RAGE) in all studied groups.....	58
Table 6 Clinical, demographic and laboratory characteristics of the study group and controls ...	60
Table 7 Factors associated with MMP-2. Multivariate regression analysis using serum MMP-2 as the dependent variable (adjusted to age, eGFR).....	64
Table 8 Factors associated with PAPP-A. Multivariate regression analysis using serum PAPP-A as the dependent variable (adjusted to age, eGFR).....	64
Table 9 Demographic and clinical characteristics of the subjects.....	66
Table 10 Baseline laboratory values in the six groups of various nephropathies compared with healthy controls.....	67
Table 11 Clinical and laboratory data of control subjects, AKI, CKD 5 and HD patients.....	68
Table 12 Univariate correlations between biomarkers and other variables.....	72
Table 13 Associations of PlGF, PAPP-A, EN-RAGE and HMGB-1 levels in AKI patients (multivariate regression analysis).....	73

ABSTRAKT

Chronické onemocnění ledvin a akutní poškození ledvin patří mezi významné zdravotní problémy v populaci. Je důležité, abychom byli schopni rozpoznat osoby s vysokým rizikem nepříznivého vývoje zdravotního stavu, progresí onemocnění a přidružených kardiovaskulárních komplikací. Cílem disertační práce bylo studium nových perspektivních biomarkerů, jejich vztah k renální funkci, chronickému zánětu, případně zvýšenému kardiovaskulárnímu riziku. Studovány byly: placentární růstový faktor (PIGF), s těhotenstvím asociovaný protein A (PAPP-A), matrixová metalloproteináza 2 (MMP-2), matrixová metalloproteináza 9 (MMP-9), solubilní receptor pro konečné produkty pokročilé glykace (sRAGE), protein vázající vápník S100A12 – nově identifikovaný extracelulární protein vázající se na receptor pro konečné produkty pokročilé glykace (EN-RAGE) a amfoterin (HMGB-1) u pacientů se sníženou funkcí ledvin včetně pacientů s chronickým renálním onemocněním, hemodialyzovaných, pacientů s akutním poškozením ledvin a zdravých kontrol pro srovnání. První studie odhalila, že hladina PIGF je zvýšená u pacientů se sníženou funkcí ledvin. Druhá studie zjistila spojitost hladin MMP-2 a PAPP-A s proteinurií u pacientů s chronickým renálním onemocněním. Sérové hladiny MMP-2, MMP-9 a PAPP-A se výrazně lišily u pacientů s různými nefropatiemi. Hladiny EN-RAGE nebyly zvýšeny v souvislosti se sníženou funkcí ledvin, ale byly spojeny se zánětlivými stavy. U pacientů s akutním renálním onemocněním byly hladiny PAPP-A, EN-RAGE a HMGB-1 výrazně zvýšené, ale PIGF a sRAGE nebyly zvýšené. Hladiny PAPP-A korelovaly s markery nutriční, PIGF, EN-RAGE a HMGB-1 vykazovaly významnou korelaci se zánětlivými parametry. V souhrnu tyto studie prokázaly možnost využití nových biomarkerů u pacientů s onemocněním ledvin.

KLÍČOVÁ SLOVA

akutní poškození ledvin, biomarkery, chronické onemocnění ledvin, chronický zánět, kardiovaskulární riziko, endoteliální dysfunkce, placentární růstový faktor, s těhotenstvím asociovaný protein A, matrixová metalloproteináza 2, matrixová metalloproteináza 9, solubilní receptor pro konečné produkty pokročilé glykace, protein vázající vápník S100A12 – nově identifikovaný extracelulární protein vázající se na receptor pro konečné produkty pokročilé glykace, amfoterin, hemodialýza, malnutrice, oxidační stres.

ABSTRACT

Chronic kidney disease (CKD) and acute kidney injury (AKI) are major public health problems. It is important to be able to identify those at high risk of adverse outcome, CKD progression and associated cardiovascular disease. The aim of the thesis was to study novel promising biomarkers, their relationship to kidney function, chronic inflammation and/or cardiovascular risk – placental growth factor (PIGF), pregnancy associated plasma protein A (PAPP-A), matrix metalloproteinase 2 (MMP-2), matrix metalloproteinase 9 (MMP-9), soluble receptor for advanced glycation end products (sRAGE), calcium binding protein S100A12 or extracellular newly identified RAGE binding protein (EN-RAGE), and high mobility group box protein-1 (HMGB-1) in patients with renal diseases including CKD, haemodialysis (HD), AKI patients, and healthy controls for comparison. First study revealed that PIGF is elevated in patients with decreased renal function. Second study demonstrated the association of MMP-2 and PAPP-A with proteinuria in patients with CKD. Moreover, serum MMP-2, MMP-9 and PAPP-A levels significantly differed in patients with various nephropathies. EN-RAGE levels are not elevated in patients with CKD, but are related to inflammatory status. PAPP-A, EN-RAGE and HMGB-1 levels are significantly elevated, but sRAGE and PIGF levels are not increased in AKI patients. Whereas PAPP-A correlates with markers of nutrition; PIGF, EN-RAGE and HMGB-1 are related to inflammatory parameters in AKI patients. Taken together, these studies identified the novel biomarkers to be useful in patients with renal disease.

KEY WORDS

acute kidney injury, biomarkers, chronic kidney disease, chronic inflammation, cardiovascular risk, endothelial dysfunction, placental growth factor, pregnancy associated plasma protein A, matrix metalloproteinase 2, matrix metalloproteinase 9, soluble receptor for advanced glycation end products, calcium binding protein S100A12, extracellular newly identified RAGE binding protein, high mobility group box protein-1, haemodialysis, malnutrition, oxidative stress.

ABBREVIATIONS

AAV – anti-neutrophil cytoplasmic antibodies associated vasculitis	CRS– cardiorenal syndrome
ACE – angiotensin-converting-enzyme	Cs – corticosteroids
ACEI – angiotensin converting enzyme inhibitor	CV – cardiovascular
ACR – albumin – creatinine ratio	CVD – cardiovascular diseases
AER – albumin excretion rate	CVR – cardiovascular risk
ADAM-10 – sheddase a disintegrin and metalloprotease	DM – diabetes mellitus
ADMA – asymmetric dimethylarginine	ECM – extracellular matrix
ADOQI – Acute Dialysis Quality Initiative	eGFR – estimated glomerular filtration rate
AGEs – advanced glycation end products	ELISA – enzyme linked immunosorbent assay
AKI – acute kidney injury	EMA – European Medicines Agency
AKIN – acute kidney injury network	EN-RAGE – calcium binding protein S100A12 (extracellular newly identified RAGE binding protein)
ANCA – anti-neutrophil cytoplasmic antibodies	ESRD – end stage renal disease
ANOVA – analysis of variance	F – female
AR – angiotensin II receptor	FABP – fatty acid binding proteins
ARB – angiotensin receptor blockers	FDA – Food and Drug Administration
ATN – acute tubular necrosis	FGF-23 – fibroblast growth factor 23
AUC – area under curve	FSGS – focal segmental glomerular sclerosis
BMI – body mass index	GFR – glomerular filtration rate
BNP –brain natriuretic peptide	GN – glomeronephritis
BUN – blood urea nitrogen	HD – haemodialysis
CAD – coronary artery disease	HDL – high density lipoprotein
CAPD – continuous ambulatory peritoneal dialysis	H-FABP – heart-type fatty acid binding proteins
CHRI – chronic renal insufficiency	HMG – high mobility group
Cis – cyclosporine	HMGB-1 – high mobility group box protein-1
CKD – chronic kidney disease	Hpx – hemopexin
CML – N ϵ -(carboxymethyl)-lysine-protein	HRP – horseradish peroxidase
CPB – cardiopulmonary bypass	ICAM-1 – intercellular adhesion molecule 1
CRP – C reactive protein	IgA – immunoglobulin A

IgAN – immunoglobulin A glomeronephritis
 IGF – insulin like growth factor
 IL – interleukin
 KDOQI – Kidney Dialysis Outcomes Quality Initiative
 KIM – human kidney injury molecular
 LDL – low density lipoprotein
 LN – lupus nephritis
 LPS – lipopolysaccharide
 LV – left ventricular
 M – male
 MAP – mitogen-activated protein
 MCNS – minimal change nephritic syndrome
 MCP-1 – monocyte chemotactic protein-1
 MDRD – modification of diet in renal disease
 MMP-2 – matrix metalloproteinase 2
 MMP-9 – matrix metalloproteinase 9
 MMPs – matrix metalloproteinases
 MN – membranous nephropathy
 NAG – N-acetyl- β -D Glukosaminidase
 NF- κ b – nuclear factor kappa-light-chain-enhancer of activated B cells
 NGAL – neutrophil gelatinase – associated lipocalin
 NO – nitric oxide
 OPN – osteopontin
 PAPP-A – pregnancy associated plasma protein A
 PDGF – platelet derived growth factor
 PlGF – placental growth factor
 RAA – renin angiotensin axis
 RAS – renin angiotensin system
 RAGE – receptor for advanced glycation end products
 RIFLE – Risk, Injury, Failure, Loss, End stage renal disease
 ROC – receiver operating characteristic
 ROS – reactive oxygen species
 RRT – renal replacement therapy
 S100A12 – EN-RAGE, calcium binding protein (extracellular newly identified RAGE binding protein)
 SCr – serum creatinine
 SD – standard deviation
 SE – standard error
 sFlt-1 – soluble fms-like kinase-1, soluble vascular endothelial growth factor receptor
 sRAGE – soluble receptor for advanced glycation end products
 TFEC – S-(1.1.2.2-tetrafluoroethyl)-l-cystein
 TIMPs – tissue inhibitors of matrix metalloproteinases
 TLR – toll like receptor
 TMB – 3,3',5,5'-Tetramethylbenzidine
 TNF- α – tumor necrosis factor α
 TRACE – time resolved amplified cryptate emission
 UTI – urinary tract infection
 VCAM-1 – vascular cell adhesion molecule 1
 VDR – vitamin D receptor
 VEGF – vascular endothelial growth factor
 VEGFR-1
 VEGFR-1, VEGF R1, VEGF R2 - vascular endothelial growth factor receptors

1 INTRODUCTION

1.1 OUTLINE

Given the dramatic expansion in the number of patients being treated for renal disease including patients with chronic kidney disease (CKD) and end stage renal disease (ESRD) and the increasing number of patients with acute kidney injury (AKI), renal medicine becomes an increasingly common problem in clinical medicine [1-3].

Kidney disease predisposes to cardiovascular (CV) risk. Modifying CV risk factors is likely to decrease morbidity and mortality. The multitude of CV risk factors in patients with renal disease increases with age, the stage of kidney disease, and the level of proteinuria. Hypertension, a powerful risk factor, goes along with sodium retention and activation of renin angiotensin system. The mechanisms leading to CV risk (CVR) patients with renal disease include hemodynamically mediated damage, hormonal factors, immune mediate damage and endothelial dysfunction. Atherosclerosis results from an impairment of endothelium, which in turn is associated with albuminuria. Changes in blood-lipid composition and oxidative stress as a consequence of inflammation due to kidney dysfunction also contribute to endothelial dysfunction and subsequent cardiovascular disease (CVD) [4].

Hallmarks of kidney dysfunction are drop of the glomerular filtration rate (GFR), volume expansion, humoral signaling, anaemia, uremic toxins and inflammation.

Biomarkers, defined as signaling events in biological systems, can be conceptualized and defined in three operational classes: exposure, effect or response, and susceptibility [5]. The identification of early and sensitive biomarkers of exposure allows the development of strategies to prevent cell and tissue damage that results in persistent and irreversible injury.

Biomarkers of relevance in the context of renal disease and associated CVD mainly hold the proteins known in either in the field of nephrology or cardiology. The cadre of biomarkers that are feasible for routine use in the care of patients with CKD and AKI and the associated CVR is increasing. Based on these assumptions this thesis assesses the contemporary unmet needs for novel biomarkers in patients with renal disease and the risk for inflammation, oxidative stress, and high cardiovascular risk. Its purpose is to provide an overview of the pathophysiological, biochemical, clinical and analytical characteristics of several biomarkers that have potential clinical utility to identify patients at risk with renal

disease. These biomarkers have demonstrated promise and need to be more thoroughly evaluated before implementation into routine clinical and laboratory practice. Subsequent research part presents the results and conclusions of the original studies of several novel biomarkers in patients with CKD and AKI.

1.2 CHRONIC KIDNEY DISEASE, OXIDATIVE STRESS, ATHEROSCLEROSIS, MICRO-INFLAMMATION AND CARDIOVASCULAR RISK

CKD is defined as abnormalities of kidney structure or function, present for 3 months, with implications for health [6]. CKD is defined as the presence of kidney damage, manifested by markers of kidney damage one or more including albuminuria, urine sediment abnormalities, electrolyte and other abnormalities due to tubular disorders, abnormalities detected by histology, structural abnormalities detected by imaging, history of kidney transplantation, decreased glomerular filtration rate (GFR) $< 60 \text{ ml/min/1.73 m}^2$ [6].

The US NKF-DOQI (National Kidney Federation –Kidney Dialysis Outcomes Quality Initiative) classification of CKD has been first introduced in 2002 and has rapidly been adapted internationally. It is both simple and useful, dividing CKD into 5 stages, according to GFR [7]. In 2012, published in 2013, a new classification was introduced [6, 8]. Table 1 presents the new classification of CKD; severity of CKD is expressed by level of GFR and albuminuria.

CKD is characterized by hypofiltration, or reduced single nephron glomerular filtration rate, secondary to endothelial dysfunction, mesangial cell contraction, and mesangium expansion that reduces the glomerular filtration surface area for filtration (or the ultrafiltration coefficient, K_f). Reduction in glomerular surface area, which is represented by K_r and directly correlates with glomerular filtration rate (GFR) decline, is caused by several pathogenic stimuli, including angiotensin II, hyperglycemia, systemic hypertension, high salt diet, protein overload and inflammatory cytokines [9-16].

These stimuli induce inflammation and oxidative stress in the kidney, which promote GFR loss by at least four mechanisms. Two of these mechanisms, glomerular endothelial dysfunction and mesangial cell contraction are acute, dynamic processes involving dysregulation of GFR. The other two mechanisms, mesangium expansion and fibrosis-mediated nephron loss, induce long-term structural changes in kidney that reduce GFR.

Chronic activation of inflammatory pathways promotes tubulointerstitial disease, which may lead to long-term fibrosis-mediated nephron loss.

TABLE 1 GFR AND ALBUMINURIA CATEGORIES IN THE NEW CLASSIFICATION

Category GFR	GFR, ml/min/1.73 m ²	AER, mg/d	ACR Equivalent	Descriptor
G1	≥ 90	-	-	Normal or high
G2	60-89	-	-	Mildly decreased* †
G3a	45-59	-	-	Mildly to moderately decreased
G3b	30-44	-	-	Moderately to severely decreased
G4	15-29	-	-	Severely decreased
G5	< 15	-	-	Kidney failure
Albuminuria				
A1	-	<30	<30	Normal to mildly increased
A2	-	30-300	30-300	Moderately increased
A3	-	>300	>300	Severely increased ‡

ACR – albumin – creatinine ratio, AER – albumin excretion rate, GFR – glomerular filtration rate

* Relative to young adult level

† In the absence of evidence of kidney damage, neither GFR category G1 nor G2 fulfill the criteria for chronic kidney disease

‡ Including the nephrotic syndrome (AER usually – 2200 mg/d [ACR – 2220 mg/gl]. (according to [6]).

A parallel can be drawn between the pathogenic role of chronic vascular inflammation in the development of hypertension and atherosclerosis and its role in affecting GFR in CKD. Inflammation induced oxidative stress is a known mediator of endothelial dysfunction, smooth muscle tone, and foam cell activation. Chronic vascular inflammation has been shown to promote hypertension, atherosclerosis, cardiac hypertrophy, and other vascular diseases [17-19].

Hypertension results from dynamic changes in the function of otherwise normal cells and can be reversed after relatively short therapeutic interventions, whereas atherosclerosis represents a structural change in the vasculature and requires a longer period of therapeutic intervention to demonstrate effect.

Patients with CKD also have a higher rate of CVD morbidity and mortality than the general population from early stages of the disease, and this rate may increase by 1000-fold in advanced stages of CKD (stages 4-5 and on renal replacement therapy (RRT)) [4]. The heart and kidneys are tightly connected; primarily disorders of one of these organs often result in secondary dysfunction or injury of the other one. Such interactions play a pivotal role in the pathogenesis of a clinical entity called the cardiorenal syndrome (CRS) [20]. The term refers to the complex interaction between the cardiovascular and renal systems in acute and chronic renal diseases. CRS is classified into five subtypes to provide a more concise approach to this condition [21]. CKD is a well-known independent cardiovascular risk factor due to its role in left ventricular (LV) hypertrophy and coronary atherosclerosis pathogenesis [22]. The CVR increases gradually with decreasing renal function [23].

This high rate of morbidity and mortality cannot be explained only by traditional CVR factors such as diabetes, hypertension, smoking, hyperlipidemia, and age. CKD patients have additional non-traditional risk factors directly related to their disease including uremia, hyperhomocysteinaemia, altered calcium and phosphorus metabolism, malnutrition, increased oxidative stress and chronic microinflammation [24].

Furthermore, among nontraditional risk factors, the chronic micro-inflammation state present in uremia currently has a very significant role in the development of endothelial damage in CKD patients. This is shown by the large number of studies published in the literature reporting an association between the micro-inflammation state and development of endothelial dysfunction from the early stages of CKD. It is known that endothelial dysfunction is the first step for subsequent development of atherosclerosis, which can help us to explain in part the high rate of CVD in this group of patients [25-28].

The vascular endothelium regulates vascular tone by releasing vasoactive substances such as nitric oxide (NO). Therefore, the deficiency in NO that CKD patients are known to have from the early stages of the disease [29] will lead to signs of endothelial dysfunction from impaired endothelium dependent vasodilation, thus promoting the development of atherosclerosis and subsequent appearance of cardiovascular events.

One of the mechanisms that has been proposed to cause the endothelial damage is the production of reactive oxygen species (ROS) in areas of inflammation [30] and their release causing an imbalance between pro-inflammatory and anti-inflammatory mechanisms, which is known to occur in uremic patients [31]. If the number of ROS is high and if release of these ROS persists over time, the defense mechanisms of endothelial cell may be insufficient and

endothelial damage is produced with subsequent development of atherosclerosis, leading to the reduction of plasma NO levels [29, 32].

The increase in asymmetric dimethylarginine (ADMA), which is a competitive inhibitor of endothelial NO synthetase, is another mechanism in the reduction of plasma NO levels caused by reduced renal clearance of ADMA in CKD setting leading to the dysfunction of the endothelium dependent vasodilation [33]. High levels of ADMA were reported in CKD and were associated with higher intima-media thickness and cardiovascular events in CKD [34].

The mechanisms underlying the associations between endothelial damage, oxidative stress and inflammation in CKD patients are not fully understood but are likely to include increased production and reduced excretion of proinflammatory cytokines and their soluble receptors [34-38], activation of immune system in CKD [39, 40] and the enhanced activation of renin angiotensin system (RAS) [38, 41, 42].

In addition, both hypertension and disorders in lipoprotein composition [43-45] and metabolism [46] have been recognized consequences of CKD, laying the foundation of vascular disease in patients with renal disease regardless of aetiology.

Moreover, oxidative stress and impaired antioxidant capacity intensify with progression of CKD [47, 48] and production of reactive oxygen species and oxidative stress result in activation of the transcription factor nuclear factor κ B (NF κ B). NF κ B is a thoroughly studied actor in innate immunity, stress response, cell survival and development, moreover the major transcriptional mediator of the inflammatory response [49, 50].

Activated NF κ B is present in the kidneys of patients with diabetic nephropathy but is undetectable in normal healthy kidneys [51]. It has been demonstrated that in experimental proteinuric nephropaties, proteinuria increases NF- κ B activity, which activates genes encoding pro-inflammatory and fibrogenic molecules involved renal injury [52, 53]. Chronic activation of these pathways leads to interstitial inflammation and fibrosis [54-56].

To respond to oxidative and electrophilic stimuli, organisms have developed elaborate cytoprotective pathways that are directly regulated by the transcription factor nuclear factor erythroid-2-related factor 2 (Nrf2). Its central role in the maintenance of redox balance and protection against oxidative stress is now well recognized. Unfortunately, long-term inflammatory signaling can result in decreased Nrf2 activity, decreased antioxidant capacity, chronic inflammation and disease progression [57-59]. In animals with CKD, oxidative stress

and inflammation are associated with CKD, oxidative stress and inflammation are associated with impaired Nrf2 activity [60-62].

Disorders of altered calcium phosphate metabolism including progressing vascular calcification is a common complication in CKD due in part to disturbed mineral metabolism and the therapies used to control it [63], but also due to a complex, active process of osteogenesis in vascular smooth muscle cells [64, 65]. Both vascular stiffness and vascular calcification have been found to occur in patients with earlier stages CKD [66, 67]. Progressive uremia and dialysis vintage have been reported to worsen vascular and valvular calcifications [66].

An emerging science around vitamin D receptor (VDR) activation may pertain to mitigate CKD – related calcification. The VDR is expressed widely in organ and cellular systems in the body. Impairment of VDR activation has been implicated in the dysfunction of vascular smooth muscle and endothelium, and in accelerated atherosclerosis, calcification and cardiac hypertrophy [68, 69]. Pre-clinical research is ongoing into mechanisms by which vitamin D may exert protective effects on inflammatory cytokines, glycemic control, the renin-angiotensin-aldosterone system, and directly on the vasculature [70].

Thus vitamin D agents may have pro- and anti-atherosclerotic properties. Calcitriol appears to influence the gene expression of vascular endothelial growth factor (VEGF), one of the early steps of atherosclerosis development [71]. Emerging science supports that VDR activation may favorably affect aortic injury in atherosclerosis [71] and progress of calcification [72] and thus may have a protective role to play in future therapies that reduce CVD morbidity in patients with CKD [73].

Moreover, therapeutic interventions that suppress pathogenic inflammation and reduce oxidative stress in the kidney have the potential to address both the acute/dynamic and long-term/structural contributors to GFR decline. Since endothelial dysfunction and mesangial cell contraction result from dynamic biochemical and physiological processes in otherwise normal cells, these conditions may be reversible in a relatively short period of time.

Hence, their impact on GFR would be observed soon after an intervention and would likely fade soon after withdrawal of the intervention. By contrast, inhibition of inflammatory processes may be able to arrest the progression of structural changes, such as mesangium expansion and fibrosis-mediated nephron loss that impair GFR and may or may not reverse these conditions. If the anti-inflammatory effects have any beneficial impact, it would likely manifest over a long period of time, but would be presumably be more durable and may

persist beyond the withdrawal of the interventions. Thus, reversal of inflammatory processes should manifest as an increase of GFR, due to multiple processes, some of which act acutely while others act chronically.

In summary, it is evident that the vascular endothelium is a metabolically active organ with multiple functions, including protection against development of atherosclerosis and hypertension. The endothelial damage or dysfunction has been detected in patients with renal impairment from early stages of the disease. Therefore, endothelial damage, oxidative stress, inflammation, disorders of calcium phosphate metabolism in conjunction with progression of CKD and interaction with alteration in lipoprotein metabolism do synergistically augment CVR.

Chronic inflammation is very common in patients with CKD. The high burden of CV disease in this patient population and the failure of several traditional therapeutic interventions have led to an increased focus of nontraditional risk factors, of which chronic inflammation appears to be particularly important. There is currently no single best test to assess inflammation in CKD for diagnostic purposes. Therefore a working knowledge of promising biomarkers to assess inflammation in patients with CKD is important to improve outcomes in this patient population and propose therapeutic strategies to reduce the levels of inflammatory markers.

1.3 ACUTE KIDNEY INJURY

The term “acute renal failure” was first introduced in 1951 by Homer Smith with reference to renal failure related to traumatic injury [74]. In spite of its popularity, the term has suffered from a lack of clear definition which limited discussion in the area and has complicated comparisons of epidemiological and therapeutic studies. Generally, the definitions have been based on absolute or relative concentration or changes in levels of serum creatinine.

The term “acute kidney injury” (AKI) was first proposed in 2004, by Acute Dialysis Quality Initiative (ADOQI) and experts from other premier nephrology and critical care associations [75]. The newer term reflects the fact that a rise in serum creatinine does not necessarily mean failure of the kidneys, but a dysfunction, which may or may not lead to failure. ADOQI suggested a graded definition called RIFLE criteria (Risk, Injury and Failure) based on either serum creatinine concentration, GFR or urine output and two levels of

outcome (Loss and End stage renal disease [ESRD]) based on the need for RRT and the time period [76] Fig. 1.

In 2007 the Acute Kidney Injury Network (AKIN) suggested a modified set of criteria based on RIFLE approach [77]. AKIN proposed three separate stages for AKI which correspond to the RIFLE criteria: Stage 1 (Risk), Stage 2 (Injury), and Stage 3 (Failure). RIFLE levels Loss and Failure are considered outcome rather than stages. AKIN has defined AKI as: An abrupt (within 48 hours) reduction in kidney function – a rise in serum creatinine by ≥ 0.3 mg/dL (26.52 $\mu\text{mol/L}$), a percentage increase in serum creatinine $\geq 50\%$ from baseline, or documented oliguria of < 0.5 mL/kg/hour for more than 6 hours [78].

Until recently, studies of AKI have focused on the epidemiology and management of AKI during the index hospitalization. However, AKI is now recognized as a disease with long-term sequelae, including increased risk of death and CKD progression [79-82]. The mechanisms by which AKI is linked to adverse long-term outcomes are intensively studied.

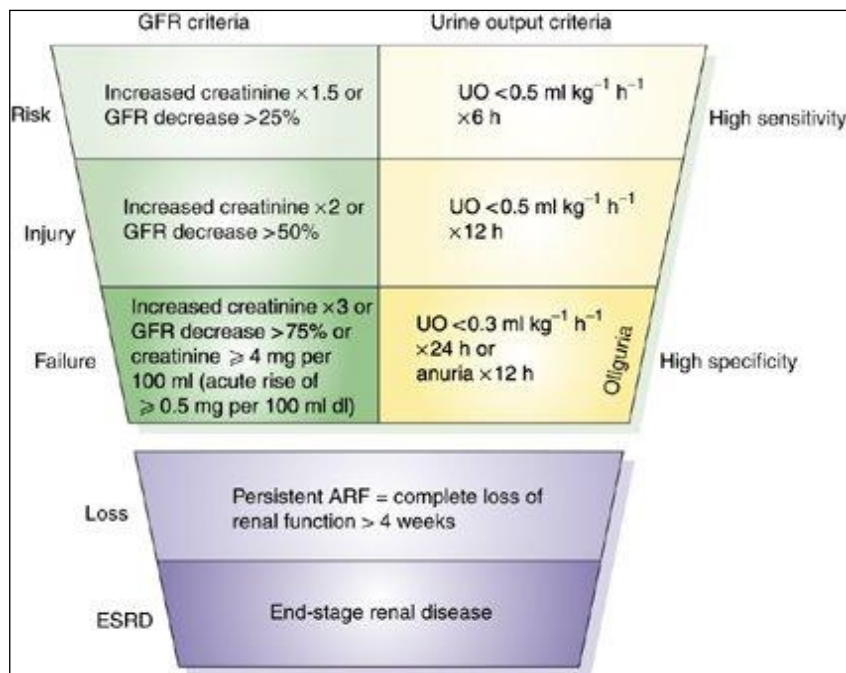

FIG. 1 AKI CRITERIA; ACCORDING TO [83].

A major insight into the pathogenesis of AKI was the recognition that the initial ischemic insult elicits maladaptive responses that exacerbate the injury [84]. In other words, the ultimate extent of injury is not inevitably determined by the initial insult but also by ensuing maladaptive response. These maladaptive responses (Table 2) include inappropriate intrarenal hemodynamics, altered mitochondrial and other metabolic functions [85-87],

endothelial dysfunction [88, 89], and tubular obstruction and back-leak [90]. In addition there is a maladaptive inflammatory response [91-94].

TABLE 2 MALADAPTIVE RESPONSES THAT EXACERBATE ISCHEMIC ACUTE KIDNEY INJURY

Maladaptive renal hemodynamics
Endothelial dysfunction
Maladaptive mitochondrial and other metabolic responses
Production of excessive reactive oxygen species
Tubular obstruction and back-leak
Maladaptive inflammation

The following hypothesis supports the mechanism of ischemic AKI: ischemia results in ROS production, which stimulates TLR4 expression on endothelial cells; at 4 hours of reperfusion, tubular injury results in the release of HMGB-1; HMGB-1 interacts with endothelial TLR4 and activates endothelial cells to express adhesion molecules that allow leukocyte infiltration and the maladaptive inflammation that exacerbates ischemic AKI [95-97].

Taken together, TLR4 expression is differentially regulated in the different cell types within the kidney (i.e., endothelial, leukocytes, and tubular epithelial cells) and occurs at different time points following reperfusion. Regardless of the cell type involved, TLR4 activation by HMGB-1 appears to serve as proinflammatory role in the early stages of ischemia-reperfusion injury in ischemic AKI.

It is feasible that changes commonly found in CKD patients – anaemia, acid/base dysregulation, malnutrition, microinflammation, altered mineral metabolism – likely occur in AKI patients, and as in CKD patients, may be responsible for some these adverse long-term sequelae.

In addition, there is a close association between renal and cardiac function in both acute and chronic kidney diseases [98, 99]. First type of cardio-renal syndrome includes acute worsening of heart function leading to kidney injury and/or dysfunction. Patients with chronic abnormalities in heart function leading to kidney injury and /or dysfunction fall into cardio-renal syndrome of second type. Third type was defined as acute worsening of kidney function leading to heart injury and/or dysfunction. Chronic reno-cardiac syndrome (fourth type) includes CKD leading to heart injury, disease, and/or dysfunction. And the last fifth type

comprises patients with secondary cardio-renal syndrome due to systemic conditions e.g. sepsis, systemic lupus erythematosus, diabetes mellitus, amyloidosis, or other chronic inflammatory conditions, leading to simultaneous injury/or dysfunction of heart and kidney [21, 100].

AKI reflects the entire spectrum of acute renal failure, recognizing that an acute decline in kidney function is often secondary to an injury that causes functional or structural changes in the kidneys. Currently it does not exist a specific therapy for AKI in all cases; early detection of AKI seems at some point without real consequence because of the general lack of promising measures to halt its progression. Early detection might lead to a rethinking in order to implement potentially novel and effective therapies, thereby preventing the onset of severe AKI and significantly improving the renal and overall prognosis. Therefore, a better understanding of the key players in AKI is needed to allow interventions which would shorten the course of AKI, reduce distant organ injury in AKI and improve survival.

1.4 OVERVIEW OF NOVEL BIOMARKERS

An ideal biomarker in renal disease should have the following characteristics: 1) be easily and reliably measured in a noninvasive or minimally invasive manner; 2) be stable; 3) be rapidly and reliably measurable at bedside; 4) be inexpensive to measure; 5) be able to detect CKD or AKI (early in the course) and 6) be predictive in its ability to forecast the course of renal disease and potentially the future implications of renal disease; 7) be useful to identify patients with renal disease and monitor inflammatory, nutritional and cardiovascular risk.

The purpose of this chapter is to provide an overview of the biochemistry, pathophysiology and clinical and analytical characteristics of several biomarkers that may have potential clinical utility to identify patients with renal disease.

These biomarkers (placental growth factor, pregnancy associated plasma protein A, matrix metalloproteinases with special attention to matrix metalloproteinase-2 and matrix metalloproteinase-9, soluble receptor for advanced glycation end products, calcium binding proteins S100A12, high mobility group box protein-1) have demonstrated promise and need to be more thoroughly evaluated for implementation into clinical and laboratory practice in renal medicine.

The following part provides potential perspectives of other emerging biomarkers in CKD and AKI.

1.4.1 PLACENTAL GROWTH FACTOR

Placental growth factor (PlGF) is one of a family of platelet derived proteins that function as potent chemoattractants for monocytes and are involved in the regulation of vascular endothelial growth. PlGF is a 50-kDa heterodimer consisting of 149 amino acids and has high homology with vascular endothelial growth factor (VEGF) [101]. PlGF is also related, albeit distantly, to the platelet derived growth factor (PDGF) family of growth factors [102].

The PlGF sequence predicts a 149 amino acid mature protein with a 21 amino acid signal sequence a centrally located PDGF-like domain with 8 conserved cysteine residues that form a cysteine knot structure [101]. PlGF shares approximately 42% amino acid sequence identity with VEGF, and the two share structural similarity [102]. Although PlGF does not share the proangiogenic receptor VEGF R2 with VEGF, both bind VEGF R1 (soluble and transmembrane forms), Neuropilin-1, and Neuropilin-2 [103-107]. VEGF and PlGF appear to have different effects on VEGF R1 activity and, subsequently, affect expression of different downstream genes [108].

PlGF exists in at least four alternatively spliced forms: PlGF-1, PlGF-2, PlGF-3 and PlGF-4 [102, 109-111]. Notable differences between these forms include the insertion of a heparin-binding domain in PlGF-2 and PlGF-4 that might result in increased association with cell membrane or altered affinities for PlGF receptors [112]]. As the name implies, PlGF was first identified in human placenta, and indeed, is expressed prominently in placenta under normal conditions [101, 102, 109, 113]. Other tissues expressing PlGF include the heart, thyroid gland, lung, bone marrow, and skeletal muscle [114].

The biological functions of PlGF are intensively studied. It is known that VEGF is required in hematopoietic stem cells as an intracrine survival factor. PlGF acts via two distinct mechanisms, either directly by recruiting VEGFR-1-expressing cells, or by inducing MMP-9 expression in bone-marrow stromal cells. Released MMP-9 cleaves the cell surface of the soluble Kit ligand and the soluble ligand contributes to the recruitment and mobilization of the hematopoietic stem cells. Hematopoietic stem cells and endothelial progenitor cells enter the circulation and contribute to stimulation of angiogenesis and arteriogenesis as well as

hematopoietic recovery after myelosuppression: processes enhanced by PlGF. On the other hand, inhibition of VEGFR-1– ligand signaling using anti-VEGFR-1 inhibits stem-cell recruitment and mobilization as well as inflammatory cell invasion into tissues Fig. 2 [115].

The mechanisms underlying PlGF effects on the vascular endothelia continue to be elucidated. The activity could come from the direct activation of VEGF R1 by PlGF [116]. However, only the extracellular domain appears to be necessary, suggesting the phenotype may not be due to intracellular signaling [117]. PlGF can synergistically enhance VEGF induced angiogenesis and vascular permeability [105, 117-119].

PlGF is secreted as a homodimer, but may also form heterodimers with VEGF [120] . Although the activity of PlGF/VEGF heterodimer in angiogenesis is unclear, it may induce an active VEGF receptor heterodimer consisting of VEGF R1 and VEGF R2 [108, 111].

Monocytes/macrophages have also been implicated in neovascularization. PlGF stimulates monocyte activation and chemotaxis in vitro, and a monocyte-mediated mechanism has been implicated in PlGF-induced arteriogenesis in vivo [121, 122].

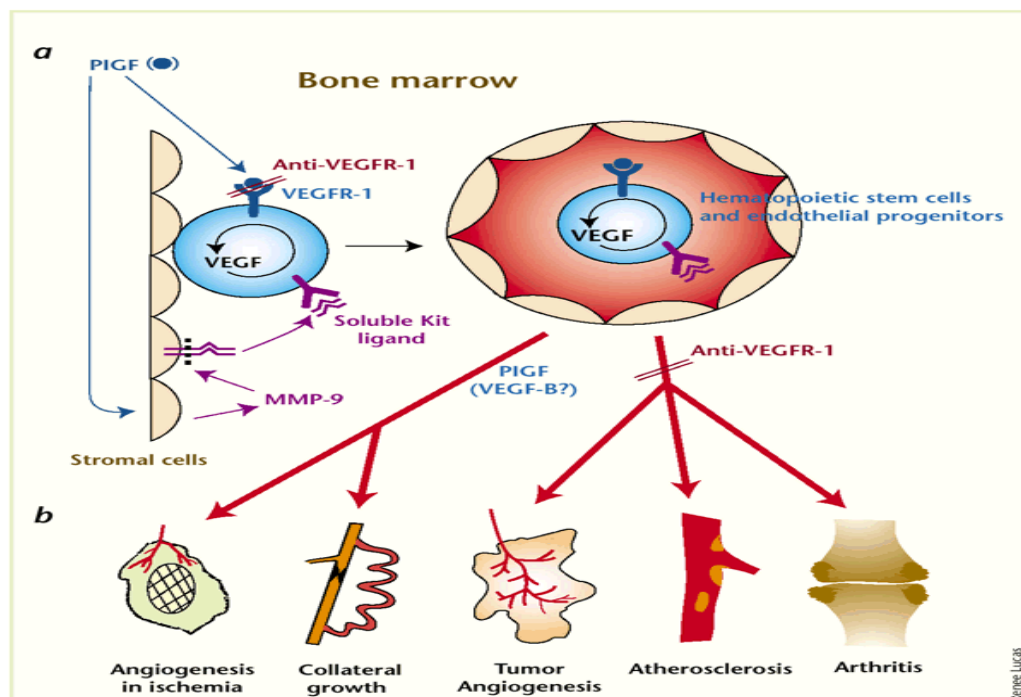

FIG. 2 STEM-CELL RECRUITMENT AND MOBILIZATION IN THE BONE MARROW BY PLGF, AND SITES OF INHIBITION BY VEGFR-1 BLOCKING ANTIBODIES (REPRINTED BY PERMISSSION FROM MACMILLIAN PUBLISHERS LTD: NATURE MEDICINE 8, 775-777 (2002) [115]

In addition PIGF appear to be primarily involved in an initiation of the inflammatory process, which includes the recruitment of circulating macrophages into atherosclerotic lesions, stimulation of smooth muscle cell growth, and up-regulation of both tumor necrosis factor α (TNF- α) and monocyte chemotactic protein 1 (MCP-1) by macrophages [118]. PIGF also reportedly activates stem cells from a quiescent to proliferative state and in this way stimulate haematopoiesis in the bone marrow of mice [112].

Elevated levels of PIGF expression in placenta, and more specifically in the villous cytotrophoblasts and the syncytiotrophoblasts, may indicate a role for PIGF in placenta formation [114, 123, 124]. In addition, PIGF can protect trophoblasts from growth factor withdrawal – induced apoptosis [116].

Levels of PIGF do fluctuate during human pregnancy. Circulating levels of PIGF increase during the first 29-32 weeks of pregnancy and decrease thereafter [125]. PIGF has also been used as predictor of the common pregnancy-associated hypertensive disorder preeclampsia. Plasma, serum, and urine PIGF levels decrease significantly in women with preeclampsia, and/or those who subsequently develop the disorder [114, 125-128].

Increased PIGF levels have been described in several conditions including cancer [129-131], cutaneous wound and bone fracture healing [119, 132-134], and sickle cell disease [135].

PIGF was recently shown to be up-regulated in early and advanced atherosclerotic lesions [136]. PIGF stimulates vascular smooth muscle growth, recruits macrophages into atherosclerotic lesions, up-regulates production of TNF- α and MCP-1 by macrophages and stimulates pathological angiogenesis [102, 136]. Inhibition of PIGF effects by blocking of its receptor, Fms-like tyrosine kinase, in an animal model suppressed both atherosclerotic plaque growth and vulnerability via inhibition of inflammatory cell infiltration [136]. These data suggest that PIGF may act as a primary instigator of atherosclerotic lesions.

In summary, PIGF appears to be have great potential as an independent biomarker for plaque disruption, ischemia, and thrombosis. Since accelerated atherosclerosis is one of the consequential complications of CKD and haemodialysis [137], PIGF might be an early marker of vascular inflammation possibly related to CV outcome also in patients with renal disease.

1.4.2 PREGNANCY ASSOCIATED PLASMA PROTEIN A

Pregnancy associated plasma protein A (PAPP-A) is a high molecular mass (~200 kDa) glycoprotein synthesized by the syncytiotrophoblast and is typically measured during pregnancy for screening of Down syndrome [138]. PAPP-A is a zinc-binding matrix metalloproteinase belonging to the metzincin superfamily of metalloproteinases. It is composed of five domains: the N-terminal laminin like domain, the metzincin proteolytic domain which is responsible for insulin-like growth factor binding proteins cleavage, a central domain of unknown identity, and a domain defined by five complement control protein modules which is responsible for binding to the cells surface and C terminal domain [139]. PAPP-A exists as homodimer of 400 kDa which proteolytically active and as a proteolytically inactive PAPP-A/proMBP (major basic protein) heterotetrameric complex of 500 kDa [139]. PAPP-A has the ability to cleave itself resulting in fragments of 150 kDa and 50kDa [140].

The enzymatic activity of PAPP-A is directed towards insulin-like growth factor (IGF) binding proteins 2, 4 and 5 and leads to the release of bound IGF [141, 142] Fig 3. [143].

PAPP-A is mainly produced by the syncytiotrophoblast during pregnancy but also by fibroblasts, osteoblasts, endothelial and vascular smooth muscle cells in both men and women. It is expressed also in the endometrium, testis, kidney, bone, colon, and various adult and fetal tissues [144, 145].

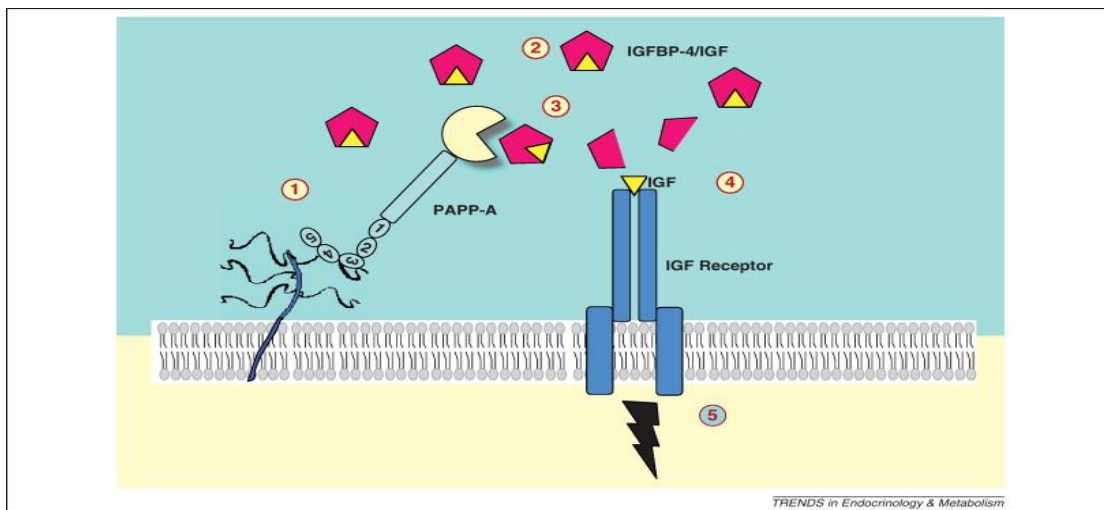

FIG. 3 LOCAL CONTROL OF IGF SIGNALING BY CELL-ASSOCIATED PAPP-A. (REPRINTED BY PERMISSION FROM ELSEVIER LTD: TRENDS IN ENDOCRINOLOGY AND METABOLISM 23, 242-249 (2012) [143].

PAPP-A is widely used to exclude foetal trisomy in the first trimester of gestation. PAPP-A was also found to be abundantly expressed in eroded and ruptured vascular plaques, but is only minimally expressed in stable plaques [146]. In pregnancy, PAPP-A circulates in a heterotetrameric complex consisting of 2 PAPP-A subunits covalently bound with 2 subunits of the preform of eosinophil major basic protein (proMBP), its endogenous inhibitor [147]. However, PAPP-A present in human fibroblasts and released during atherosclerotic plaque disruption seems to be a homodimeric active form, uncomplexed with the inhibitor proMBP [142]. In vitro studies showed that IGF may induce macrophage activation, chemotaxis, low-density lipoprotein (LDL) cholesterol uptake by macrophages and release of proinflammatory cytokines, thus suggesting a proatherogenic action of IGF-1 [148, 149] Fig. 4 [143].

The presence of PAPP-A in unstable plaques have been observed in patients with acute coronary syndromes [146]. Subsequently it was reported that PAPP-A levels sensitively reflect changes in renal function [150] and could be a prognostic marker in dialysis patients [151, 152].

In summary, additional investigations will be necessary for better understanding of PAPP-A as an independent biomarker for CV, renal and overall risk in patients with renal disease; specifically, possible association with endothelial dysfunction linking CV disease and renal disease.

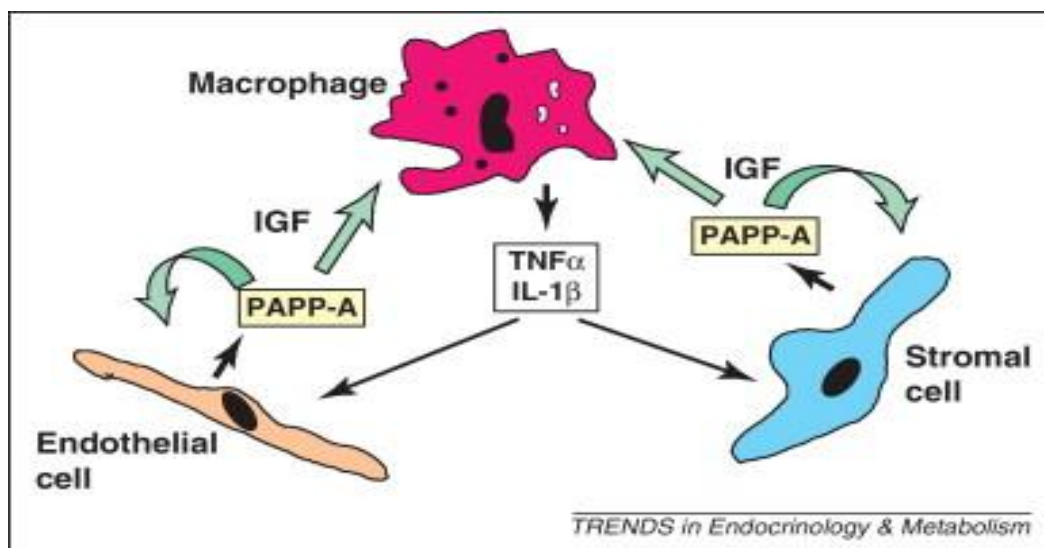

FIG. 4 PAPP-A INDUCED MACROPHAGE ACTIVATION; (REPRINTED BY PERMISSION FROM ELSEVIER LTD: TRENDS IN ENDOCRINOLOGY AND METABOLISM 23, 242-249 (2012) [143].

1.4.3 MATRIX METALLOPROTEINASES, MATRIX METALLOPROTEINASE 2, MATRIX METALLOPROTEINASE 9

Matrix metalloproteinases (MMPs), also called matrixins, are zinc-dependent endopeptidases; other family members are adamalysins, serralysins, and astacins. The MMPs belong to a larger family of proteases known as metzincin superfamily [153].

Humans have 24 matrixin genes including duplicated MMP-23 genes, thus there are 23 MMPs in humans. The activities of most matrixins are very low or negligible in the normal steady-state tissues, but expression is transcriptionally controlled by inflammatory cytokines, growth factors, hormones, cell-cell and cell-matrix interaction [154].

Matrixin activities are also regulated by activation of the precursor zymogenes and inhibition by endogenous inhibitors, tissue inhibitors of metalloproteinases (TIMPs). Thus, the balance between MMPs and TIMPs are critical for eventual ECM remodeling.

The main function of matrixins has been considered to be the degradation and removal of ECM molecules from the tissue. However, it has been increasingly recognized that breakdown of ECM molecules or cell surface molecules alters cell-matrix and cell-cell interactions and the release of growth factors that are bound to ECM makes them available for cell receptors. In addition, a number of non-ECM molecules are also potential substrates of MMPs. MMPs actions that may affect cell migration, differentiation, growth, inflammatory processes neovascularization, apoptosis, etc.

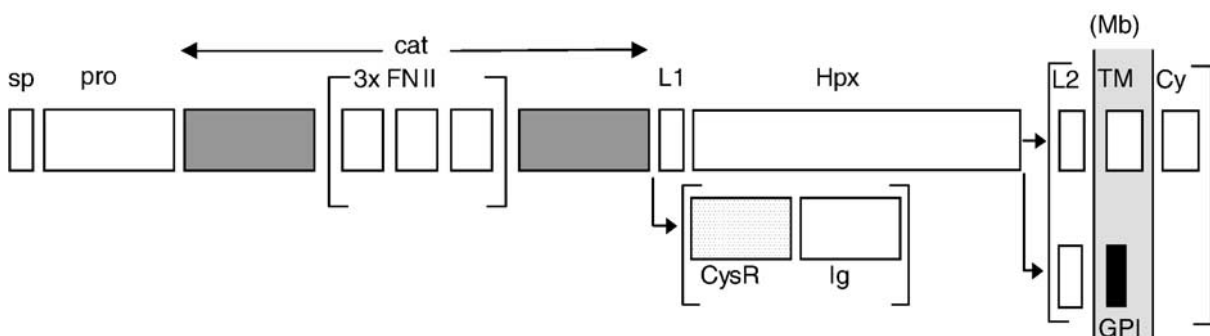

FIG. 5 DOMAIN STRUCTURES OF THE MMP FAMILY [155].

sp, signal sequence; pro, pro-domain; cat, catalytic domain, FNII, fibronectin type II motif; L1, linker 1; Hpx, hemopexin domain; L2, linker 2; Mb, plasma membrane; TM, transmembrane domain; Cy, cytoplasmic tail; CysR, cysteine rich; Ig, immunoglobulin domain; GPI, glycosylphosphatidylinositol anchor according to [155]).

The MMPs have a common domain structure and consists of a propeptide of about 80 aminoacids, a catalytic metalloproteinase domain of about 170 amino acids, a link flexible peptide of variable lengths (also called the ‘hinge region’ and a hemopexin (Hpx) domain of about 200 amino acids) Fig. 5 [155] .

Two gelatinases, gelatinase A (MMP-2) and gelatinase B (MMP-9), have three repeats of fibronectin type II motif in the metalloproteinase domain. The zinc binding motif HEXXHXXGXXH in the catalytic domain, and the ‘cystein switch’ motif PRCGXPD in the propeptide are common structural signatures, where three histidines in the zinc binding motif coordinate and the cysteine in the propeptide coordinate with the catalytic zinc ion and are common structural signatures. This Cys-Zn²⁺ coordination keeps proMMPs inactive by preventing a water molecule essential for catalysis from binding to zinc atom. The catalytic domain also contains a conservative methionine, forming a ‘Met-turn’ eight residues after the zinc binding motif, which forms a base to support the structure around catalytic zinc [156].

Based on domain organization and substrate preference, MMPs are grouped into collagenases, gelatinases, stromelysins, matrilysins, membrane-type (MT)-MMPs and others.

MMP-2 have collagenolytic activity, but is classified into other subgroup because of it domain composition. Gelatinases (MMP-2 and MMP-9) readily digest gelatin with help of their three fibronectin type II repeats that binds to gelatin/collagen. They also digest a number of ECM molecules including type IV, V, and XI collagens, laminin, aggrecan core protein, etc. MMP-2 but not MMP-9 digests collagens I, II, and III in a similar manner to collagenases [157, 158].

The collagenolytic activity of MMP-2 is much weaker than MMP-1 in solution, but because proMMP-2 is recruited to the cell surface and activated by the membrane-bound MT-MMPs, it may express reasonable collagenolytic activity on or near the cell surface.

MMPs are synthesized as pre-proenzymes. The signal peptide is removed during translation and proMMPs are generated. Activation of these zymogens is therefore an important regulatory step of MMP activity.

MMP activities are regulated by two major types of endogenous inhibitors: α_2 -macroglobulin and TIMPs. Human α_2 -macroglobulin is a plasma glycoprotein of 725 kDa consisting of four identical subunits of 180 kDa. It inhibits most proteinases by entrapping the proteinase within the macroglobulin and the complex is rapidly cleared by the receptor (low density lipoprotein receptor-related protein-1) – mediated endocytosis [159].

MMP activities in the fluid phase are primarily regulated by α_2 -macroglobulin and related proteins.

TIMPs, consisting of 184 – 194 amino acids, are inhibitors of MMPs. They are subdivided into an N-terminal and C-terminal domain. Each domain contains three conserved disulphide bonds and the N terminal domain folds as an independent unit with MMP inhibitory activity. TIMPs inhibit all MMPs tested so far [155].

Taken together, a wealth of knowledge has been accumulated to show that metalloproteinases play many roles in both biological and pathological processes. Biochemical studies of MMPs have characterized their functions and the 3D structures have provided the molecular basis for our understanding of how these multi-domain proteinases function and interact with ECM molecules and inhibitors. Structural and functional studies have also provided us with clues as to how to manipulate the enzymatic activities.

1.4.3.1 *MATRIX METALLOPROTEINASE 2 (MMP-2)*

Matrix metalloproteinase-2 (MMP-2) is a metalloproteinase which can remodel ECM proteins, leading to a change in the balance between ECM synthesis and degradation, which may result in an accumulation of ECM molecules [160]. MMP-2 is zinc-dependent and is known as gelatinase A. MMP-2 degrades ECM proteins in the kidney and vessels including fibronectin, laminin and collagens [161]. Various forms of glomerular disease are characterized by a profound imbalance between matrix synthesis and degradation. While in the scarring process the balance is shifted toward increased synthesis, excess degradative activity promotes glomerular destruction in inflammatory diseases [162, 163].

Recent studies have shown that MMP-2 is involved in the development and progression of CKD and CVD inducing tissue remodeling via structural alterations in the glomerular and tubular areas; MMP-2 also play roles in blood vessel injury [161, 164-166].

Plasma MMP-2 levels have been shown to be positively correlated with serum creatinine in CKD patients [167, 168]. Moreover, it was suggested that serum levels of MMP-2 are one of the independent correlates of proteinuria and could be associated with intima media thickness and atherosclerotic plaque in patients with CKD [169].

In summary, previous studies suggest that MMP-2 may be of value in evaluating patients with renal disease. However, many important aspects of MMPs and their role in renal biology and determinants of their levels still remain unclear.

1.4.3.2 *MATRIX METALLOPROTEINASE 9 (MMP-9)*

Matrix metalloproteinase-9 (MMP-9) is a zinc-dependent metalloproteinase and is also known as gelatinase B. Gelatinases have three repeats of the fibronectin-binding domain that allow them to bind to gelatine, collagen, and laminin. MMP-9 has significantly more specificity towards types IV and V collagen [161]. Activation of proMMP-9 to the active moiety can occur as a result of exposure to NO or via proteolytic activation. MMP-9 can generate angiostatin via an interaction with plasminogen, increase its affinity for collagen, interact with adhesion molecule-1, and be antiinflammatory by processing interleukin (IL)-1 β from its precursor and by reducing interleukin (IL)-2 response [155]. TIMPs regulate the effect of MMP-9 and can have a variety of independent biological effects on inflammation and angiogenesis, which may have important consequences for renal structure and function [155].

It was suggested that the increased concentrations of MMP-9 were related to inflammation in atherosclerotic plaques, which in aggregate might be related to the extent of coronary artery disease (CAD) [170]. An identification of renal disease progression and its associated CV risk has become increasingly important.

In summary, given the importance of MMPs, especially MMP-9 to the pathological glomerular, tubulointerstitial and vascular remodeling associated with many renal diseases [163, 171, 172], and the increased cardiovascular risk of patients with renal impairment [137], serum MMP-9 measurement may function as a biochemical biomarker of connective tissue metabolism in patients with renal disease. Additional studies are needed to evolve the clinical evidence of MMP-9 and support the intended claims.

1.4.4 *SOLUBLE RECEPTOR FOR ADVANCED GLYCATION END PRODUCTS (SRAGE)*

The receptor for advanced glycation end products (RAGE) has emerged as a central regulator for vascular inflammation and subsequent atherosclerosis [173, 174]. In addition RAGE and its ligands are intimately involved in the pathology of a wide range of diseases that share common features such as enhanced oxidative stress, immune/inflammatory responses, and altered cell functions.

RAGE consists of an extracellular region containing the ligand-binding domain, a single hydrophobic transmembrane α -helix, and a short cytosolic tail, which is essential for RAGE signaling [175].

Ligand engagement of RAGE triggers cell-specific signaling, resulting in enhanced generation of reactive oxygen species (ROS), and in the activation of the transcription factor NF- κ B [176]. This leads to sustained up-regulation of pro-inflammatory mediators, adhesion molecules and to dysfunctional cell phenotype [176, 177].

As a multiligand receptor expressed on the cell surface, it could bind various kind of ligands such as members of S100/calgranulins family of proinflammatory molecules, high-mobility group box-1 protein (HMGB-1), β -sheet fibrils, amyloid- β peptide, β_2 -integrin Mac-1 [178]. As well as advance glycation end products (AGEs) [174].

The interaction between RAGE and its ligands result in pro-inflammatory gene activation, thereby creating a causative effect in a wide range of disease, including diabetes mellitus, atherothrombosis, immune/inflammatory conditions, ageing, cancer, and neurodegeneration [179].

Particularly in patients with decreased renal function, RAGE accumulates and exists in several variants [180, 181]. Soluble RAGE (sRAGE), one of them, is a circulating form of RAGE. The mechanisms of sRAGE generation include the ectodomain shedding the membrane-associate receptor, and a RAGE isoform lacking the C-terminal (transmembrane) domain, and in humans it results from alternative splicing of RAGE mRNA [179, 182].

The first process seems to be mediated, at least in part, by several membrane-associated proteases, including the sheddase A Disintegrin And Metalloprotease (ADAM-10), and the matrix metalloproteinase-9 (MMP-9) [183-185]. The second one consists in the expression of a soluble splice-isoform, denominated endogenous secretory (es)RAGE, which is characterized by a specific C-terminal 16-amino acid sequence [186].

sRAGE may act a decoy receptor by competitively inhibiting the binding of RAGE ligands to RAGE, accordingly attenuating the downstream inflammatory responses [181, 187]. Circulating sRAGE levels may inversely reflect RAGE activity, thus providing a useful biomarker of RAGE-mediated pathogenesis [179, 188].

In summary, these interesting observations suggest that circulating sRAGE monitoring may function as a biomarker in several diseases including diseases of kidney and as an indicator of subclinical inflammation and associate atherosclerosis. Additional research is needed to fully evaluate the true potential of this biomarker.

1.4.5 EXTRACELLULAR NEWLY IDENTIFIED RAGE BINDING PROTEIN (EN-RAGE) OR THE CALCIUM BINDING PROTEIN S100A12

Calgranulin C, calcium binding protein S100A12, also known as extracellular newly identified RAGE binding protein (EN-RAGE), is a natural pro-inflammatory ligand for RAGE.

The primary structure of human S100A12 consists of 91 amino acids with molecular mass of 10.4 kD, has two EF-hands and a predicted C-terminal zinc-binding site (His-X_{aa}-X_{aa}-X_{aa}-His) [189]. The EF-hand structural motif consists of a loop flanked by α -helices (helix-loop-helix), which together form a single EF-hand calcium binding site [190].

Human S100A12 shows highest homologies with S100A9 (46%) and to S100A8 (40%). The human S100A12 gene, localized within S100 gene cluster on chromosome 1q21 between S100A8 and S100A9 genes, is composed of 3 exons which are divided by 2 introns. Unlike protein S100A8 and S100A9, homologs with protein S100A12 have been only identifies in some species. There is evidence that chromosomal rearrangements during rodent evolution damaged the murine S100A12 gene, indicating the absence of the protein in mice [191].

The occurrence of human S100A12 in the cytoplasm of granulocytes resembles the distribution pattern of S100A8/S100A9, with the difference being that it is less abundant [192, 193]. In the presence of calcium, S100A12 forms homodimers, but there is no complex formation with S100A8 or S100A9 [194]. Thus, S100A12 acts individually during calcium – dependent signaling, independent of S100A8/S100A9 [195].

S100A12 has been implicated in a novel inflammatory axis, involving RAGE, a multiligand receptor of the immunoglobulin superfamily expressed on endothelium and cells of the immune system [175, 196].

S100A12 binds to RAGE. The binding of S100A12 to RAGE results in activation of various intracellular signaling pathways. As a consequence, surface expression of vascular cell adhesion molecule 1 (VCAM-1) increases on endothelial cells after S100A12 stimulation. Enhanced binding of integrin very late activation antigen 4 – bearing mononuclear cells to S100A12-stimulated endothelium has been demonstrated [196]. In addition, S100A12 increased expression of intercellular adhesion molecule 1 (ICAM-1), thereby providing a mechanism by which polymorphonuclear leukocytes might be attracted to S100A12

stimulated endothelium as well [196]. Induction of VCAM-1 and ICAM-1 expression by S100A12 is, at least in part, mediated by activation of NF- κ B. S100A12 also exhibits direct chemotactic effects on phagocyte [197, 198]. Furthermore, activation of RAGE by S100A12 up-regulates expression of proinflammatory cytokines, such as tumor necrosis factor (TNF) and IL-1 β , by murine macrophage like BV-2 cells [196].

Peripheral blood mononuclear cells exposed to S100A12 displayed enhanced release of IL-2 into culture supernatants. In addition to these findings, an enhanced mitogenic response to crosslinking CD3/CD28 after stimulation of peripheral blood mononuclear cells with S100A12 was noted [196].

The mechanism of S100A12 action in detail (Fig. 6): 1) an initial pro-inflammatory stimulus, e.g. lipopolysaccharide (LPS) triggers - among others - the NF- κ B driven expression 2) of calgranulins via TLR4 expressed on granulocytes. 3) Proteins are released from cells via a tubulin-dependent alternative secretory pathway. 4) Once extracellular, S100A12 can bind TLR4 or RAGE on target cells. 5) In monocytes or granulocytes NF- κ B -dependent expression of pro-inflammatory cytokines like IL-1b, IL-6, IL-18 or TNF α are triggered. 6) IL-1 β in particular can in turn stimulate its own secretion by autocrine feedback-loops or trigger additional IL-1b release from other cells. 7) Finally, calgranulins can activate endothelial cells via TLR4- and RAGE-dependent pathways. This results in NF- κ B -driven expression of adhesion markers like intracellular and vascular adhesion molecules (ICAMs, VCAMs) or selectins on the microvascular endothelium. 8) In addition, monocytes and granulocytes are attracted along a chemokine (e.g. IL-8, MCP-1) gradient to the site of inflammation. Crossing the endothelium is facilitated by calgranulin-triggered upregulation of Mac-1 (CD11b-CD18) and its subsequent binding to ICAM-1. Thus, calgranulins in concert with IL-1 β are orchestrating a vicious autoinflammatory circle that is believed to be a key pathological mechanism in autoinflammatory diseases [199].

Taken together, the results of these in vitro studies demonstrated that released S100 proteins activate immune cells critical to pathogenesis of inflammation by triggering proliferation and generation of cytokines.

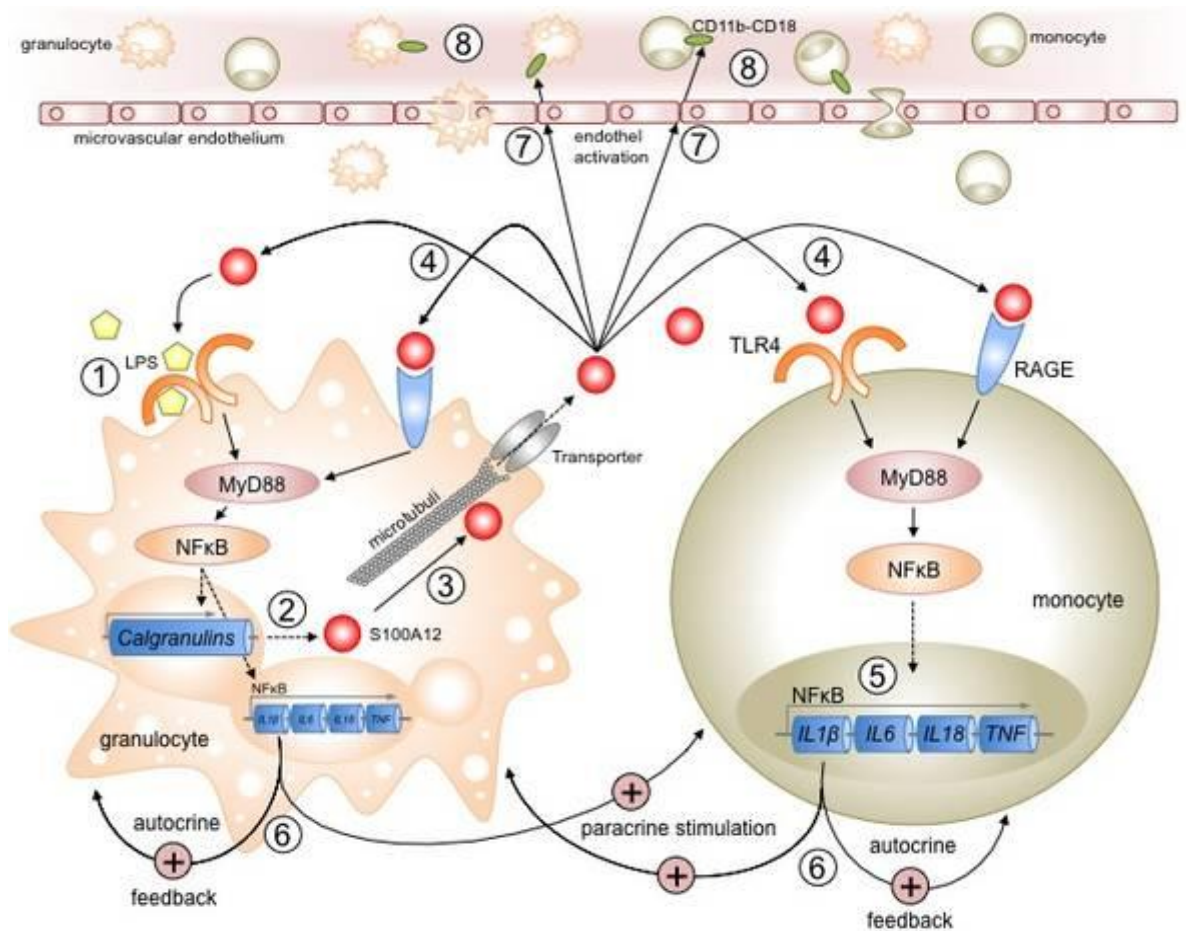

FIG. 6 S100A12 CAN PERPETUATE INFLAMMATORY MECHANISMS; (REPRINTED BY PERMISSION FROM ELSEVIER INC: CLINICAL IMMUNOLOGY 147, 229-241 (2013) [199].

Moreover S100A12 is suggested as a potent contributor to the development of atherosclerosis with vascular inflammation [173, 187]. In addition, recent data demonstrated that EN-RAGE could be a strong predictor for CV and all-cause mortality in HD patients [200, 201].

In summary, additional research will be necessary for better acceptance of EN-RAGE as a pro-inflammatory marker in patients with renal disease.

1.4.6 HIGH MOBILITY GROUP BOX PROTEIN-1 (HMGB-1)

The high mobility group (HMG) nuclear proteins were discovered in 1973 in an effort to better define the specific regulators of gene expression [202]. This group of non-histone, chromatin associated proteins has since been characterized to be involved in DNA organization and regulation of transcription.

HMGB-1 is member of a subfamily of the HMG proteins. The nuclear localization of HMGB-1 and its affinity for DNA is regulated through phosphorylation and acetylation, and has been found to have a dynamic relationship with chromatin [203].

The structure of HMGB-1 contains two separate 'boxes', the A- and B- boxes, each containing ~ 80 amino acids in an L-shaped fold, along with acidic C-terminal tale [204]. The B-box domain has been identified as important for many of the proinflammatory properties of HMGB-1 including cytokine release [205, 206]. The A-box domain does not possess the pro-inflammatory properties of the B-box and instead competes with HMGB-1 for binding sites leading to attenuation inflammatory cascade [207].

HMGB-1 is released passively during cellular necrosis by almost all cells which have nucleus and signals neighboring cells of ongoing damage [208]. However, HMGB-1 also is secreted actively by immune cells such as monocytes, macrophages, and dendritic cells [209-211].

Several important receptors have been implicated in HMGB-1 signaling, including receptor for advanced glycation end products (RAGE) and members of the Toll-like family receptors (TLRs). HMGB-1 signaling through RAGE promotes chemotaxis and the production of cytokines in a process that involves the transcription factor NF- κ B [212, 213]. Other RAGE dependent effects of HMGB-1 appear to involve the maturation [206, 214, 215] and migration [215-217] of immune cells as well as the upregulation of cell surface receptors [218, 219].

In addition to RAGE, Toll like family of receptors has been demonstrated to be important in HMGB-1 signaling. TLR4, TLR2, and TLR9 have been all implicated as HMGB-1 receptors. HMGB-1 binding of TLR2 and TLR4 results in NF- κ B upregulation [220, 221].

Extracellular HMGB-1 is also involved in the progression of several inflammatory diseases, including septic shock [209], disseminated intravascular coagulation [222], acute lung injury [211, 223], as well as chronic inflammatory diseases such as rheumatoid arthritis [224] and atherosclerosis [225, 226].

More recently studies in animal models demonstrated that HMGB-1 is an early mediator of injury and inflammation in liver, heart and kidney ischemia reperfusion injury [96, 227, 228]. Moreover, the only study in CKD patients has shown that HMGB-1 correlates with renal function as well as markers of inflammation and malnutrition in CKD patients [229].

In conclusion, further research in this area will improve our understanding the HMGB-1 mediated inflammatory response to the pathogenesis of renal disease.

1.4.7 EMERGING BIOMARKERS IN CHRONIC KIDNEY DISEASE AND ACUTE KIDNEY INJURY: FUTURE PERSPECTIVES

Recently, promising biomarkers have been identified for CKD and AKI. These may be more sensitive biomarkers of kidney function, the underlying pathophysiological and biochemical processes, and/or cardiovascular risk.

Potential biomarkers in the diagnosis of CKD and its progression referring to kidney function include cystatin C [230], β -trace protein [231], uric acid [232]. In addition, in patients with CKD, elevated levels of cystatin C are associated with all-cause mortality, cardiovascular events, and incident heart failure [233].

Biomarkers referring to kidney structure embrace neutrophil gelatinase associated lipocalin (NGAL) [234], kidney injury molecule 1 [235], N-acetyl- β -D-glucosaminidase [236], liver-type fatty acid binding protein [237], tenascin and tissue inhibitor of metalloproteinases 1 [238], glomerular injury including urinary nephrin, podocin and podocalyxin [239, 240]. NGAL was found to be a useful early predictor of AKI, with urine or plasma/serum NGAL levels functioning as well [241]

Biomarkers in the diagnosis of CKD and its progression with focus on endothelial dysfunction are intensively studied include asymmetric dimethylarginine (ADMA) [242], cardiovascular peptides [243, 244]. Brain natriuretic peptide (BNP) was prospectively studied as biomarker of cardiovascular events in CKD population in Japan, where the relative risk of cardiovascular events was significantly higher in those with the highest BNP levels [245]. ADMA is a strong predictor of cardiovascular and mortality in ESRD [246].

There are increasing numbers of inflammatory and fibrotic markers in CKD: C-reactive protein and soluble tumor necrosis factor receptor II [247, 248], pentraxin 3 [249], urinary IL-18 [250], transforming growth factor- β 1 [251], CD14 mononuclear cells in the urine [252].

Next group includes the biomarkers in the diagnosis of CKD and its progression in terms of metabolic factors such as fibroblast growth factor-23 (FGF-23) [253], apolipoprotein A-IV [254] and adiponectin [255]. Elevated levels of FGF-23 have been shown to be

predictive of mortality in ESRD and cardiovascular events in CKD patients starting dialysis [256].

Several markers including NGAL [257, 258], Kidney Injury Molecule -1 (KIM-1) [259, 260], interleukin (IL) -18 [261, 262], N -acetyl- β -D-glucosaminidase (NAG) [263], Fatty Acid Binding Protein (FABP) [264, 265], Netrin-1 [266], MCP-1 [267], osteopontin [268, 269] are intensively studied in AKI [270].

Serum creatinine, eGFR, and proteinuria are routinely used but the reliance on CKD progression, AKI and associated CVR may result in extensive time lapse where successful interventions could be tested and applied.

Therefore, new validated biomarkers are required for CKD progression, AKI, cardiovascular disease (CVD) risk and require further validation in diverse populations with renal disease before translation into clinical practice.

2 AIMS OF THE STUDY

The aim of this thesis is to study and compare the novel potential biomarkers in patients with renal diseases including CKD, HD, AKI patients and healthy controls for comparison. Moreover, the study aims to testify the hypothesis that these biomarkers are related to inflammatory and nutritional parameters, atherosclerosis, and cardiovascular disease.

1. Circulating serum PIGF levels in patients with decreased renal function:
 - Comparison of serum PIGF levels in patients with CKD, HD patients and healthy controls
 - Detection of the PIGF levels in the urine of CKD patients
 - Possible relationships of serum PIGF concentrations and markers of inflammation and atherosclerosis
2. Circulating serum EN-RAGE levels in patients with decreased renal function:
 - Comparison of serum EN-RAGE levels in patients with CKD, HD patients and healthy controls
 - Possible relationships of serum EN-RAGE levels to inflammatory markers in CKD, HD patients and healthy controls
3. Changes in MMP-2 and PAPP-A levels in CKD patients stages 1-5:
 - Comparison of MMP-2 and PAPP-A at each level of CKD
 - Biochemical determinants of MMP-2 and PAPP-A in CKD patients stages 1-5
4. Changes of MMP-2, MMP-9, PAPP-A in patients with various nephropathies:
 - Comparison of circulating levels of MMP-2, MMP-9 and PAPP-A in patients with various biopsy proven nephropathies
5. Evaluation of PIGF, PAPP-A, sRAGE, EN-RAGE and HMGB-1 levels in patients with acute kidney injury:
 - Comparison of PIGF, PAPP-A, sRAGE, EN-RAGE and HMGB-1 levels in AKI patients
 - Possible relationships of studied biomarkers to inflammatory markers and markers of nutrition

3 MATERIAL AND METHODS

3.1 METHODS

3.1.1 ENZYME IMMUNOASSAY FOR THE QUANTITATIVE DETERMINATION OF PLGF IN HUMAN SERUM

The Quantikine Human PIGF Immunoassay was used for the determination of PIGF concentrations in serum and urine (R&D Systems, Inc., Minneapolis, MN, USA www.RnDSystems.com).

3.1.1.1 PRINCIPLE OF THE ASSAY

This assay employs the quantitative sandwich enzyme immunoassay technique. A monoclonal antibody specific for PIGF has been pre-coated onto a microplate. Standards and samples are pipetted into the wells and any PIGF present is bound by the immobilized antibody. After washing away any unbound substances, an enzyme-linked polyclonal antibody specific for PIGF is added to the wells. Following a wash to remove any unbound antibody-enzyme reagent, a substrate solution is added to the wells and color develops in proportion to the amount of PIGF bound in the initial step. The color development is stopped and the intensity of color is measured, using a spectrophotometer microplate reader set at dual wavelength 450/570 nm.

3.1.1.2 MATERIALS AND REAGENTS

- PIGF Microplate – 96 well polystyrene microplate (12 strips of 8 wells) coated with a mouse monoclonal antibody against PIGF
- PIGF Conjugate – 21 mL/vial of polyclonal antibody against PIGF conjugated to horseradish peroxidase with preservative
- PIGF Standard – 1 ng/vial of recombinant human PIGF in a buffered protein base with preservative, lyophilized
- Assay Diluent RD1-22 – 11 ml/vial of a buffered protein base with preservative
- Calibrator Diluent RD 6-11 – 21 mL/vial of a buffered protein base with preservative
- Wash Buffer Concentrate – 21 ml/vial of a 25-fold concentrated solution of buffered surfactant with preservative

- Color Reagent A – 12.5 mL/vial of stabilized hydrogen peroxide
- Color Reagent B – 12.5 mL/vial of stabilized chromogen (tetramethylbenzidine)
- Stop Solution – 6 mL/vial of 2 N sulfuric acid
- Plate Covers – Adhesive strips.

3.1.1.3 SAMPLES

Blood was allowed to clot for 30 minutes before centrifugation for 10 minutes at 1450 g. Serum was frozen at -80°C . Urine was stored at -80°C . Analysis of all samples was performed within 6 months after collection.

3.1.1.4 ASSAY PROCEDURE

All reagents and samples were brought to room temperature before use. 20 mL of Wash Buffer Concentrate was diluted into distilled water to prepare 500 mL of Wash Buffer. To prepare Substrate Solution Color Reagents A and B were mixed together in equal volumes within 15 minutes of use. 200 μL of the resultant mixture was required per well. The PIGF Standard was reconstituted with 1.0 mL of Calibrator Diluent RD6-11 for serum samples, or Calibrator Diluent RD6-11 (1/2 \times) for urine samples. 10 mL of Calibrator Diluent RD6-11 was added to 10 mL of distilled water to prepare 20 mL of Calibrator Diluent RD6-11 for urine samples. The reconstitution produced a stock solution of 1000 pg/mL. The standard was allowed to sit of 15 minutes with gentle agitation prior to making dilutions. 500 μL of the appropriate Calibrator Diluent was pipetted into each tube. The stock solution was used to produce a dilution series with 500 pg/mL, 250 pg/mL, 125 pg/mL, 62.5 pg/mL, 31.2 pg/mL, 15.6 pg/mL. Each tube was mixed before next transfer. The undiluted standard served as the high standard (1000 pg/mL). The Calibrator Diluent RD6-11 served as the zero standard (0 pg/mL).

1. 100 μL of Assay Diluent RD1-22 was added to each well.
2. 100 μL of Standard, control, and sample was added per well and covered with adhesive strip provided. Subsequently the plate layout was incubated for two hours at room temperature.
3. Each well was aspirated and washed, repeating the process three times for a total of four washes with Wash Buffer (400 μL). Complete removal of liquid at each step was

essential to good performance. After the last wash, any remaining Wash Buffer was removed by aspirating. The plate was inverted and blotted against clean paper towels.

4. 200 μ L of PIGF Conjugate was added to each well covered with a new adhesive strip. The plate was incubated for two hours at room temperature. The aspiration and wash was repeated as in step (3).
5. 200 μ L of Substrate Solution was added to each well. The plate, protected from light, was incubated for 30 minutes at room temperature.
6. 50 μ L of Stop Solution was added to each well. The color in the wells was changed from blue to yellow.
7. The optical density of each well was determined within 30 minutes, using a spectrophotometer microplate reader set at dual wavelength 450/570 nm.

The PIGF concentration of the sample was read from a calibration curve, using *Genesis* software. The minimum detectable dose of PIGF was 7 pg/mL.

3.1.1.5 MEASUREMENT

Spectrophotometer Lab Systems, Multiscan RC, Finland was used set at dual wavelength 450/570 nm. The concentrations of PIGF are given in pg/mL.

3.1.2 ENZYME IMMUNOASSAY FOR THE QUANTITATIVE DETERMINATION OF RAGE IN HUMAN SERUM

The Quantikine Human RAGE Immunoassay was used for the determination of soluble RAGE concentrations in serum (R&D Systems, Inc., Minneapolis, MN, USA www.RnDSystems.com).

3.1.2.1 PRINCIPLE OF THE ASSAY

This assay employs the quantitative sandwich enzyme immunoassay technique. A monoclonal antibody specific for RAGE (extracellular domain) has been pre-coated onto a microplate. Standards and samples are pipetted into the wells and any RAGE present is bound by the immobilized antibody. After washing away any unbound substances, an enzyme-linked polyclonal antibody specific for RAGE (extracellular domain) is added to the wells. Following a wash to remove any unbound antibody-enzyme reagent, a substrate solution is added to the wells and color develops in proportion to the amount of RAGE bound in the

initial step. The color development is stopped and the intensity of the color is measured, using a spectrophotometer microplate reader set at dual wavelength 450/570 nm.

3.1.2.2 MATERIALS AND REAGENTS

- RAGE Microplate – 96 well polystyrene microplate (12 strips of 8 wells) coated with a mouse monoclonal antibody against RAGE
- RAGE Conjugate – 21 mL/vial of polyclonal antibody against RAGE conjugated to horseradish peroxidase with preservatives
- RAGE Standard – 50 ng/vial of recombinant human RAGE/Fc Chimera in a buffer with preservatives, lyophilized
- Assay Diluent RD1-60 – 11 ml/vial of a buffered protein base with preservative and blue dye
- Calibrator Diluent RD6-10 – 21 mL/vial of a buffered protein base with preservatives
- Wash Buffer Concentrate – 21 ml/vial of a 25-fold concentrated solution of buffered surfactant with preservatives
- Color Reagent A – 12.5 mL/vial of stabilized hydrogen peroxide
- Color Reagent B – 12.5 mL/vial of stabilized chromogen (tetramethylbenzidine)
- Stop Solution – 6 mL/vial of 2 N sulfuric acid
- Plate Covers – Adhesive strips.

3.1.2.3 SAMPLES

Blood was allowed to clot for 30 minutes before centrifugation for 10 minutes at 1450 g. Serum was frozen at -80°C . Analysis of all samples was performed within 6 months after collection.

3.1.2.4 ASSAY PROCEDURE

All reagents and samples were brought to room temperature before use. 20 mL of Wash Buffer Concentrate was diluted into distilled water to prepare 500 mL of Wash Buffer. To prepare Substrate Solution Color Reagents A and B were mixed together in equal volumes within 15 minutes of use. 200 μL of the resultant mixture was required per well. The RAGE

Standard was reconstituted with 1.0 mL of distilled water. The reconstitution produced a stock solution of 50,000 pg/mL. The standard was allowed to sit for 15 minutes with gentle agitation prior to making dilutions. 100 μ L of the stock solution and 900 μ L of the appropriate Calibrator Diluent RD6-10 was pipetted into the 5000 pg/mL tube. 500 μ L of appropriate Calibrator Diluent was pipetted into the remaining tubes. The stock solution was used to produce a dilution series with 2500 pg/mL, 1250 pg/mL, 625 pg/mL, 312 pg/mL, 156 pg/mL, 78 pg/mL. Each tube was mixed before next transfer. The undiluted standard served as the high standard (5000 pg/mL). The appropriate Calibrator Diluent RD6-10 served as the zero standard (0 pg/mL).

1. 100 μ L of Assay Diluent RD1-60 was added to each well.
2. 50 μ L of Standard, control, and sample was added per well and covered with adhesive strip provided. Subsequently the plate layout was incubated for two hours at room temperature.
3. Each well was aspirated and washed, repeating the process three times for a total of four washes with Wash Buffer (400 μ L). Complete removal of liquid at each step was essential to good performance. After the last wash, any remaining Wash Buffer was removed by aspirating. The plate was inverted and blotted against clean paper towels.
4. 200 μ L of RAGE Conjugate was added to each well covered with a new adhesive strip. The plate was incubated for two hours at room temperature. The aspiration and wash was repeated as in step (3).
5. 200 μ L of Substrate Solution was added to each well. The plate, protected from light, was incubated for 30 minutes at room temperature.
6. 50 μ L of Stop Solution was added to each well. The color in the wells was changed from blue to yellow.
7. The optical density of each well was determined within 30 minutes, using a spectrophotometer microplate reader set at dual wavelength 450/570 nm.

The soluble RAGE concentration of the sample was read from a calibration curve, using *Genesis* software. The minimum detectable dose of soluble RAGE was 4.12 pg/mL.

3.1.2.5 MEASUREMENT

Spectrophotometer Lab Systems, Multiscan RC, Finland was used set at dual wavelength 450/570 nm. The concentrations of RAGE are given in pg/mL.

3.1.3 ENZYME IMMUNOASSAY FOR THE QUANTITATIVE DETERMINATION OF MMP-2 IN HUMAN SERUM

The Quantikine Human MMP-2 Immunoassay was used for the determination of soluble MMP-2 concentrations in serum (R&D Systems, Inc., Minneapolis, MN, USA www.RnDSystems.com).

3.1.3.1 PRINCIPLE OF THE ASSAY

This assay employs the quantitative sandwich enzyme immunoassay technique. A polyclonal antibody specific for MMP-2 has been pre-coated onto a microplate. Standards and samples are pipetted into the wells and any MMP-2 present is bound by the immobilized antibody. After washing away any unbound substances, an enzyme-linked polyclonal antibody specific for MMP-2 is added to the wells. Following a wash to remove any unbound antibody-enzyme reagent, a substrate solution is added to the wells and color develops in proportion to the amount of MMP-2 bound in the initial step. The color development is stopped and the intensity of the color is measured, using a spectrophotometer microplate reader set at dual wavelength 450/570 nm.

3.1.3.2 MATERIALS AND REAGENTS

- MMP-2 Microplate – 96 well polystyrene microplate (12 strips of 8 wells) coated with a polyclonal antibody against MMP-2
- MMP-2 Conjugate – 21 mL of a polyclonal antibody against MMP-2 conjugated to horseradish peroxidase with preservatives
- MMP-2 Standard – 100 ng of recombinant human MMP-2 in a buffered protein solution with preservatives, lyophilized
- Assay Diluent RD1-74 – 11 ml of a buffered protein solution with preservatives
- Calibrator Diluent RD5-32 – 21 mL of a buffered protein solution with preservatives
- Wash Buffer Concentrate – 21 mL of a 25-fold concentrated solution of a buffered surfactant with preservatives
- Color Reagent A – 12.5 mL of stabilized hydrogen peroxide

- Color Reagent B – 12.5 mL of stabilized chromogen (tetramethylbenzidine)
- Stop Solution – 6 mL of 2 N sulfuric acid
- Plate Covers – 4 Adhesive strips

3.1.3.3 SAMPLES

Blood was allowed to clot for 30 minutes before centrifugation for 10 minutes at 1450 g. Serum was frozen at -80°C . Analysis of all samples was performed within 6 months after collection.

3.1.3.4 ASSAY PROCEDURE

All reagents and samples were brought to room temperature before use. 20 mL of Wash Buffer Concentrate was diluted into distilled water to prepare 500 mL of Wash Buffer. To prepare Substrate Solution Color Reagents A and B were mixed together in equal volumes within 15 minutes of use. 200 μL of the resultant mixture was required per well. The MMP-2 Standard was reconstituted with 1.0 mL of distilled water. The reconstitution produced a stock solution of 100 ng/mL. The standard was allowed to sit of 15 minutes with gentle agitation prior to making dilutions. 200 μL of the Calibrator Diluent RD5-32 was pipetted into 50 ng/mL tube. 200 μL of Calibrator Diluent RD5-32 was pipetted into the remaining tubes. The stock solution was used to produce a dilution series: with 25 ng/mL, 12.5 ng/mL, 6.25 ng/mL, 3.13 ng/mL, 0.78 ng/mL. Each tube was mixed before next transfer. The 50 ng/mL standard served as the high standard. The Calibrator Diluent RD5-32 served as the zero standard (0 ng/mL).

1. 100 μL of Assay Diluent RD1-74 was added to each well.
2. 50 μL of Standard, control, and diluted samples was added per well and covered with adhesive strip provided. Serum required 10-fold dilution (20 μL of sample and 180 μL of Calibrator Diluent RD5-32). Subsequently the plate layout was incubated for two hours at room temperature on the microplate shaker set at 450 rpm. .
3. Each well was aspirated and washed, repeating the process three times for a total of four washes with Wash Buffer (400 μL). Complete removal of liquid at each step was essential to good performance. After the last wash, any remaining Wash Buffer was removed by aspirating. The plate was inverted and blotted against clean paper towels.

4. 200 μ L of MMP-2 Conjugate was added to each well covered with a new adhesive strip. The plate was incubated for two hours at room temperature on the shaker.. The aspiration and wash was repeated as in step (3).
5. 200 μ L of Substrate Solution was added to each well. The plate, protected from light, was incubated for 30 minutes at room temperature on the benchtop.
6. 50 μ L of Stop Solution was added to each well. The color in the wells was changed from blue to yellow.
7. The optical density of each well was determined within 30 minutes, using a spectrophotometer microplate reader set at dual wavelength 450/570 nm.

The MMP-2 concentration of the sample was read from a calibration curve, using *Genesis* software. The minimum detectable dose of MMP-2 was 0.047 ng/mL.

3.1.3.5 MEASUREMENT

Spectrophotometer Lab Systems, Multiscan RC, Finland was used set at dual wavelength 450/570 nm. The concentrations of MMP-2 are given in ng/mL.

3.1.4 ENZYME IMMUNOASSAY FOR THE QUANTITATIVE DETERMINATION OF MMP-9 IN HUMAN SERUM

The Quantikine Human MMP-9 Immunoassay was used for the determination of soluble MMP-9 concentrations in serum and urine (R&DSystems, Inc., Minneapolis, MN, USA www.RnDSystems.com).

3.1.4.1 PRINCIPLE OF THE ASSAY

This assay employs the quantitative sandwich enzyme immunoassay technique. A monoclonal antibody specific for MMP-9 has been pre-coated onto a microplate. Standards and samples are pipetted into the wells, and MMP-9 is bound by the immobilized antibody. After washing away unbound substances, an enzyme-linked polyclonal antibody specific for MMP-9 is added to the wells. Following a wash to remove unbound antibody-enzyme reagent, a substrate solution is added to the wells and color develops in proportion to the amount of total MMP-9 bound in the initial step. The color development is stopped and the intensity of the color is measured, using a spectrophotometer microplate reader set at dual wavelength 450/570 nm.

3.1.4.2 MATERIALS AND REAGENTS

- Total MMP-9 Microplate – 96 well polystyrene microplate (12 strips of 8 wells) coated with a mouse monoclonal antibody against MMP-9
- Total MMP-9 Conjugate – 21 mL/vial of a polyclonal antibody against MMP-9 conjugated to horseradish peroxidase with preservatives
- Total MMP-9 Standard – 20 ng/vial of recombinant human MMP-9 in a buffered protein solution with preservatives, lyophilized
- Assay Diluent RD1-34 – 11 ml of a buffered protein solution with preservatives
- Calibrator Diluent RD5-10 – 21 mL/vial of a concentrated buffered protein base with preservatives
- Wash Buffer Concentrate – 21 mL/vial of a 25-fold concentrated solution of a buffered surfactant with preservatives
- Color Reagent A – 12.5 mL of stabilized hydrogen peroxide;
- Color Reagent B – 12.5 mL of stabilized chromogen (tetramethylbenzidine)
- Stop Solution – 6 mL/vial of 2 N sulfuric acid
- Plate Covers – 4 Adhesive strips.

3.1.4.3 SAMPLES

Blood was allowed to clot for 30 minutes before centrifugation for 10 minutes at 1450 g. Serum was frozen at -80°C . Analysis of all samples was performed within 6 months after collection.

3.1.4.4 ASSAY PROCEDURE

All reagents and samples were brought to room temperature before use. 20 mL of Wash Buffer Concentrate was diluted into distilled water to prepare 500 mL of Wash Buffer. To prepare Substrate Solution Color Reagents A and B were mixed together in equal volumes within 15 minutes of use. 200 μL of the resultant mixture was required per well. The MMP-2 Standard was reconstituted with 1.0 mL of distilled water. The reconstitution produced a stock solution of 20 ng/mL. The standard was allowed to sit for 15 minutes with gentle agitation

prior to making dilutions. 500 μL of the Calibrator Diluent RD5-10 was pipetted into each tube. The stock solution was used to produce a dilution series: 10ng/mL, 5 ng/mL, 2.5 ng/mL, 1.125 ng/mL, 0.625 ng/mL, 0.312 ng/mL. Each tube was mixed before next transfer. The 20 ng/mL standard served as the high standard. The Calibrator Diluent RD5-10 served as the zero standard (0 ng/mL).

1. 100 μL of Assay Diluent RD1-34 was added to each well.
2. 100 μL of Standard, control, and diluted sample was added per well and covered with adhesive strip provided. Samples required a 10-fold dilution (5 μL of sample and 450 μL of Calibrator Diluent RD5-10). Subsequently the plate layout was incubated for two hours at room temperature on microplate shaker set at 450 rpm.
3. Each well was aspirated and washed, repeating the process three times for a total of four washes with Wash Buffer (400 μL). Complete removal of liquid at each step was essential to good performance. After the last wash, any remaining Wash Buffer was removed by aspirating. The plate was inverted and blotted against clean paper towels.
4. 200 μL of MMP-9 Conjugate was added to each well covered with a new adhesive strip. The plate was incubated for one hour at room temperature on the shaker. The aspiration and wash was repeated as in step (3).
5. 200 μL of Substrate Solution was added to each well. The plate, protected from light, was incubated for 30 minutes at room temperature on the benchtop.
6. 50 μL of Stop Solution was added to each well. The color in the wells was changed from blue to yellow.
7. The optical density of each well was determined within 30 minutes, using a spectrophotometer microplate reader set at dual wavelength 450/570 nm.

The MMP-9 concentration of the sample was read from a calibration curve, using *Genesis* software. The minimum detectable dose of MMP-9 was 0.156 ng/mL.

3.1.4.5 MEASUREMENT

Spectrophotometer Lab Systems, Multiscan RC, Finland was used set at dual wavelength 450/570 nm. The concentrations of MMP-9 are given in ng/mL.

3.1.5 TIME RESOLVED AMPLIFIED CRYPTATE EMISSION IMMUNOFLUORESCENT ASSAY FOR THE QUANTITATIVE DETERMINATION OF PAPP-A IN HUMAN SERUM

The KRYPTOR automated immunofluorescent assay was used for the quantitative determination of PAPP-A in serum (Thermo Fisher, Scientific, BRAHMS GmbH; Hennigsdorf, Germany www.brahms.de).

3.1.5.1 PRINCIPLE OF THE ASSAY

The measurement principle of KRYPTOR is based on TRACE[®] Technology (Time Resolved Amplified Cryptate Emission), which measures the signal emitted from an immunocomplex with time delay. The basis of the TRACE[®] Technology is non-radiative energy transfer from donor (a cage like structure with an europium ion in the center [cryptate]) to an acceptor, which is part of a chemically modified, light-collecting algal protein (XL 665). The proximity of donor (cryptate) and acceptor (XL 665) when they are part of an immunocomplex and the spectral overlap between donor emission and acceptor absorption spectra on the one hand, intensity the fluorescent signal of the cryptate and on the other hand they extend the life span of the acceptor signal, permitting the measurement of temporally delayed fluorescence.

When the sample is excited with a nitrogen laser at 337 nm, the donor (cryptate) emits a long-life fluorescent signal in the mill-second range at 620 nm, while the acceptor (XL 665) generates a short-life signal in the nanosecond-range at 665 nm. When the two components are bound in an immunocomplex, both the signal amplification and the prolongation of the life span of the acceptor signal occur at 665 nm, so that it can be measured over μ -seconds. This long-life signal is proportional to the concentration of the analyte to be measured.

Non-specific signals, e.g. the signals of the short-life and unbound acceptor XL 665 and the medium-specific interference signals conditional upon the natural fluorescence measurement. The signal generated by the cryptate at 620 nm serves as an internal reference and is measured simultaneously with the long-life acceptor signal at 665 nm which is the specific signal. Interfering influence, e.g. from the turbid sera, are automatically corrected by means of the internally calculated ratio of the intensities at these wavelengths.

3.1.5.2 MATERIALS AND REAGENTS

- Cryptate Conjugate – 4.5 mL/vial of anti-PAPP-A monoclonal antibody conjugated with europium cryptate, buffer, bovine albumin, unspecific mice immunoglobulins, potassium fluoride
- Diluent – 9 mL/vial of a new born calf serum with preservatives
- XL665-Conjugate – 5.6 mL/vial of anti-PAPP-A monoclonal antibody conjugated with XL 665, buffer, bovine albumin, unspecific mice immunoglobulins, potassium fluoride

3.1.5.3 SAMPLES

Blood was allowed to clot for 30 minutes before centrifugation for 10 minutes at 1450 g. Serum was frozen at -80°C . Analysis of all samples was performed within 6 months after collection.

3.1.5.4 ASSAY PROCEDURE

1. All reagents and samples were brought to room temperature before use. Conjugates and the sample (50 μL) were dispensed into the reaction plate and the signal emitted was measured periodically.
2. After the measurement of fluorescent signal, the data obtained from the software were compared to the memorized standard curve.
3. The minimum detectable dose of PAPP-A was 4 mIU/L.

3.1.5.5 MEASUREMENT

KRYPTOR Thermo Fisher, Scientific, BRAHMS GmbH; Hennigsdorf, Germany was used set. The concentrations of PAPP-A are given in mIU/L.

3.1.6 ENZYME IMMUNOASSAY FOR THE QUANTITATIVE DETERMINATION OF S100A12/EN-RAGE IN HUMAN SERUM

The CircuLex S100A12/EN-RAGE ELISA Kit was used for the quantitative determination of S100A12/EN-RAGE concentrations in serum (CycLex Co., Ltd, Nagano, Japan www.cyclex.co.jp).

3.1.6.1 PRINCIPLE OF THE ASSAY

The CircuLex S100A12/EN-RAGE ELISA Kit employs the quantitative sandwich enzyme immunoassay technique. A monoclonal antibody specific for S100A12/EN-RAGE has been pre-coated onto a microplate. Standards and samples are pipetted into the wells and the immobilized antibody binds any S100A12/EN-RAGE present. After washing away any unbound substances, an HRP conjugated polyclonal antibody specific for S100A12/EN-RAGE is added to the wells. Following a wash to remove any unbound antibody HRP conjugate, the remaining conjugate is allowed to react with the substrate H₂O₂-tetramethylbenzidine. The color development is stopped by addition of acidic solution and the intensity of the color is measured, using a spectrophotometer microplate reader set at dual wavelength 450/570 nm.

The absorbance is proportional to the concentration of S100A12/EN-RAGE. A standard curve is constructed by plotting absorbance values versus S100A12/EN-RAGE concentrations of calibrators, and concentrations of unknown samples are determined using this standard curve.

3.1.6.2 MATERIALS AND REAGENTS

- Total S100A12/EN-RAGE Microplate – 96 well polystyrene microplate (12 strips of 8 wells) coated with a monoclonal antibody against S100A12/EN-RAGE
- 10x Wash Buffer – 100 mL of 10x buffer containing 2% Tween[®]-20
- 5x Dilution Buffer – one bottle containing 20 mL of 5X buffer, diluted 5 times and used for sample dilution
- S100A12 Standard – one vial containing 510 ng of lyophilized recombinant S100A12/EN-RAGE
- 20x HRP conjugated Detection Antibody – one vial containing 0.6 horseradish peroxidase conjugated anti-S100A12/EN-RAGE polyclonal antibody
- Conjugate Dilution Buffer - one bottle containing 12 mL of Conjugate Dilution Buffer
- Substrate Reagent – one bottle containing 20 mL of the chromogenic substrate, tetramethylbenzidine, ready to use

- Stop Solution – one bottle containing 20 mL of 1 N sulfuric acid, ready to use.

3.1.6.3 SAMPLES

Blood was allowed to clot for 30 minutes before centrifugation for 10 minutes at 1450 g. Serum was frozen at -80°C . Analysis of all samples was performed within 6 months after collection.

3.1.6.4 ASSAY PROCEDURE

1. All reagents and samples were brought to room temperature before use. Serum samples were diluted 1:200 (5 μL serum sample and 995 μL dilution buffer).
2. 100 μL of S100A12/EN-RAGE Standards and diluted samples were pipetted in duplicates, into the appropriate wells.
3. The plate was incubated at room temperature for one hour on the shaker at 300 rpm.
4. Each well was washed 4-times by filling Wash Buffer (350 μL).
5. 100 μL of HRP conjugated Detection Antibody was added into each well.
6. The plate was incubated for one hour at room temperature on the shaker at 300 rpm.
7. Each well was washed 4 times by filling with Wash Buffer (350 μL).
8. 100 μL of Substrate Reagent was added.
9. The plate was incubated for 15-20 minutes at room temperature.
10. 100 μL of Stop Solution was added to each well.

The optical density of each well was determined within 30 minutes, using a spectrophotometer microplate reader set at dual wavelength of 450/570 nm.

The S100A12/EN-RAGE concentration of the sample was read from a calibration curve, using *Genesis* software. The minimum detectable dose of S100A12/EN-RAGE was 56 ng/mL.

3.1.6.5 MEASUREMENT

Spectrophotometer Lab Systems, Multiscan RC, Finland was used at dual lengths of 450/570 nm. The concentrations of S100A12/EN-RAGE are given in ng/mL.

3.1.7 ENZYME IMMUNOASSAY FOR THE QUANTITATIVE DETERMINATION OF HMGB-1 IN HUMAN SERUM

The IBL International HMGB-1 ELISA kit was used for the determination of HMGB-1 concentrations in serum (IBL International GmbH, Hamburg, Germany www.IBL-international.com).

3.1.7.1 PRINCIPLE OF THE ASSAY

HMGB-1 ELISA is a sandwich-enzyme immunoassay for the quantitative determination of HMGB-1 in serum and plasma. The wells of the microtiter strips are coated with purified anti-HMGB-1 antibody. HMGB-1 in the sample binds specifically to the immobilized antibody and is recognized by a second enzyme marked antibody. After substrate reaction the HMGB-1 concentration is determined by the color intensity.

3.1.7.2 MATERIALS AND REAGENTS

- Microtiter Plate – 96 well polystyrene microplate (12 strips of 8 wells) coated with a polyclonal antibody against HMGB-1
- Enzyme Conjugate contains HMGB-1 conjugated to peroxidase
- Standard Solution – contains pig HMGB-1
- Positive Control contains pig HMGB-1
- Diluent Buffer – ready to use, contains buffer 0.01% NaN₃
- Enzyme Conjugate Diluent – ready to use, contains buffer
- Wash Buffer concentrate 5x – contains phosphate buffer, <0.5 % Tween 20
- Color Reagent A - contains TMB
- Color Reagent B - contains buffer with 0.005 M hydrogen peroxide
- Color Stop Solution – ready to use, contains 0.35 M H₂SO₄
- Adhesive foil.

3.1.7.3 SAMPLES

Blood was allowed to clot for 30 minutes before centrifugation for 10 minutes at 1450 g. Serum was frozen at –80 °C. Analysis of all samples was performed within 6 months after collection.

3.1.7.4 ASSAY PROCEDURE

1. All reagents and samples were brought to room temperature before use and each vial of liquid reagent and sample were gently swirled before use. 50 μ L of Diluent Buffer were pipetted into the respective wells of the microtiter plate.
2. 50 μ L of Standard, positive control and each of serum sample were pipetted into the respective wells of Microtiter Plate, shaking briefly 30 seconds.
3. The plate was covered with adhesive foil and incubated 24 hours at + 37 °C.
4. The adhesive foil was removed and incubation solution was discarded. The plate was washed 5 times with 400 μ L diluted Wash Buffer. Excess solution was removed by tapping with inverted plate on a paper towel.
5. 100 μ L of Enzyme Conjugate was pipetted into each well.
6. The plate was covered with adhesive foil and incubated for 2 hours at +25 °C.
7. The adhesive foil was removed. Incubation solution was discarded. The plate was washed 5 times with 400 μ L diluted Wash buffer. Excess solution was removed by tapping the inverted plate on a paper towel.
8. 100 μ L of Color Solution was pipetted into each well.
9. The plate was incubated 30 minutes at room temperature.
10. The color reaction was stopped by adding 100 μ L of Stop Solution into each well. Contents were briefly mixed by gently shaking the plate.

The optical density of each well was determined within 60 minutes, using a spectrophotometer microplate reader set at dual wavelength of 450/620 nm.. The concentration of the samples was read directly from the standard curve. The minimum detectable dose of HMGB-1 was 1.4 ng/mL.

3.1.7.5 MEASUREMENT

Spectrophotometer Lab Systems, Multiscan RC, Finland was used at dual wavelength of 450/620 nm. The concentrations of HMGB-1 are given in ng/mL.

3.1.8 MEASUREMENT OF OTHER PARAMETERS

Routine laboratory parameters were assessed by commercially available kits using standard laboratory techniques.

- Serum creatinine was determined using Jaffé method (Modular analyzer, Roche Diagnostics GmbH, Germany).
- Total protein measurement on the 24-h urine sample was performed on the Roche Modular System (pyrogallol red) (Modular analyzer, Roche Diagnostics GmbH, Germany) on the same day as collections were completed.
- Total cholesterol was evaluated enzymatically (Modular analyzer, Roche Diagnostics GmbH, Germany).
- C-reactive protein (CRP) was determined turbidimetrically (Roche Diagnostics, Modular analyzer, Roche Diagnostics GmbH, Germany).
- Orosomucoid (acidic α 1-glycoprotein) and α -2 Macroglobulin were assessed nephelometrically (Image, Beckman Coulter, USA).
- Fibrinogen was measured by the trombin method (Clauss).
- Albumin was determined by photometry with bromocresole green (Roche Diagnostics, Modular analyzer, Roche Diagnostics GmbH, Germany).
- Prealbumin measurement was performed turbidimetrically (Roche Diagnostics, Modular analyzer, Roche Diagnostics GmbH, Germany).
- Blood count was measured with an automated haematological Beckman Coulter LH750 Hematology analyzer (Beckman Coulter, USA).

The eGFR was calculated using the MDRD formula [271].

All the measurements were performed according to the manufacturer's instructions; results were calculated by reference to standard curves.

3.2 SUBJECTS

3.2.1 PLACENTAL GROWTH FACTOR IN PATIENTS WITH CHRONIC KIDNEY DISEASE

PIGF was studied in patients with CKD and various degrees of decreased renal function (CHRI), HD patients, and age matched healthy controls. All patients were in stable clinical status at the time of the study, without signs of acute infection or acute cardiac problems. Written informed consent and laboratory samples were obtained from all subjects according to ethical guidelines. The study was performed in adherence to the principles of the Declaration of Helsinki and approved by the Institutional Ethical Committee.

3.2.1.1 PATIENTS WITH CKD

The group of patients with CKD not yet dialyzed (CHRI group) consisted of 45 patients, 28 males and 17 females with mean age 61 ± 15 years. Their GFR ranged from 0.10 to 2.137 mL/s/1.73 m² (median 0.39 mL/s/1.73 m²), and proteinuria ranged from 0.04 to 11.6 g/24 hours. The duration of their renal diseases was from a minimum of 5 months to a maximum of 31 years. Causes of nephropathy were immunoglobulin A nephritis (IgA) in 10 patients, membranous nephropathy in 2 patients, hypertensive nephropathy in 13 patients, diabetic nephropathy in 3 patients, interstitial nephritis in 7 patients, cystic kidney disease in 6 patients, and multifactorial in 4 patients. The majority of the patients had hypertension and was treated with moderate doses of antihypertensive drugs. Fourteen patients had diabetes type 2. Twenty-six patients had dyslipidemia and were treated with statins.

3.2.1.2 PATIENTS WITH ESRD TREATED WITH HD

The HD group consisted of 31 long-term HD patients, 15 males and 16 females, mean age 59 ± 15 years. Causes of renal failure were as follows: glomerulonephritis in 4 patients, hypertensive nephropathy in 4 patients, cystic kidney disease in 7 patients, interstitial nephritis in 5 patients, diabetic nephropathy in 4 patients, and multifactorial in 7 patients. Their mean residual diuresis was 660 ± 694 mL/24 h. The majority of patients were dialyzed 3 times/week for 4 hours, and their dialysis treatment lasted for 3 months to 17 years. They received $1,500\pm 658$ IU heparin per session; their mean ultrafiltration rate was 598 mL/hour, and Kt/V 1.46 ± 0.2 . HD treatment was performed using conventional bicarbonate-buffered dialysate in all patients. Of all patients, 91% used native arteriovenous fistulae for dialysis; in other cases arteriovenous fistulae with artificial graft were used. 10 patients were dialyzed with high flux dialyzers and, in the rest of the group low flux dialyzers were used. Dialyzers were made of polysulphone (35.5%), diacetate cellulose (48.3%), and triacetate cellulose (16.2%). The majority of the patients had hypertension and was treated with moderate doses of antihypertensive drugs. Eight patients had type 2 diabetes treated with insulin or peroral antidiabetics. 14 patients had dyslipidemia treated by statins. They were administered an average weekly erythropoietin 109 IU/kg body weight.

3.2.1.3 CONTROL GROUP

The control group consisted of 38 age matched healthy subjects, 16 males and 12 females, mean age 57 ± 8 years. They were not administered any special alimentary supplements at the time of the study.

3.2.1.4 SAMPLES

In HD patients, blood was collected via puncture of the arteriovenous fistula before starting the dialysis session and prior to heparin administration. In other subjects, blood was collected after overnight fasting via puncture of the cubital vein, simultaneously with blood collection for routine control examinations. Blood was centrifuged for 10 minutes at 1,450 g, and serum was frozen at -80°C . Additionally, in about half of the patients with renal insufficiency not yet dialyzed, a 24-hour urine sample was collected, frozen, and also used for analysis. Analysis of all samples was performed within 6 months after collection.

3.2.1.5 LABORATORY PARAMETERS

In all patients and controls PIGF levels and other biochemical parameters were measured using methods as were described above in the text.

3.2.2 SERUM S100A12 (EN-RAGE) LEVELS IN PATIENTS WITH DECREASED RENAL FUNCTION AND SUBCLINICAL CHRONIC INFLAMMATORY DISEASE

S100A12 was studied in patients with CKD and various degrees of decreased renal function (CHRI), HD patients, and healthy controls. All patients were in stable clinical status at the time of the study, without signs of acute infection or acute cardiac problems. A sub-analysis was performed comparing S100A12 values in patients with lower < 6.5 mg/L and higher > 6.5 mg/L CRP levels in both studied groups. Written informed consent and laboratory samples were obtained from all subjects according to ethical guidelines. The study was performed in adherence to the principles of the Declaration of Helsinki and approved by the Institutional Ethical Committee.

3.2.2.1 PATIENTS WITH CKD

The group of CKD patients not yet dialyzed (CHRI group) consisted of 46 patients. Their GFR ranged from 0.10 to 2.137 mL/s/1.73 m² (median 0.39 mL/s/1.73 m²), and proteinuria ranged from 0.04 to 11.6 g/24 hours. The duration of their renal diseases was from a minimum of 5 months to a maximum of 31 years. Causes of nephropathy were IgA nephritis in 11 patients, membranous nephropathy in 2 patients, hypertensive nephropathy in 13 patients, diabetic nephropathy in 3 patients, interstitial nephritis in 7 patients, cystic kidney disease in 6 patients, and multifactorial in 4 patients. The majority of the patients had hypertension and were treated with moderate doses of antihypertensive drugs. Fourteen patients had diabetes type 2. Twenty-six patients had dyslipidemia and were treated with statins.

3.2.2.2 PATIENTS WITH ESRD TREATED WITH HD

The same group of HD patients as in the first study was used.

3.2.2.3 CONTROL GROUP

The control group consisted of 24 healthy subjects. They were not administered any special alimentary supplements at the time of the study.

3.2.2.4 SAMPLES

In HD patients, blood was collected via puncture of the arteriovenous fistula before starting the dialysis session and prior to heparin administration. In other subjects, blood was collected after overnight fasting via puncture of the cubital vein, simultaneously with blood collection for routine control examinations. Blood was centrifuged for 10 minutes at 1,450 g, and serum was frozen at -80°C . Analysis of all samples was performed within 6 months after collection.

3.2.2.5 LABORATORY PARAMETERS

In all patients and controls S100A12/EN-RAGE levels and other biochemical parameters were measured using methods as were described above in the text. GFR was calculated by 24-hour urine collection.

3.2.3 DETERMINANTS OF CIRCULATING MMP-2 AND PAPP-A IN PATIENTS WITH CHRONIC KIDNEY DISEASE

159 white patients at different stages of CKD were included in a cross-sectional study. All enrolled patients were in stable clinical status at the time of the study, without signs of acute infection, tumor or acute cardiac problems. The control group consisted of 44 healthy subjects. Written informed consent and laboratory samples were obtained from all subjects according to ethical guidelines. The study was performed in adherence to the principles of the Declaration of Helsinki and approved by the Institutional Ethical Committee.

3.2.3.1 PATIENTS WITH CKD

The aetiology of CKD was the following: Anti-neutrophil cytoplasmic antibodies (ANCA)-associated vasculitis (20 %), hypertensive nephropathy (8 %), lupus nephritis (14 %), IgA nephritis (21 %), diabetic nephropathy (4 %), membranous nephropathy (15 %), focal and segmental glomerulosclerosis or minimal change disease (11 %), amyloidosis (5 %) and other (1 %). Patients were separated into five CKD groups according to their estimated glomerular filtration rate [eGFR; Modification of Diet in Renal Disease (MDRD)], based on Kidney Dialysis Outcomes Quality Initiative (K/DOQI), as follows: stage 5 ($n = 15$; eGFR <

15 ml/min), stage 4 (n = 31; eGFR 15-30 mL/min), stage 3 (n = 42; 30-60 mL/min). Patients with CKD stage 1 and 2 were analyzed together (n = 71; GFR > 60 mL/min). History of cardiovascular disease (CVD) was taken from medical records of each patient, comprising ischemic heart disease, peripheral ischemic disease and/or cerebrovascular disease. Most patients received medications commonly used in patients with chronic kidney disease, such as diuretics; antiplatelet drugs; calcium and vitamin D supplements; statins; and antihypertensive drugs.

3.2.3.2 CONTROL GROUP

The control group consisted of 44 healthy subjects. They were not administered any special alimentary supplements at the time of the study.

3.2.3.3 SAMPLES

Fasting blood samples from each patient were collected via puncture of the cubital vein simultaneously with blood collection for routine examination. Blood count and serum concentrations of routine biochemical parameters were determined in fresh samples. For special biochemical analysis, blood was collected into tubes without anticoagulant and were centrifuged for 10 minutes at 1.450 g (4 °C). Sera were stored at -80 °C until analysis.

3.2.3.4 LABORATORY PARAMETERS

In all patients and controls MMP-2 and PAPP-A levels and other biochemical parameters were measured using methods as were described above in the text. All measurements were performed in duplicate by investigators blinded to patients' characteristics.

3.2.4 CHANGES OF MMP-2, MMP-9, PAPP-A IN PATIENTS WITH VARIOUS NEPHROPATHIES

173 subjects were studied, including 128 patients with various types of glomerular disease (GN), defined by kidney biopsy, and 45 healthy controls randomly selected from local population. All enrolled patients were in stable clinical status at the time of the study, without signs of acute infection, tumor or acute cardiac problems. Written informed consent and laboratory samples were obtained from all subjects according to ethical guidelines. The study was performed in adherence to the principles of the Declaration of Helsinki and approved by the Institutional Ethical Committee.

3.2.4.1 PATIENTS WITH VARIOUS NEPHROPATHIES

33 had IgA glomerulonephritis (IgA), 23 membranous glomerulonephritis (MN), 11 focal segmental glomerulosclerosis (FSGS), 7 minimal change nephrosis disease (MCNS), 22

lupus nephritis (LN), and 32 anti-neutrophil cytoplasmic antibody (ANCA)-associated glomerulonephritis (AAV).

About 88% of patients received ACE inhibitors and/or AR blockers. Most patients received medications commonly used in patients with chronic nephropathy, such as diuretics; antiplatelet drugs; calcium and vitamin D supplements; statins; and antihypertensive drugs.

Written informed consent and laboratory samples were obtained from all subjects according to ethical guidelines. The study was approved by the local Institutional Ethical Committee.

3.2.4.2 SAMPLES

Fasting blood samples from each patient were collected via puncture of the cubital vein simultaneously with blood collection for routine examination. All blood samples were centrifuged for 10 min at 1.450 g (4°C). Sera were stored at -80 °C until analysis.

3.2.4.3 LABORATORY PARAMETERS

In all patients and controls MMP-2, MMP-9, and PAPP-A levels and other biochemical parameters were measured using methods as were described above in the text. All measurements were performed in duplicate by investigators blinded to patients' characteristics. The eGFR was calculated using the MDRD formula [271]. We used the US NKF-DOQI classification (2002) to stratify patients with CKD into stages according to GFR.

3.2.5 EVALUATION OF PLGF, PAPP-A, SRAGE, EN-RAGE AND HMGB-1 LEVELS IN PATIENTS WITH ACUTE KIDNEY INJURY

This cross-sectional study enrolled forty AKI patients at the inception of renal replacement therapy (RRT). Forty two patients with CKD 5 at the onset of RRT, thirty one long-term HD and thirty nine age-matched healthy control subjects served for comparison. The study was performed in adherence to the principles of the Declaration of Helsinki and approved by the Institutional Ethical Committee.

3.2.5.1 PATIENTS WITH AKI

AKI was determined using the RIFLE (Risk, Injury, Failure, Loss, and End stage kidney) staging criteria for changes in the serum creatinine within one week [75]. The enrolment was performed by attending nephrologists prior to RRT initiation. Further, blood tests and physiological parameters were obtained for each patient at the time of admission to the department after inclusion but before initiation of RRT. The aetiologies of AKI were ischemia (39.8%), nephrotoxicity (22%), and multifaceted factors (38.2%). All enrolled

patients with AKI were hemodynamically stable. The patients on mechanical ventilation were not included. We included AKI patients without sepsis. Most patients received medication used in acute kidney injury including vasoactive therapy, fluid supplementation before RRT, anticoagulation, antihypertensive treatment. Eligible patients received empirical antibiotic regimens. Antibiotics were generally dosed as recommended in the corresponding package inserts. The dose of antibiotics was adjusted according to patients' conditions and creatinine clearance.

3.2.5.2 PATIENTS WITH CKD STAGE 5

Forty two patients with CKD stage 5 with glomerular filtration rate (eGFR < 15 ml/min/1.73 m²) at the onset of RRT were included. The aetiology of CKD were vasculitis (11%), chronic glomerulonephritis (23%) hypertension (19 %) and diabetes (12 %). Most patients received medications commonly used in patients with CKD, such as diuretics; antiplatelet drugs; calcium and vitamin D supplements; statins; and antihypertensive drugs.

3.2.5.3 PATIENTS WITH ESRD TREATED WITH HD

The same group of HD patients as in the first and second study was used.

3.2.5.4 CONTROL GROUP

The control group consisted of thirty nine age matched healthy subjects. They were not administered any special alimentary supplements at the time of the study.

3.2.5.5 SAMPLES

In AKI and CKD 5 groups, blood was collected prior to the first dialysis session and prior to heparin administration. In HD patients, blood was collected via puncture of the arteriovenous fistula before starting the dialysis session and prior to heparin administration. In other subjects, blood was collected after overnight fasting via puncture of the cubital vein, simultaneously with blood collection for routine control examinations.

Blood count and routine biochemical parameters were determined in fresh samples. For special biochemical analyses, blood was centrifuged for 10 min at 1,450 g, and serum was frozen at -80 °C until analysis.

3.3 STATISTICAL ANALYSIS

3.3.1 *PLGF IN PATIENTS WITH DECREASED RENAL FUNCTION*

Results are expressed as mean \pm SD. Analysis of variance, Mann-Whitney test, and *t*-test were used for evaluation of differences among groups. Associations between parameters were determined by using Pearson or Spearman correlation coefficients. All results are considered statistically significant at *p* less than 0.05. All tests were performed using InStat software (GraphPad Software, Inc., La Jolla, CA, USA, www.graphpad.com).

3.3.2 *SERUM S100A12 (EN-RAGE) LEVELS IN PATIENTS WITH DECREASED RENAL FUNCTION AND SUBCLINICAL CHRONIC INFLAMMATORY DISEASE*

Results are expressed as mean \pm SD. Analysis of variance, Mann-Whitney test, and *t*-test were used for evaluation of differences among groups. Associations between parameters were determined by using Spearman correlation coefficients. All results are considered statistically significant at *p* less than 0.05. All tests were performed using InStat software (GraphPad Software, Inc., La Jolla, CA, USA, www.graphpad.com).

3.3.3 *DETERMINANTS OF CIRCULATING MMP-2 AND PAPP-A IN PATIENTS WITH CHRONIC KIDNEY DISEASE*

Statistical analyses were performed using Statistics Toolbox™ MATLAB® software (The MathWorks™, Inc., Natick, Massachusetts, USA, www.mathworks.com). Data are presented as the mean \pm SD for continuous variables and percentages for categorical variables. Univariate comparisons of continuous variables between control subjects and renal disease patients were conducted with unpaired sample *t*-tests; and ANOVA with post tests for normally distributed continuous variables. Mann-Whitney U test and Kruskal-Wallis ANOVA with Tukey's post tests for non-normal distributions was used to compare continuous variables between control subjects and renal patients subgrouped by four quartiles of eGFR (CKD stage). Variables with non-normal distributions were log-transformed where appropriate. Association among analyzed parameters was assessed using Spearman's or Pearson's correlation coefficient. Stepwise multivariate regression analysis was used to assess independent predictors of studied biomarkers. All results were considered statistically significant at *p* less than 0.05.

3.3.4 CHANGES OF MMP-2, MMP-9, PAPP-A IN PATIENTS WITH VARIOUS NEPHROPATHIES

Statistical analyses were performed using Statistics Toolbox™ MATLAB® software (The MathWorks™, Inc., Natick, Massachusetts, USA, www.mathworks.com). Data are presented as the mean ± SD for continuous variables and percentages for categorical variables. Comparisons between groups were conducted with unpaired sample t-tests and ANOVA for normally distributed continuous variables and Mann-Whitney U test and Kruskal-Wallis ANOVA for non-normal distributions. Variables with non-normal distributions were log-transformed where appropriate. Association among analyzed parameters was assessed using Spearman's or Pearson's correlation coefficient. All results were considered statistically significant at p less than 0.05.

3.3.5 EVALUATION OF PLGF, PAPP-A, SRAGE, EN-RAGE AND HMGB-1 LEVELS IN PATIENTS WITH ACUTE KIDNEY INJURY

Statistical analyses were performed using Statistics Toolbox™ MATLAB® software (The MathWorks™, Inc., Natick, Massachusetts, USA, www.mathworks.com). Data are presented as the mean ± SD for continuous variables and percentages for categorical variables. Univariate comparisons of continuous variables between control subjects and renal disease patients were conducted with unpaired sample t-tests; and ANOVA with post tests for normally distributed continuous variables. Mann-Whitney U test and Kruskal-Wallis ANOVA with Tukey-Kramer or Dunn's post tests for non-normal distributions was used to compare continuous variables between control subjects and renal patients. Variables with non-normal distributions were log-transformed where appropriate. Association among analyzed parameters was assessed using Spearman's or Pearson's correlation coefficient. Stepwise multivariate regression analysis was used to assess independent predictors of studied biomarkers. All results were considered statistically significant at p less than 0.05.

4 RESULTS

4.1 ELEVATION OF PLGF IN PATIENTS WITH DECREASED RENAL FUNCTION

Detailed characteristics of patients and controls are listed in Table 3.

TABLE 3 CLINICAL AND LABORATORY DATA OF CONTROL SUBJECTS AND PATIENTS WITH DECREASED RENAL FUNCTION

Parameter	HD patients	CHRI patients	Control subjects
Number of patients (men/women)	31 (15/16)	45 (28/17)	38 (16/12)
Age, years	59±16	61±15	57±8
Hypertension, n	29	43	0
History of cardiovascular disease, n	13	12	0
Diabetes mellitus, n	8	14	0
Dyslipidemia, n	16	29	0
BMI, kg/m ²	24.4±4.1	27.2±5.1	25.7±3.4
Cholesterol, mmol/L	4.2±1.01	4.6±1.0	5.3±0.6
HDL chol., mmol/L	1.1±0.4	1.2±0.3	1.7±0.3
LDL chol., mmol/L	2.4±1.0	2.6±0.9	3.0±0.5
Triglycerides, mmol/L	2.0±1.1	2.1±1.3	1.4±0.8
Haemoglobin, g/L	108±10	119±14	141±9
CRP, mg/L	10.9±11.2	7.5±1.3	4.4±3.2
Albumin g/L	40.7±3.3	41.6±4.8	44.6±3.0

Data expressed as mean ± SD.

Abbreviations: BMI – body mass index, CRP – C-reactive protein, CHRI – chronic renal insufficiency, HD – haemodialysis, HDL – high density lipoprotein, LDL – low density lipoprotein, SD – standard deviation

PIGF levels were significantly elevated in both CHRI and HD groups compared to healthy subjects, without significant differences between CHRI and HD patients (10.5±3.3 pg/mL in CHRI patients and 11.5±3.4 pg/mL in HD patients versus 8.1±1.8 pg/mL in controls; both $p < 0.0001$ versus controls; Fig 7).

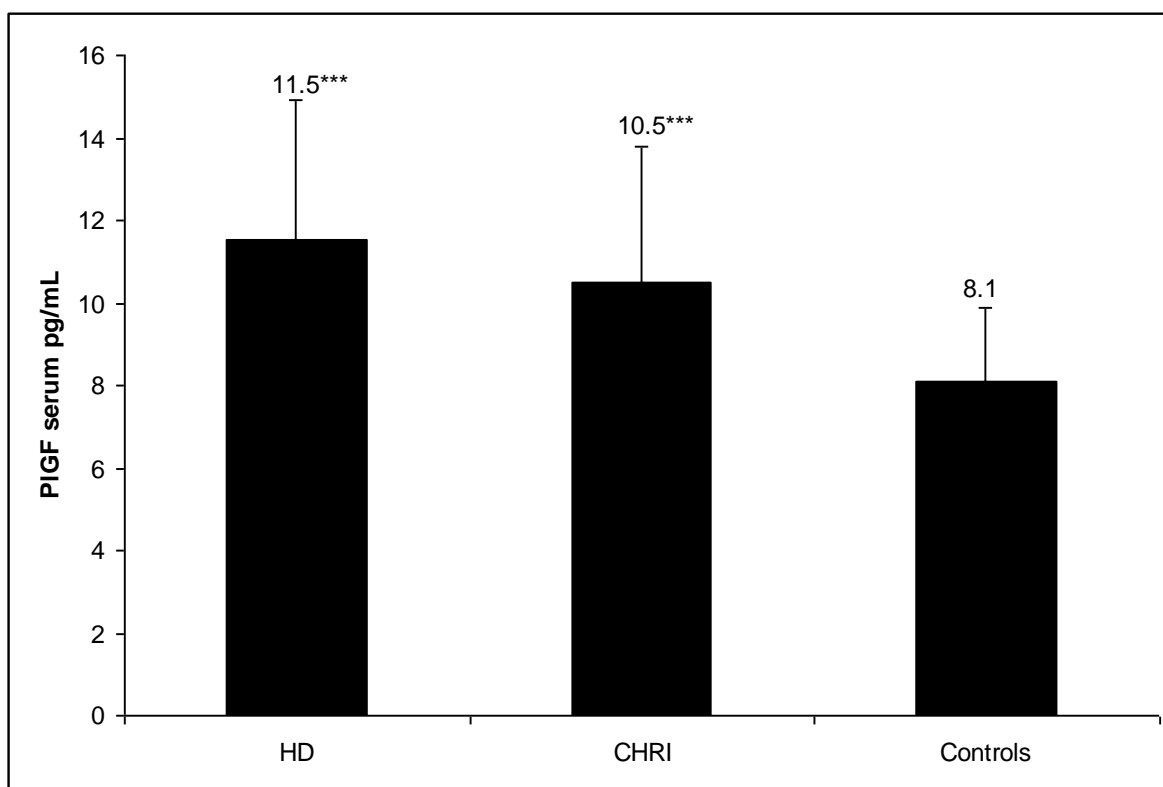

FIG. 7 SERUM PLGF LEVELS IN PATIENTS WITH CHRONIC KIDNEY DISEASE AND VARIOUS DEGREES OF DECREASED RENAL FUNCTION (CHRI, HD PATIENTS, AND HEALTHY SUBJECTS).

Results expressed as mean \pm SD. *** $p < 0.0001$, HD and CHRI versus controls.

Even in a subgroup of 16 patients with mild and marked renal insufficiency, mean GFR 54 ± 24 mL/min/ 1.73 m², PIGF was elevated when compared to control subjects (9.9 ± 2.8 pg/mL versus 8.1 ± 1.8 pg/mL, $p < 0.002$). Concerning HD patients, no difference of serum PIGF levels between patients using low flux ($n=21$) and high flux ($n=10$) membranes was shown (11.3 ± 2.9 vs. 12.1 ± 2.9 , n.s).

In 15 of 19 patients with nephropathy PIGF was detectable in urine samples (mean 5.8 ± 5.4 pg/mL) and correlated with its serum levels $r=0.45$, $p < 0.05$, Fig. 8. No relationship between PIGF and serum creatinine concentrations was found in CHRI patients. In CHRI patients the negative correlation of PIGF with diuresis ($r=-0.28$) was of borderline significance ($p=0.06$). In HD patients the negative correlation between serum PIGF levels and residual diuresis was not significant ($r=-0.43$, $p=0.18$). There was no correlation of serum PIGF to proteinuria in CHRI patients.

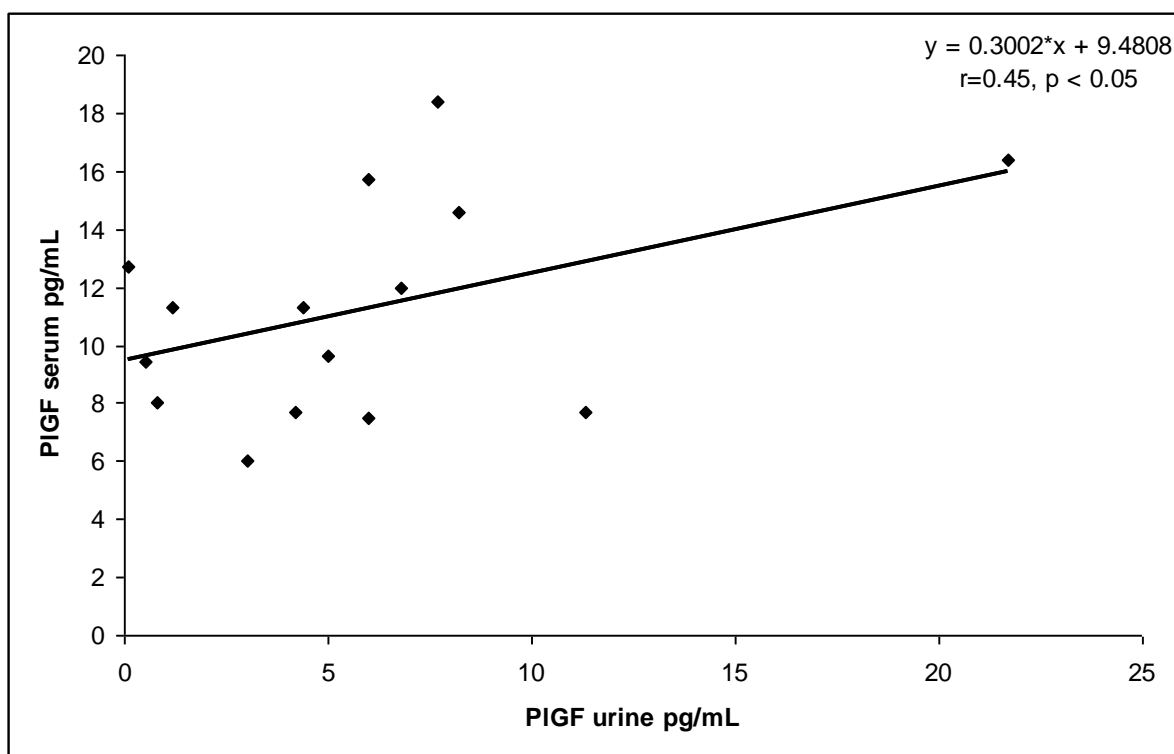

FIG. 8 CORRELATION OF SERUM PLGF LEVELS AND THEIR DETECTABLE IN THE URINE PLGF LEVELS IN CKD PATIENTS

Higher levels of PIGF were found in CHRI patients with CVD, compared to those free of such complication (12.1 ± 3 pg/mL versus 10.0 ± 3.2 pg/mL, $p=0.03$). The differences of PIGF in HD patients with CVD and those HD patients without this complication were not significant (11.8 ± 2.3 pg/mL versus 11.2 ± 4.0 pg/mL, $p=0.48$).

No difference in serum PIGF levels was observed between patients with DM and those without DM in both CHRI patients (10.1 ± 3.5 pg/mL versus 11.4 ± 2.4 pg/mL, $p=0.15$) and HD patients (12.5 ± 2.5 pg/mL versus 11.1 ± 3.6 pg/mL, $p=0.23$).

We found that PIGF in CHRI group correlated significantly with triglyceride concentrations ($r=0.32$, $p < 0.05$), and in HD group correlated significantly with low density lipoprotein concentrations ($r=0.36$, $p < 0.05$). In addition serum levels of PIGF were not significantly different among patients with dyslipidemia treated with statins and those without this treatment in both CHRI and HD groups. PIGF also correlated with age in CHRI group ($r=0.35$, $p=0.02$), correlations in controls ($r=0.30$) was of borderline significance ($p=0.06$). PIGF was not associated with CRP levels in any of the studied groups.

In summary, PIGF levels are increased in patients with renal impairment with decreased renal function including haemodialysis patients. The increase could have been

demonstrated even in the subgroup of patients with mild and marked renal insufficiency. PIGF is also present in the urine, and serum and urine concentrations of PIGF are significantly interrelated. It is higher in CKD patients with cardiovascular disease. In HD patients PIGF levels are related to LDL cholesterol concentrations as a risk marker of atherosclerosis, but not to CRP as an inflammatory marker.

4.2 LEVELS OF EN-RAGE IN PATIENTS WITH DECREASED RENAL FUNCTION AND SUBCLINICAL CHRONIC INFLAMMATORY DISEASE

Detailed characteristics of patients and controls are listed in Table 4. S100A12 levels were not different in CHRI and HD patients compared to controls (166 ± 140 ng/mL in CHRI patients and 127 ± 101 ng/mL HD patients versus 126 ± 106 ng/mL in controls, $p=0.27$, non significant). Comparing patients with higher and lower CRP levels, higher levels of S100A12 were found in patients with higher CRP values in both studied groups: HD patients (174 ± 125 ng/mL, $n=15$ versus 84 ± 43 ng/mL, $n=16$, $p=0.03$) and CHRI patients (237 ± 178 ng/mL, $n=17$ versus 124 ± 94 ng/mL $n=29$, $p=0.02$).

Hence, no relationship between S100A12 and serum creatinine concentrations was found in CKD patients. In 17 of 19 patients with nephropathy S100A12 was detectable in urine samples (mean 453.1 ± 445.6 ng/mL) and correlated with serum creatinine levels $r=0.53$, $p=0.03$. No correlation with proteinuria was observed.

Because the age difference between controls and the studied group of patients with decreased renal function could bias the results, we analyzed a subgroup of subjects comparable in age: 48 ± 12 years, in 17 HD patients and 49 ± 12 years in 24 CHRI patients versus 43 ± 9 years in 24 controls, $p=0.14$. In this subgroup as in the whole population, S100A12 values were not different (174 ± 158 ng/mL in CHRI patients and 99 ± 73 ng/mL HD patients versus 126 ± 106 ng/mL in controls, $p=0.13$).

No difference in serum S100A12 levels was observed between patients with DM and those without DM in CHRI patients (157.13 ± 123.85 ng/mL versus 169.87 ± 149.28 ng/mL, $p=0.78$, non-significant). In HD patients there was a trend of higher S100A12 levels in patients with DM than those without DM (182.86 ± 136.68 ng/mL and 108.15 ± 81.80 ng/mL, $p=0.07$ was of borderline significance).

TABLE 4 CLINICAL AND LABORATORY DATA OF CONTROL SUBJECTS AND PATIENTS WITH DECREASED RENAL FUNCTION

Parameter	HD patients	CHRI patients	Control subjects	p:Anova
Number of patients (M/F)	31 (15/16)	46 (29/17)	24 (19/5)	
Age, years	59±16	60±16	43±9	<0.0001
Hypertension, <i>n</i>	29	43	0	
History of cardiovascular disease, <i>n</i>	13	12	0	
Diabetes mellitus, <i>n</i>	8	14	0	
Dyslipidemia, <i>n</i>	16	29	0	
BMI, kg/m ²	24.4±4.1	26.9±5.0	25.6±3.4	0.04
Cholesterol, mmol/L	4.2±1.01	4.6±1.0	5.3±1.1	0.002
HDL chol., mmol/L	1.1±0.4	1.2±0.3	1.4±0.3	<0.0001
LDL chol., mmol/L	2.4±1.0	2.6±0.9	3.2±0.9	0.02
Triglycerides, mmol/L	2.0±1.1	2.4±0.4	1.5±0.8	0.05
Albumin, g/L	40.7±3.3	41.4±4.9	48.5±2.7	<0.0001
CRP, mg/L	10.9±11.2	7.3±8.2	6.1±2.4	0.12
Orosomuroid, g/L	1.0±0.4	1.2±0.5	n.a (Reference range: 0.50 to 1.20)	0.21†
α2-Macroglobulin g/L	2.0±0.8	2.1±0.7	n.a (Reference range: 1.3 to 3.0)	0.51†
Fibrinogen g/L	4.8±1.5	4.7±1.4	n.a (Reference range: 2 to 4)	0.70†
Haemoglobin, g/L	108±10	119±14	144±8	0.0001
Leukocytes (×10 ⁹)/L	7.5±2.5	7.9±2.3	5.9±1.3	0.001
S100A12 (EN-RAGE) ng/mL	127±101	166±140	126±106	0.27
sRAGE pg/mL	2.1747±1.239	2.271±1.104	850±275	0.0001
S100A12/sRAGE ratio	0.06±0.06	0.09±0.09	0.21±0.25	0.008

Data expressed as mean±SD; † – *t*-test

Abbreviations: BMI – body mass index, CRP – C-reactive protein, CHRI – chronic renal insufficiency, S100A12 (EN-RAGE) – extracellular newly identified RAGE-binding protein, HD – haemodialysis, HDL – high density lipoprotein, LDL – low density lipoprotein, SD – standard deviation, n.a. – non assessed

In CHRI patients, S100A12 correlated with C-reactive protein (CRP) levels ($r=0.46$, $p=0.001$), orosomuroid ($r=0.35$, $p=0.02$), and inversely with α-2-macroglobulin ($r=-0.3$, $p=0.04$). Correlations with leukocyte count were of borderline significance ($r=0.26$, $p=0.07$).

In HD patients, S100A12 correlated with age ($r=0.42$, $p=0.02$), CRP ($r=0.56$, $p=0.001$), orosomucoid ($r=0.4$, $p=0.04$), fibrinogen ($r=0.54$, $p=0.002$), and leukocyte count ($r=0.60$, $p=0.0004$). S100A12 was not correlated with CRP ($r=0.03$, $p=0.9$) and leukocyte count ($r=0.24$, $p=0.25$) in control subjects.

We found that S100A12 was not correlated with triglyceride concentrations, cholesterol or lipoprotein concentrations in both CHRI and HD groups. In addition serum levels of S100A12 were not significantly different among patients with dyslipidemia treated with statins and those without this treatment in both CHRI (170 ± 122 ng/mL versus 152 ± 164 ng/mL, $p=0.4$) and HD (137 ± 123 ng/mL versus 113 ± 70 ng/mL, $p=0.9$) groups.

In addition, serum levels of S100A12 were not significantly different among patients treated with angiotensin converting enzyme inhibitors or sartans (ACEI/ABR) and those without this treatment in both CHRI (168 ± 154 ng/mL, $n = 34$, vs. 159 ± 98 ng/mL, $n = 12$, $p = 0.6$) and HD (148 ± 121 ng/mL, $n = 16$, vs. 105 ± 73 ng/mL, $n = 15$, $p = 0.3$) groups.

We performed a stepwise multivariate regression analysis of contributing factors to explain S100A12 levels in all studies groups. Table 5 shows the results of stepwise multivariate analysis after adjustment for age of factors predicting S100A12 levels: orosomucoid in CHRI patients; CRP, leukocyte count, fibrinogen and negatively sRAGE in HD patients, and leukocyte count in healthy controls.

TABLE 5 FACTORS ASSOCIATED WITH S100A12 (EN-RAGE) IN ALL STUDIED GROUPS

Studied group with independent variables	B-coefficient	SE	t	p	Intercept	R ²
Controls: leukocytes	36.78	15.37	2.39	0.025	-90.30	0.20
CHRI: orosomucoid	108.927	41.18	2.64	0.0112	35.30	0.1372
HD: leukocytes	12.64	4.81	2.62	0.014	-11.89	0.756
fibrinogen	18.29	7.69	2.37	0.025		
CRP	3.75	0.66	5.66	<0.0001		
sRAGE	-0.0033	0.0088	-3.84	<0.001		

Abbreviations: B, beta coefficient, SE, standard error; t, *t*-test statistic; R², coefficient of determination, CRP – C-reactive protein, CHRI – chronic renal insufficiency, sRAGE – soluble receptor for advanced glycation end products

In summary, S100A12 levels were not elevated in CKD and HD patients compared to controls. Nevertheless in a subgroup of patients with higher CRP levels in contrast to the whole population, S100A12 values were increased in both CHRI and HD patients. In CKD patients not yet dialyzed S100A12 levels were related to orosomucoid as an inflammatory marker. In HD patients S100A12 levels also correlated to markers of inflammation such as CRP, leukocyte count, fibrinogen and negatively to sRAGE. In healthy controls, S100A12 levels were related to leukocyte count.

These results suggest that serum S100A12 levels are regulated by factors related to subclinical inflammation in patients with CKD. S100A12 is also present in the urine, and urine concentrations are higher compared to serum levels and correlate with serum creatinine.

4.3 BIOCHEMICAL DETERMINANTS OF PAPP-A AND MMP-2 IN PATIENTS WITH CHRONIC KIDNEY DISEASE

The baseline clinical characteristics of the subjects are summarized in Table 6. Mean serum MMP-2 concentrations at different stages of CKD were 228 ± 99 ng/mL. Compared with healthy controls, CKD patients (3-5) had no significant changes in MMP-2 levels. MMP-2 levels (195 ± 76 versus 255 ± 77 ng/mL, $p < 0.0001$) were significantly lower in CKD patients 1-2.

Mean serum PAPP-A levels at different stages of CKD were 10.3 ± 7.5 mIU/L. From CKD 4 we noted an increase in PAPP-A levels (12.1 ± 8.5 versus 9.3 ± 2.2 mIU/L $p = 0.001$).

Parameters statistically and significantly related to MMP-2 levels were age ($r = 0.42$, $p < 0.0001$), PAPP-A ($r = 0.51$, $p < 0.001$), cholesterol ($r = 0.35$, $p < 0.001$), fibrinogen ($r = 0.2$, $p = 0.012$), creatinine ($r = 0.34$, $p < 0.0001$), α -2-macroglobulin ($r = 0.41$, $p < 0.0001$), and proteinuria ($r = 0.52$, $p < 0.0001$) (Fig. 9); whereas eGFR ($r = -0.38$, $p < 0.0001$), haemoglobin ($r = -0.33$, $p < 0.001$), and albumin ($r = -0.54$, $p < 0.001$) (Fig. 10) were inversely related.

TABLE 6 CLINICAL, DEMOGRAPHIC AND LABORATORY CHARACTERISTICS OF THE STUDY GROUP AND CONTROLS

Variable	Controls	CKD 1 - 5	CKD 1 + 2	CKD 3	CKD 4	CKD 5	p: ANOVA for CKD subgroups and controls
Number of patients	44	159	71	42	31	15	
Age (years)	57±10	49±17	40±15	54±16	59±12	58±11	<0.001
M/F %	36/64	53/47	58/42	36/64	61/39	53/47	
Smoking %	29	13	16	9	13	7	0.71
BMI (kg/m ²)	25.5±3.5	26.8±4.4	25.8±4.2	26.9±4.4	28.7±4.8	27.6±3.9	0.02
Hypertension %	0	73	58	81	87	100	0.0003
History of CVD %	0	19	3	24	42	40	<0.0001
DM %	0	14	1	21	29	27	0.0004
MDRD (mL/min)	71 ± 11	55 ± 33	86 ± 22	44 ± 9.2	21.5 ± 3.6	11.8 ± 1.9	< 0.0001
Proteinuria (g/24h)	0.0022±0.0004	3.30±5.20	2.60±3.20	3.00±4.00	5.70±9.30	2.9 ±3.0	< 0.0001
Creatinin (umol/L)	86±12	160±110	85±19	135±27	256±64	429±87	< 0.0001
Albumin (g/L)	43.7±2.4	31.9±8.0	32.3±8.8	31.8±8.0	31.0±7.6	31.8±5.4	< 0.0001
Prealbumin (g/L)	0.27±0.02	0.27±0.08	0.26±0.07	0.26±0.08	0.29±0.10	0.29±0.08	0.22
CRP (mg/L)	3.3±2.0	6.4±7.9	4.8±4.7	7.0±11.0	7.6±7.2	7.9 ±9.3	0.02
Orosomuroid (g/L)	0.78±0.19	1.10±0.50	0.91±0.43	1.25±0.56	1.24±0.44	1.33 ±0.44	< 0.0001
Cholesterol (mmol/L)	5.43±0.85	5.9±2.2	6.0±2.1	5.9±2.2	5.8±2.2	5.0±2.3	0.31
Fibrinogen (g/L)	3.3±0.5	4.3±1.0	4.3±0.9	4.3±1.3	4.5±0.97	4.52±0.82	< 0.0001
Haemoglobin (g/L)	141±10	118±20	131±17	113±19	103±13	101 ±9	< 0.0001
α-2-Macroglobulin (g/L)	2.1 ± 0.6	2.4 ± 1.0	2.6 ± 1.1	2.4 ± 0.9	2.2 ± 0.8	2.3 ± 0.9	0.05
MMP-2 (ng/mL)	255 ± 77	228 ± 91	195 ± 76	231 ± 76	270 ± 99	280 ± 110	< 0.0001
PAPP-A (mIU/L)	9.3 ± 2.2	10.3 ± 7.5	8.7 ± 4.9	9.4 ± 4.5	12.1 ± 8.5	16 ± 15	0.001

Data expressed as mean ± SD and analysed using ANOVA, p for CKD subgroups 1-5 and controls.

ANOVA, analysis of variance, BMI, body mass index, CRP, C-reactive protein, CKD, chronic kidney disease, DM, diabetes mellitus, F, female, M, male, MDRD, Modification of Diet in Renal Disease, MMP-2, matrix metalloproteinase-2, PAPP-A, pregnancy-associated plasma protein-A, SD – standard deviation

We found positive correlations of PAPP-A with age ($r = 0.27$, $p = 0.009$), MMP-2 ($r = 0.51$, $p < 0.0001$), creatinine ($r = 0.33$, $p < 0.001$), α -2-macroglobulin ($r = 0.23$, $p = 0.003$), and proteinuria ($r = 0.29$, $p < 0.0001$) (Fig. 11). Albumin ($r = -0.26$, $p < 0.001$) (Fig. 12), eGFR ($r = -0.27$, $p < 0.001$), and haemoglobin ($r = -0.17$, $p = 0.04$) inversely correlated with PAPP-A.

$y = 0.1218 * x + 2.3067$, Pearson correlation coefficient $r = 0.52$, $p < 0.0001$

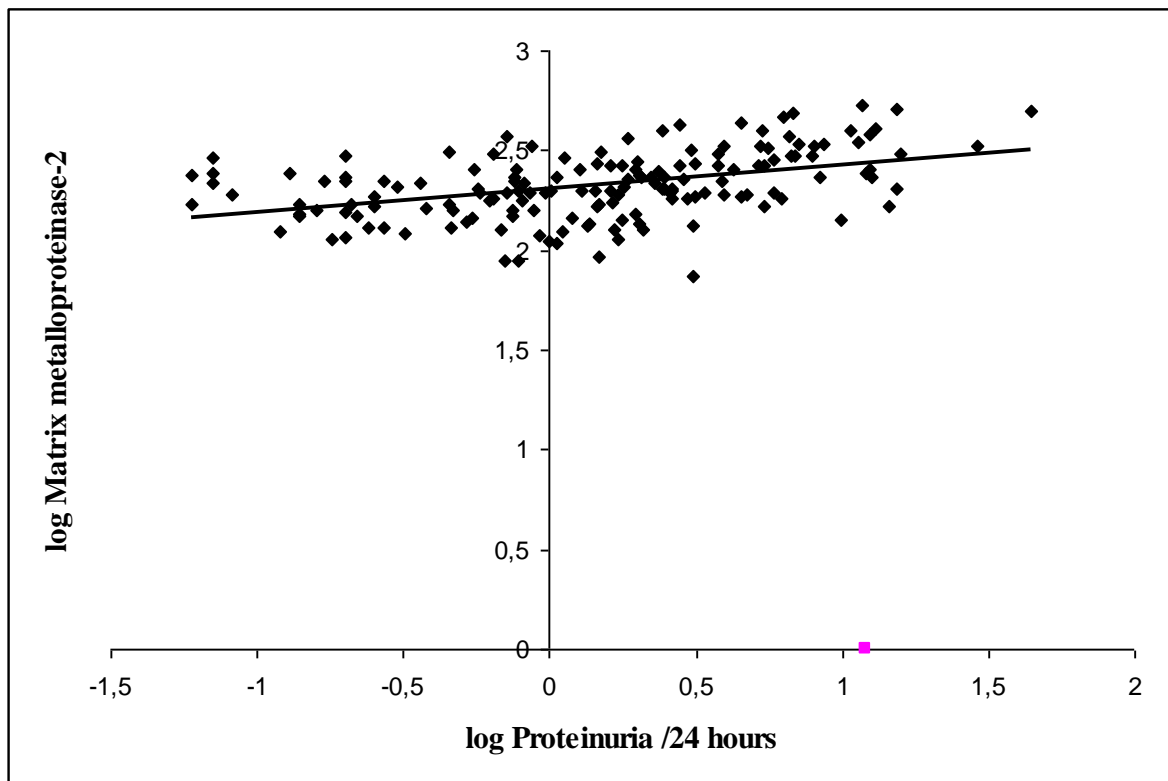

FIG. 9 CORRELATION OF LOG MMP-2 AND LOG PROTEINURIA IN CKD PATIENTS (1-5)

$y = -0.102 * x + 2.6519$, Pearson correlation coefficient $r = -0.54$, $p < 0.001$

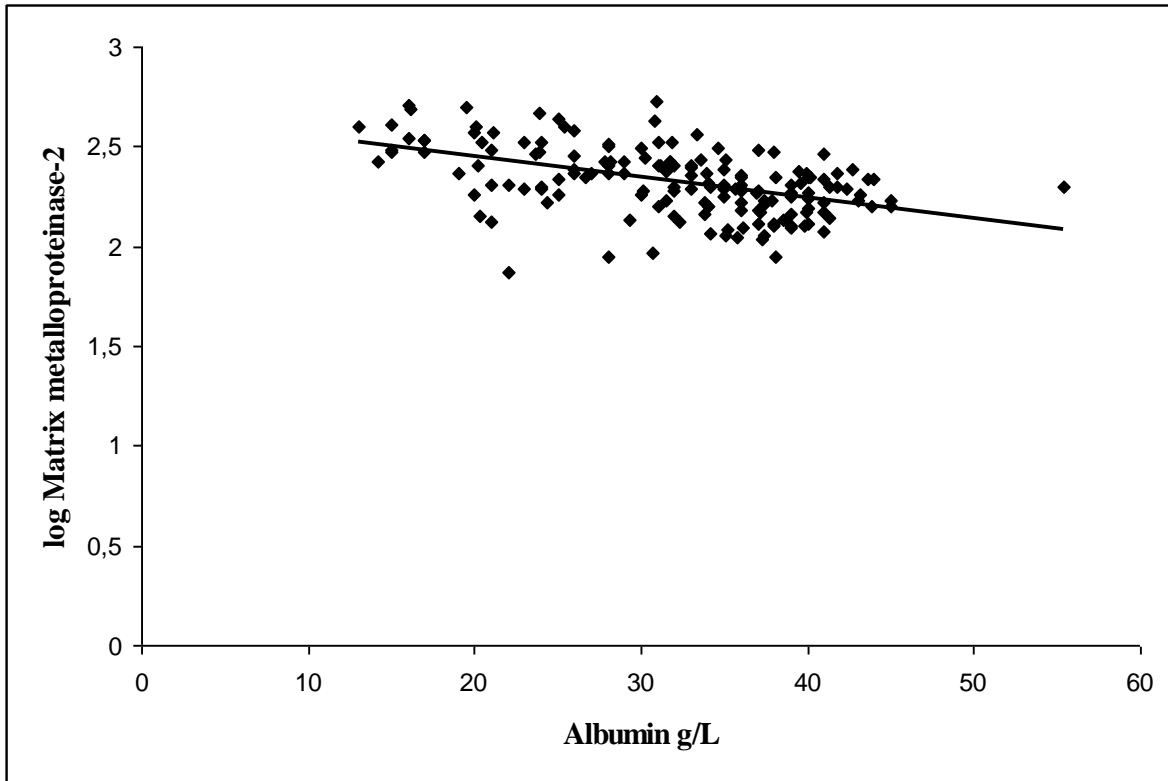

FIG. 10 CORRELATION OF LOG MMP-2 AND ALBUMIN IN CKD PATIENTS (1-5)

$y = 0.0993 * x + 0.9363$, Pearson correlation coefficient $r = 0.29$, $p < 0.0001$

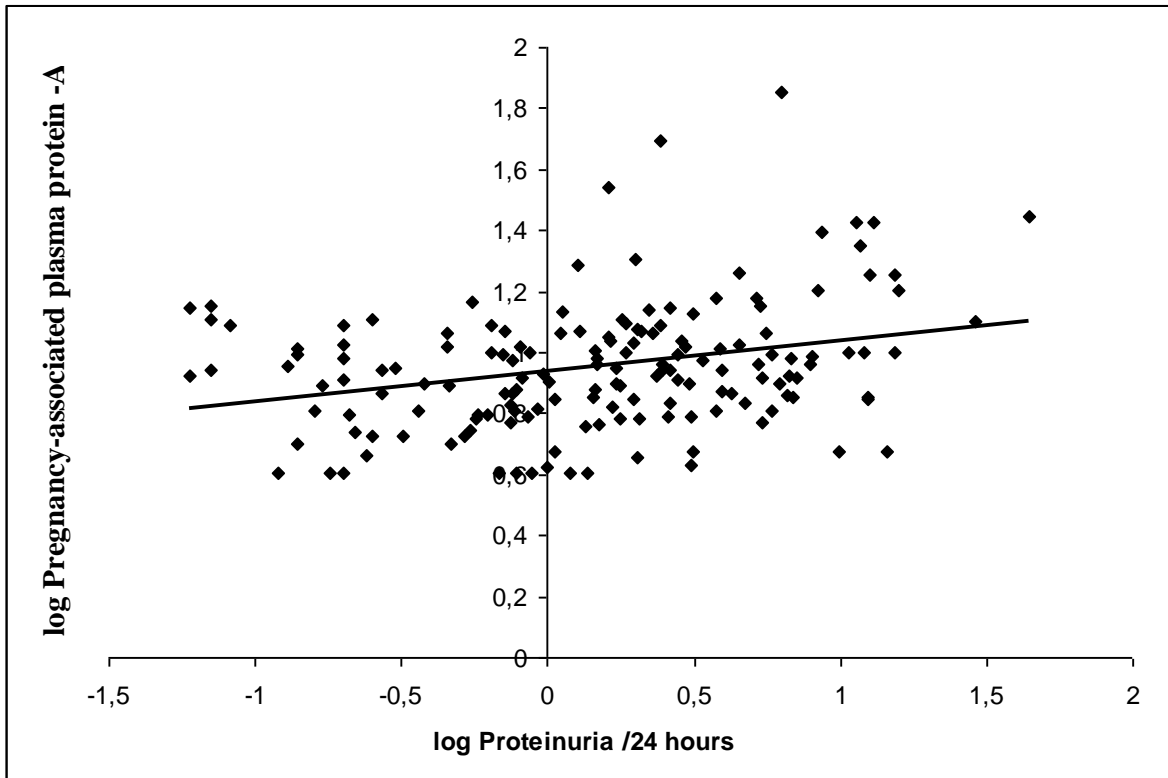

FIG. 11 CORRELATION OF LOG PAPP-A AND LOG PROTEINURIA IN CKD PATIENTS (1-5)

$$y = -0.0072 * x + 1.182, \text{ Pearson correlation coefficient } r = -0.26, p < 0.001$$

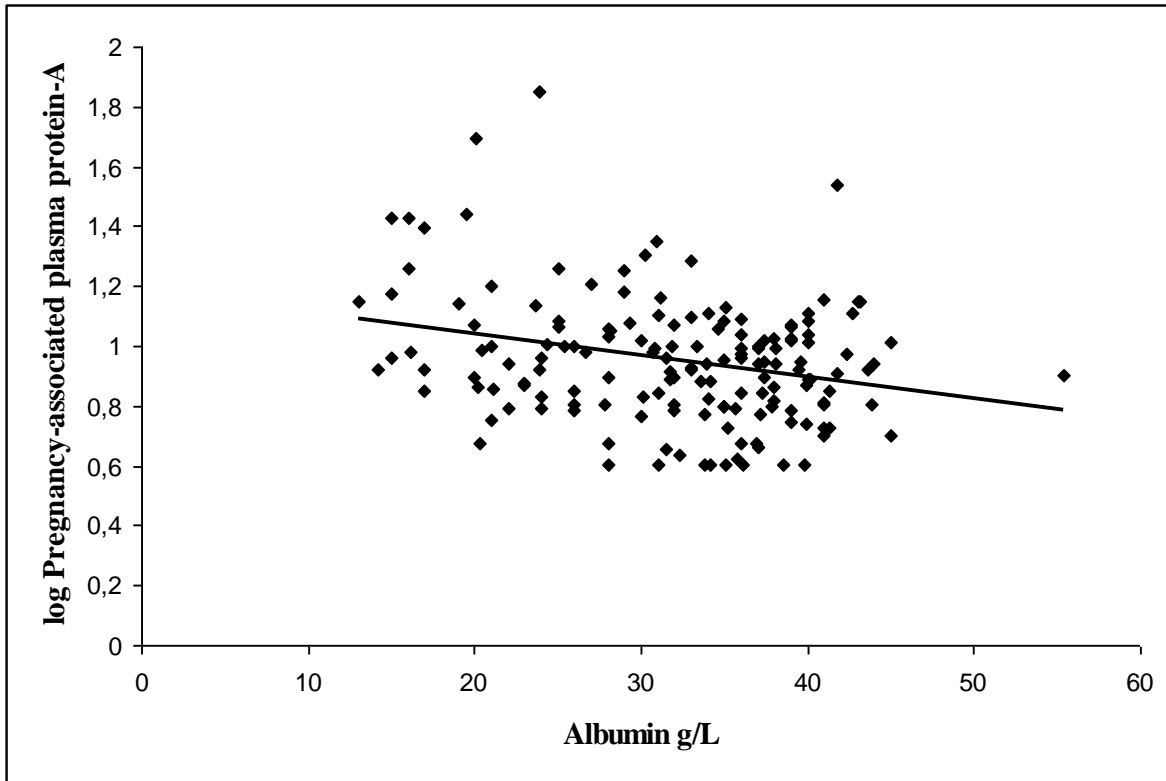

FIG. 12 CORRELATION OF LOG PAPP-A AND ALBUMIN IN CKD PATIENTS (1-5)

Because these significant parameters were closely correlated to each other, multiple regression analysis was performed. Multivariate analysis revealed that PAPP-A ($p < 0.0001$), proteinuria ($p = 0.001$), α -2-macroglobulin ($p = 0.01$), and negatively albumin ($p = 0.02$), haemoglobin ($p = 0.0002$) (Table 7) were independent correlates of MMP-2 after adjustment for age and eGFR ($R^2 = 0.45$). Proteinuria ($p = 0.02$), creatinine ($p < 0.0001$), and negatively albumin ($p = 0.01$) (Table 8) were independent correlates of PAPP-A adjusted for age and eGFR ($R^2 = 0.25$).

Taken together, circulating MMP-2 levels in CKD patients (1-5) and serum PAPP-A concentrations in CKD patients (1-3) are not elevated compared to age matched controls. Serum PAPP-A are increased from CKD 4; MMP-2 values are associated with PAPP-A, α -2-macroglobulin, proteinuria, lower haemoglobin and lower albumin in CKD (1-5) patients of various nephropathies not yet undergoing dialysis. Similarly, the determinants of PAPP-A in CKD (1-5) patients are proteinuria, serum creatinine, and lower albumin. Both MMP-2 and PAPP-A are associated with proteinuria, a significant marker of CKD and an independent risk marker for CVD as well.

TABLE 7 FACTORS ASSOCIATED WITH MMP-2. MULTIVARIATE REGRESSION ANALYSIS USING SERUM MMP-2 AS THE DEPENDENT VARIABLE (ADJUSTED TO AGE, EGFR)

Independent variables	B Coefficient	SE	T	P-Value	intercept	R^2
Albumin	-0.0036	0.0016	-2.2	0.023	2.5	0.45
PAPP-A	0.0059	0.0014	4.1	0.000047		
Haemoglobin	-0.0019	0.00052	-3.7	0.00024		
Proteinuria	0.0071	0.0021	3.2	0.0014		
α -2-Macroglobulin	0.029	0.011	2.5	0.013		

Abbreviations: B, beta coefficient, SE, standard error; T, *t*-test statistic; R^2 , coefficient of determination, PAPP-A, pregnancy-associated plasma protein-A

TABLE 8 FACTORS ASSOCIATED WITH PAPP-A. MULTIVARIATE REGRESSION ANALYSIS USING SERUM PAPP-A AS THE DEPENDENT VARIABLE (ADJUSTED TO AGE, EGFR)

Independent variables	B Coefficient	SE	T	P	intercept	R^2
Albumin	-0.005	0.0020	-2.4	0.014	0.97	0.25
Proteinuria	0.0073	0.0031	2.3	0.021		
Creatinine	0.00066	0.00012	5.1	6.8×10^{-7}		

Abbreviations: B, beta coefficient, SE, standard error; T, test statistic; R^2 , coefficient of determination

4.4 SPECIFIC CHANGES OF MMP-2, MMP-9, PAPP-A IN PATIENTS WITH CHRONIC KIDNEY DISEASE

Clinical characteristics of study population: Demographic and clinical characteristics of the subjects are summarized in Table 9. Of the 128 patients 63 were males and 65 were females. Their age ranged from 19 to 78 years. Their glomerular filtration ranged from 0.14 to 3.08 ml/s/1.73m². The male-to-female ratio was higher in IgAN group than in other groups.

The mean age was significantly lower in the LN and IgAN groups than in MN and MCNS/FSGS and AAV groups. There were not statistically significant differences in BMI, CRP, and haemoglobin when controls were compared with patients of various nephropathies (all $p > 0.05$). Baseline proteinuria was markedly lower in the LN and AAV groups than in other groups. Accordingly mean serum albumin were higher in LN and AAV groups than in other groups. No patient was nephrotic in the AAV group, and less than 5% of patients were nephrotic in LN and IgAN groups, whereas more than 20% of the patients were nephrotic in the other groups.

Serum MMP-2, MMP-9 and PAPP-A in controls and GNs: Mean serum levels of total MMP-2, total MMP-9, and PAPP-A in the six groups of chronic nephropathies and controls are shown in Table 10. Compared with controls, IgAN patients exhibited a significant decrease in serum levels of MMP-2 contrasted with increased MMP-9 and unchanged PAPP-A levels. In LN patients exhibited a parallel significant decrease in serum MMP-2, MMP-9 and PAPP-A levels. In the MCNS/FSGS group, unchanged MMP-2, MMP-9 and PAPP-A levels were observed. In MN patients, significantly increased MMP-9 levels contrasted with unchanged MMP-2 and PAPP-A levels. In AAV patients, unchanged serum levels of MMP-2, MMP-9 and PAPP-A were found (all $p < 0.05$).

TABLE 9 DEMOGRAPHIC AND CLINICAL CHARACTERISTICS OF THE SUBJECTS

Variable	Controls	IgAN	MN	MCNS	FSGS	LN	AAV	p: ANOVA Dg
Number of patients	45	33	23	7	11	22	32	
Age, years	57 ± 10	41 ± 16	56 ± 15	43 ± 20	46 ± 17	32 ± 10	55 ± 13	< 0.001
Gender (M/F sex ratio)	16 / 29	24 / 9	13 / 10	4 / 3	4 / 7	4 / 18	16 / 16	
BMI, kg/m ²	25.5 ± 3.5	26.3 ± 5.2	28.5 ± 3.3	27.1 ± 2.2	25.5 ± 4.4	24.6 ± 4.5	27.0 ± 4.6	0.11
CI _s (%)	0	9.1	65.2	42.4	36.4	45.5	84	
CS (%)	0	27.3	65.2	85.7	44.5	100	90.6	
eGFR, ml/min	71 ± 11	50 ± 34	76 ± 37	63 ± 18	74 ± 31	72 ± 27	50 ± 34	< 0.0001
Proteinuria, g/24h	0.002 ± 0.0004	3.0 ± 5.4	4.6 ± 4.9	7.4 ± 5.7	4.0 ± 4.0	1.5 ± 1.9	1.1 ± 1.2	< 0.001
Creatinine, umol/l,	86 ± 12	200 ± 140	99 ± 59	110 ± 21	99 ± 42	103 ± 46	190 ± 100	< 0.0001
Albumin, g/l	43.7 ± 2.4	34.6 ± 6.1	27.7 ± 6.7	34.6 ± 6.1	2.9 ± 1.2	33.3 ± 5.4	35.3 ± 5.0	< 0.0001
CRP, mg/l	3.3 ± 2.0	7 ± 11	4.4 ± 3.5	5.2 ± 6.5	4.1 ± 3.1	7.7 ± 8.1	7.1 ± 8.1	0.53
Haemoglobin, g/dl	14.1 ± 1.0	11.9 ± 2.1	12.5 ± 2.1	12.0 ± 2.5	12.6 ± 2.0	11.6 ± 1.8	10.9 ± 1.8	0.06
MMP-2, ng/ml	255 ± 77	183 ± 89	237 ± 61	270 ± 110	240 ± 120	183 ± 64	229 ± 64	0.006
MMP-9, ng/ml	430 ± 280	830 ± 550	800 ± 550	610 ± 360	590 ± 420	220 ± 160	570 ± 400	0.0001
PAPP-A, mIU/l	9.3 ± 2.2	8.2 ± 3.5	10.2 ± 6.4	13.1 ± 9.9	7.7 ± 1.4	7.1 ± 2.4	10.5 ± 3	0.005

Data expressed as mean ± SD.

Abbreviations: AAV – anti-neutrophil cytoplasmic antibody (ANCA)-associated glomerulonephritis, BMI – body mass index, CRP – C-reactive protein, CI_s – combined immunosuppression therapy, CS – corticosteroids, FSGS – focal segmental glomerulosclerosis, Dg – diagnosis, eGFR – estimated glomerular filtration rate, IgAN – IgA glomerulonephritis, F – female, M – male, MCNS – minimal change nephrosis disease, MN – membranous glomerulonephritis, MMP-2 – matrix metalloproteinase-2, MMP-9 – matrix metalloproteinase-9, LN – lupus nephritis, PAPP-A – pregnancy-associated plasma protein-A, SD – standard deviation

TABLE 10 BASELINE LABORATORY VALUES IN THE SIX GROUPS OF VARIOUS NEPHROPATHIES COMPARED WITH HEALTHY CONTROLS

	Controls	IgAN	MN	MCNS/ FSGS	LN	AAV
MMP-2 ng/ml, (p vs controls)	255 ± 77	183 ± 89 (0.0003)	237 ± 61(0.32)	257 ± 116 (0.95)	183 ± 64 (0.0003)	229 ± 64 (0.12)
MMP-9 ng/ml, (p vs controls)	430 ± 280	830 ± 550 (< 0.0001)	800 ± 550 (0.0005)	600 ± 391 (0.06)	220 ± 160 (0.002)	570 ± 400 (0.0.8)
PAPP-A mIU/l, (p vs controls)	9.3 ± 2.2	8.2 ± 3.5 (0.08)	10.2 ± 6.4 (0.41)	13.1 ± 9.9 (0.65)	7.1 ± 2.4 (0.0005)	10.5 ± 3 (0.06)

Data expressed as mean ± SD.

Abbreviations: AAV – anti-neutrophil cytoplasmic antibody (ANCA)-associated glomerulonephritis, FSGS – focal segmental glomerulosclerosis, IgAN – Immunoglobulin A associated glomerulonephritis, MCNS – minimal change nephrosis disease, MN – membranous glomerulonephritis, MMP-2 – matrix metalloproteinase-2, MMP-9 – matrix metalloproteinase-9, LN – lupus nephritis, PAPP-A – pregnancy-associated plasma protein-A

Relationships between serum levels of MMPs, PAPP-A and eGFR: In the IgAN groups, there was a positive correlation between serum MMP-2 and PAPP-A ($r = 0.58$, $p < 0.0001$), whereas MMP-9 did not correlate with either MMP-2 or PAPP-A. In the FSGS group, there was a positive correlation between MMP-2 and PAPP-A ($p = 0.69$, $p = 0.02$), whereas MMP-9 inversely correlated with MMP-2 ($r = -0.82$, $p = 0.002$). In the MCNS group, there was only a positive correlation between MMP-2 and PAPP-A ($r = 0.87$, $p = 0.01$). In the MN group, no correlation appeared between studied parameters. In LN group, MMP-2 correlated with PAPP-A ($r = 0.48$, $p = 0.02$). In the AAV group, there was only an inverse correlation between MMP-9 and PAPP-A ($r = -0.37$, $p = 0.04$). In all GN groups, eGFR values inversely correlated with serum MMP-2 ($r = -0.36$, $p < 0.0001$) and PAPP-A ($r = -0.32$, $p < 0.0001$) concentrations.

4.5 PLGF, PAPP-A, sRAGE, EN-RAGE AND HMGB-1 LEVELS IN PATIENTS WITH ACUTE KIDNEY INJURY

Serum PIGF, PAPP-A, sRAGE, EN-RAGE, and HMGB-1 determined from blood obtained in AKI, CKD 5, HD and control groups are displayed at Table 11.

TABLE 11 CLINICAL AND LABORATORY DATA OF CONTROL SUBJECTS, AKI, CKD 5 AND HD PATIENTS

Variable	AKI	CKD5	^a HD	Controls	pANOVA
Number of patients (M/F)	22/18	24/18	15/16	14/25	
Age, years	58±17	59±13	59±16	57±10	0.87
BMI, kg/m ²	28.3±6.7	28.6±6.9	24.3±4.1	25.2±3.4	<0.001
PIGF, pg/mL	11.7±7.4	12.3±12.4	11.5±3.8	8.5±2.4	0.02
PAPP-A, mIU/L	20.0±16.9	20.2±28.1	20.8±10.1	9.1±2.3	<0.006
sRAGE, pg/mL	2400±1400	3200±1500	2700±1200	1760±730	<0.0001
EN-RAGE, ng/mL	480±450	190±120	120±100	60±62	<0.0001
HMGB-1, ng/mL	5.8±7.5	3.2±3.1	2.5±2.1	^b 1.7±1.4	<0.0001
Blood urea nitrogen, mmol/L	29±13	27.1±7.8	26.4±7.5	4.9±1.2	<0.0001
Creatinine, µmol/L	593 ±272	520±140	800±210	86±12	<0.0001
Albumin, g/L	30.1±7.0	35.5±7.1	40.7±3.3	43.6±2.4	0.0001
Prealbumin, g/L	0.2±0.1	0.26±0.11	0.32±0.7	0.26±0.02	<0.0001
CRP, mg/L	60±70	19±22	12±16	3.2±2.1	<0.0001
Fibrinogen, g/L	5.2±1.9	5.2±1.4	4.8±1.4	3.35±0.57	0.002
Orosomuroid, g /L	1.6±0.67	1.38±0.47	1.7±0.38	0.78±0.19	<0.001
Haemoglobin, g/L	101±22	102±19	108±10	141±10	0.001
Leukocytes x10 ⁹	10.7±5.3	8.5±3.5	7.5±2.5	6.3±1.8	<0.001
Proteinuria g/ 24 hours	2.5± 3.8	2.8 ± 3.4	–	–	
Residual diuresis, L/ 24 hours	1.9 ± 1.3	1.8 ± 1.0	0.67 ± 0.70	–	<0.0001
GFR, mL/s/1.73 m ²	0.18±0.18	0.18±0.09	0.11±0.05	1.26±3.0	<0.0001

Data expressed as mean ± SD.

^a Measured in 27 control subjects.

Abbreviations: AKI – acute kidney injury, CKD5 – chronic kidney disease stage 5, BMI – body mass index, CRP – C-reactive protein, F – female, M – male, sRAGE – soluble receptor for advanced glycation end products, EN-RAGE - extracellular newly identified receptor for advanced glycation end products binding protein, HMGB-1 – high mobility group box protein-1, PAPP-A – pregnancy-associated plasma protein-A, PIGF – placental growth factor, SD – standard deviation, GFR – glomerular filtration rate

PlGF was not increased in AKI (11.7 ± 7.4 pg/mL) compared with controls (8.5 ± 2.4 pg/mL, n.s.), but was elevated ($p < 0.05$) in HD (11.5 ± 3.8 pg/mL, $p < 0.05$) versus controls (Fig. 13 Serum PlGF-A levels of AKI, CKD5, HD and control groups

).

PAPP-A was elevated in AKI (20.0 ± 16.9 mIU/L) CKD 5 (20.2 ± 28.1 mIU/L) and HD (20.8 ± 10.1 mIU/L) compared with controls (9.1 ± 2.3 mIU/L, $p < 0.001$). (Fig. 14).

sRAGE was not elevated in AKI (2400 ± 1400 pg/mL) compared with controls (1760 ± 730 pg/mL, n.s), but was lower compared with CKD 5 (3200 ± 1500 pg/mL, $p < 0.05$). sRAGE was increased in CKD 5 (3200 ± 1500 pg/mL) and HD (2700 ± 1200 pg/mL) versus controls (Fig. 15).

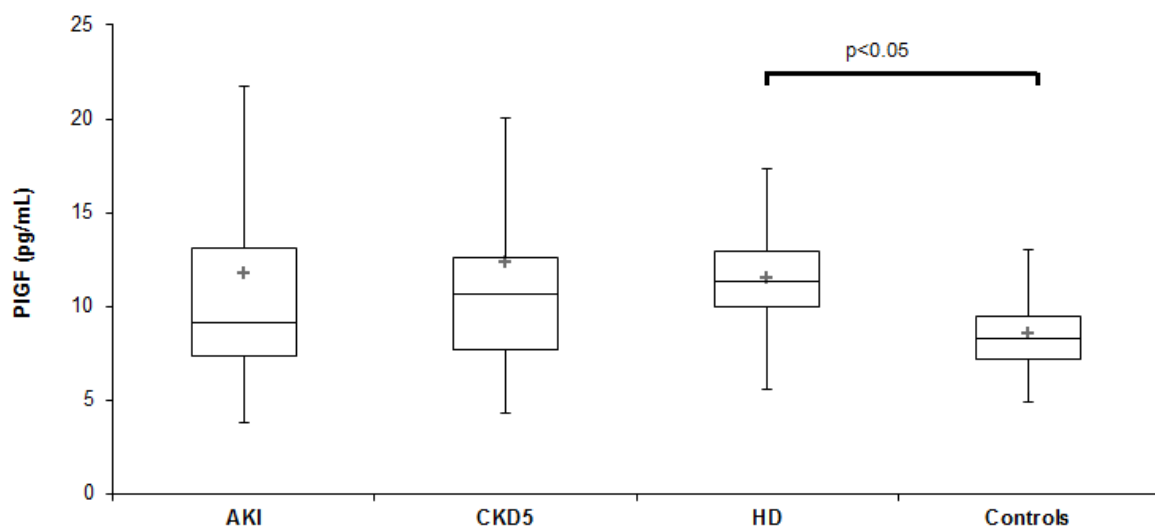

FIG. 13 SERUM PLGF-A LEVELS OF AKI, CKD5, HD AND CONTROL GROUPS

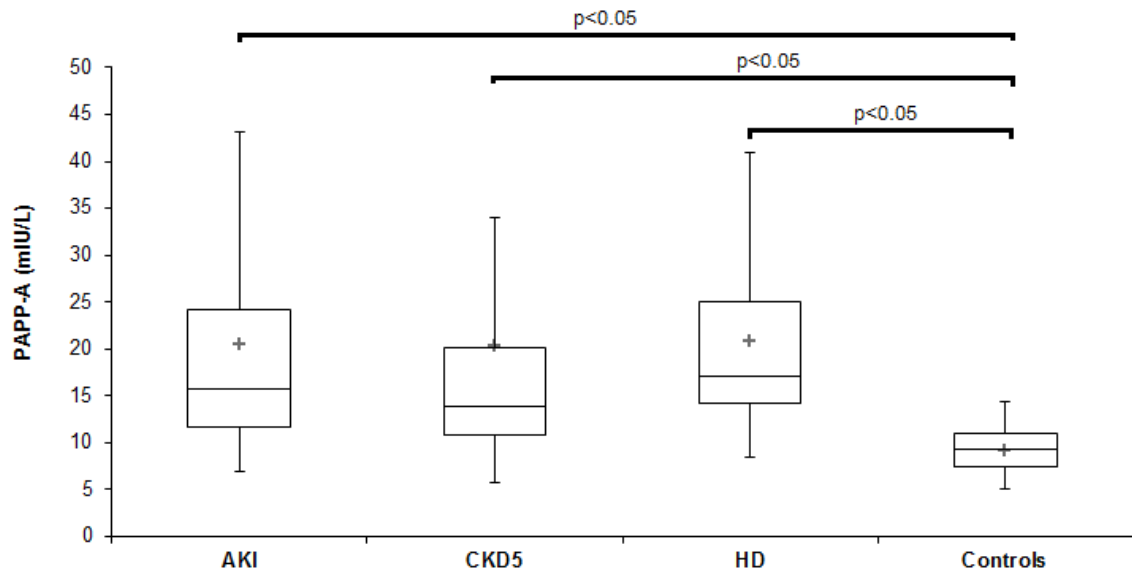

FIG. 14 SERUM PAPP-A LEVELS OF AKI, CKD5, HD AND CONTROL GROUPS

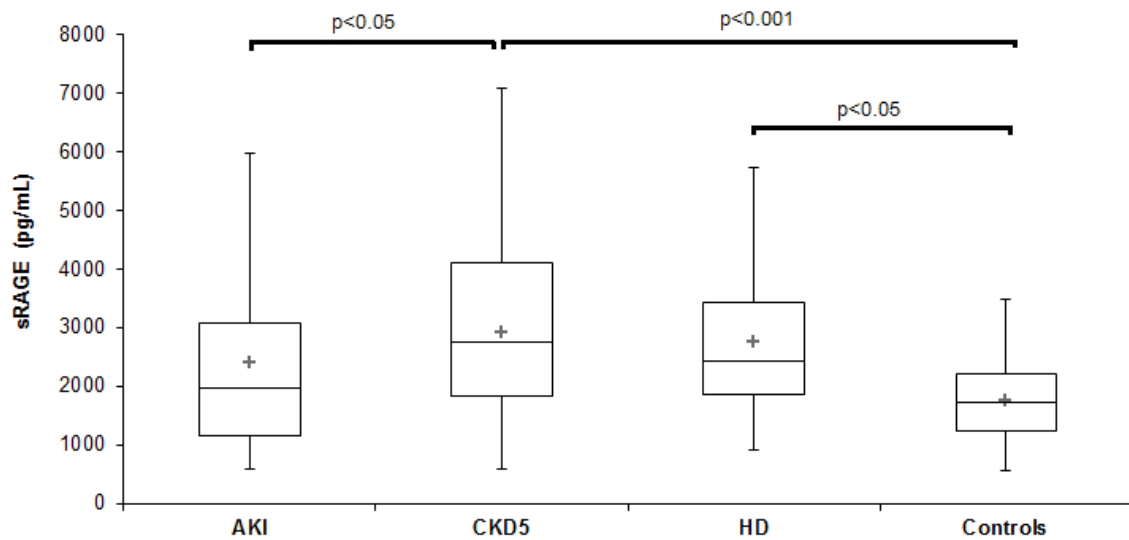

FIG. 15 SERUM SRAGE LEVELS OF AKI, CKD5, HD AND CONTROL GROUPS

EN-RAGE was elevated in AKI (480 ± 450 ng/mL) in comparison with controls (60 ± 62 ng/mL), CKD 5 (190 ± 120 ng/mL), and HD (120 ± 100 ng/mL), all $p < 0.001$ (Fig. 16).

Similarly, HMGB-1 was increased in AKI (5.8 ± 7.5 ng/mL) versus controls (1.7 ± 1.4 ng/mL), CKD 5 (3.2 ± 3.1 ng/mL) and HD (2.5 ± 2.1 ng/mL), all $p < 0.001$, as well as HMGB-1 was higher in CKD 5 and HD in comparison with controls (Fig. 17).

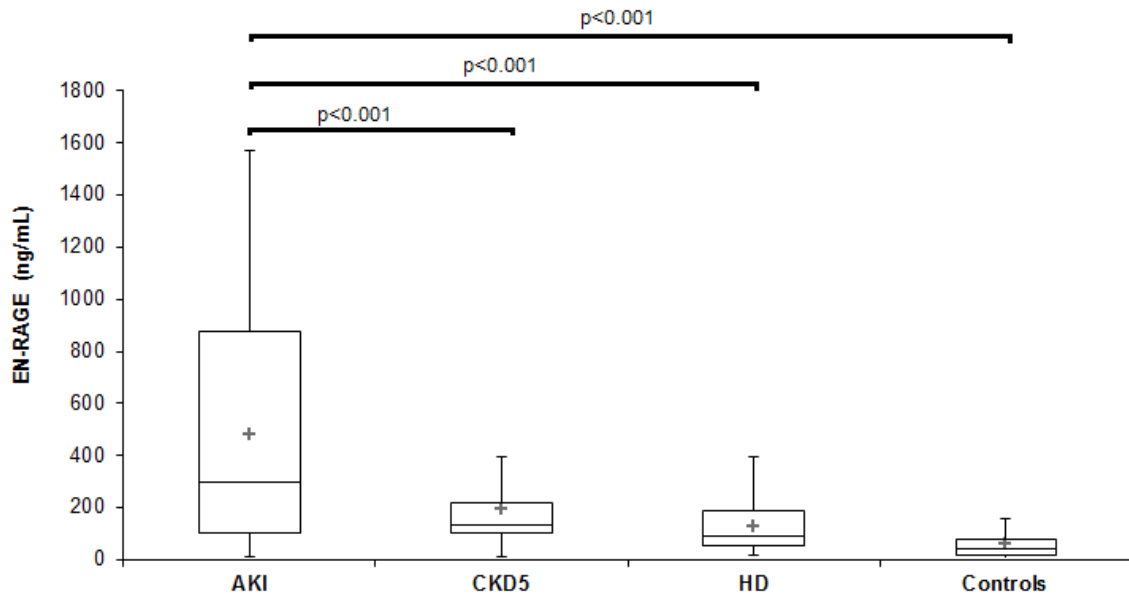

FIG. 16 SERUM SRAGE LEVELS OF AKI, CKD5, HD AND CONTROL GROUPS

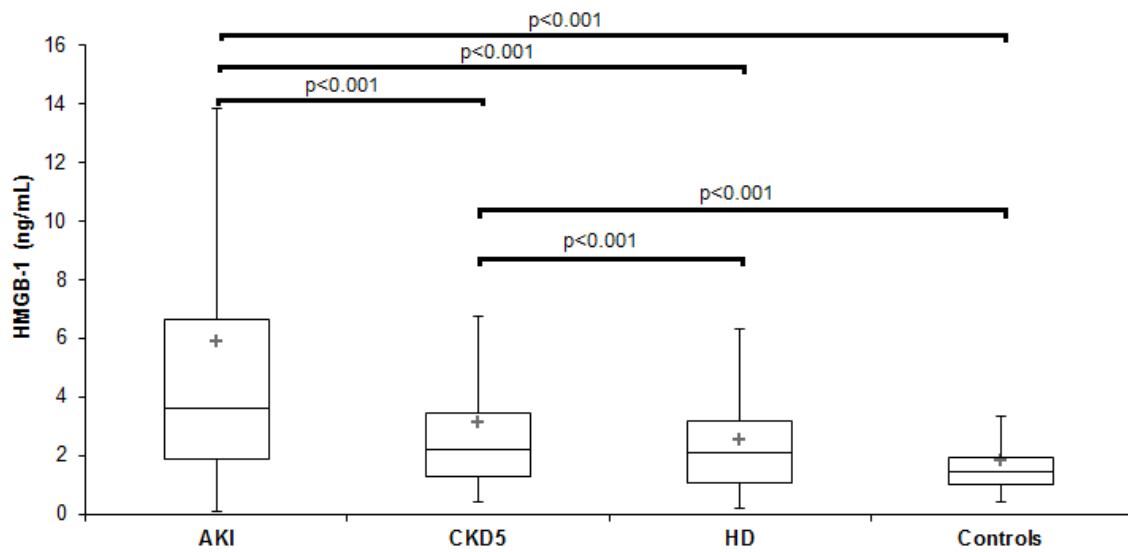

FIG. 17 SERUM LEVELS OF AKI, CKD5, HD AND CONTROL GROUPS

The results of univariate correlations between PIGF, PAPP-A, sRAGE, EN-RAGE, HMGB-1 and other variables in AKI patients and other studied groups were shown at Table 12.

TABLE 12 UNIVARIATE CORRELATIONS BETWEEN BIOMARKERS AND OTHER VARIABLES

	AKI	CKD 5	HD	Controls
PIGF	CRP, r = 0.57, p = 0.002 Fibrinogen, r = 0.47, p = 0.002 Prealbumin, r = - 0.37, p = 0.02	EN-RAGE, r = 0.34, p = 0.03	-	Age, r = - 0.41, p = 0.01
PAPP-A	Albumin r = - 0.42, p = 0.01 Transferrin, r = 0.36, p = 0.01 Prealbumin r = - 0.42, p = 0.01	Fibrinogen, r = - 0.34, p = 0.03 Serum protein, r = - 0.38, p = 0.03 BUN, r = 0.32, p = 0.03	Leucocyte count, r = - 0.34, p = 0.03 Albumin, r = - 0.038, p = 0.03 CRP, r = 0.4, p = 0.02 Cholesterol, r = 0.4, p = 0.02	Cholesterol, r = - 0.44, p = 0.01
sRAGE	Haemoglobin, r = - 0.44, p = 0.001	Leucocyte count, r = - 0.36, p = 0.03 GFR, r = - 0.32, p = 0.02	Ferritin, r = 0.43, p = 0.02	EN-RAGE, r = - 0.41, p = 0.01 GFR, r = - 0.37, p = 0.04
EN-RAGE	CRP, r = 0.36, p = 0.03 Orosomucoid, r = 0.46, p = 0.003 Ferritin, r = 0.51, p = 0.001 Leucocyte count, r = 0.51, p = 0.03 GFR, r = - 0.34, p = 0.04 BUN, r = 0.33, p = 0.03	HMGB-1, r = 0.38, p = 0.04 Age, r = - 0.44, p = 0.04	HMGB-1, r = 0.63, p = 0.001 Fibrinogen, r = 0.49, p = 0.01 CRP, r = 0.78, p = 0.001 Orosomucoid, r = 0.43, p = 0.001 Leucocyte count, r = - 0.56, p = 0.01	Prealbumin, r = 0.39, p = 0.02 GFR, r = 0.33, p = 0.04 sRAGE, r = - 0.41, p = 0.01
HMGB-1	Leucocyte count, r = 0.42, p = 0.01 Proteinuria, r = - 0.36, p = 0.02 Cholesterol, r = - 0.34, p = 0.03	Leucocyte count, r = 0.48, p = 0.001	CRP, r = 0.45, p = 0.01 Total protein, r = 0.48, p = 0.01	-

Data are expressed as mean \pm SD

Abbreviations: AKI – acute kidney injury, BUN – blood urea nitrogen, CKD5 – chronic kidney disease stage 5, CRP – C-reactive protein, sRAGE – soluble receptor for advanced glycation end products, EN-RAGE - extracellular newly identified receptor for advanced glycation end products binding protein, HMGB-1 – high mobility group box protein-1, PAPP-A – pregnancy-associated plasma protein-A, SD – standard deviation, GFR – glomerular filtration rate.

In AKI group, sRAGE levels were inversely correlated with haemoglobin ($r = -0.44$, $p = 0.001$). In multivariate regression analysis: PAPP-A levels were associated with transferrin ($p < 0.001$), negatively with albumin ($p < 0.01$) and prealbumin ($p < 0.05$); PIGF levels were associated with C - reactive protein ($p < 0.001$). EN-RAGE levels were associated with ferritin ($p < 0.01$) and orosomucoid ($p=0.02$), and HMGB-1 levels with leukocyte count ($p < 0.01$) and negatively with proteinuria ($p = 0.02$) (Table 13).

TABLE 13 ASSOCIATIONS OF PLGF, PAPP-A, EN-RAGE AND HMGB-1 LEVELS IN AKI PATIENTS (MULTIVARIATE REGRESSION ANALYSIS)

	Predictor	B Coefficient	SE	T	p	intercept	R^2
PIGF	CRP	0.0018	0.00043	4.2	0.0001	0.8	0.32
PAPP-A	Albumin	-0.0153	0.0048	-3.1	0.003	1.6	0.47
	Transferrin	0.0674	0.0174	3.8	0.0004		
	Prealbumin	-0.6379	0.3005	-2.1	0.04		
EN-RAGE	Ferritin	519.26	181.72	2.8	0.006	-955.48	0.35
	Orosomucoid	722.37	318.18	2.2	0.02		
HMGB-1	Leucocyte count	1.063	0.384	2.7	0.008	-0.537	0.28
	Proteinuria/24 hours	-0.307	0.128	-2.3	0.02		

Abbreviations: CRP – C-reactive protein, sRAGE – soluble receptor for advanced glycation end products, EN-RAGE - extracellular newly identified receptor for advanced glycation end products binding protein, HMGB-1 – high mobility group box protein-1, PAPP-A – pregnancy-associated plasma protein-A

To conclude the PAPP-A, EN-RAGE and HMGB-1 levels are significantly elevated, but sRAGE and PIGF levels are not increased in AKI patients. sRAGE has a reverse relation to haemoglobin. PAPP-A levels are independently associated with markers of nutrition: transferin and negatively with albumin and prealbumin. PIGF is associated with CRP. EN-RAGE is independently associated with inflammatory markers: ferritin and orosomucoid. HMGB-1 is associated with leukocyte count and negatively with proteinuria in AKI patients.

5 DISCUSSION

5.1 THE IMPACT OF CIRCULATING LEVELS OF PLGF, PAPP-A, MMP-2, MMP-9, SRAGE, EN-RAGE, AND HMGB-1 IN PATIENTS WITH CHRONIC KIDNEY DISEASE

Recent investigators have indicated that increase in biomarker upstream from biomarkers of inflammation, oxidative stress, nutrition, and endothelial dysfunction [26, 27, 29-31, 34, 35, 272-276] may provide earlier assessment of renal, cardiovascular and overall patient risk and aid in identifying patients with higher risk of an adverse event and poor outcome in CKD and AKI settings. Based on this, we explored whether alterations of novel biomarkers (PIGF, PAPP-A, MMP-2, MMP-9, sRAGE, EN-RAGE, and HMGB-1) would contribute to the characterization of risk profile in patients with renal disease.

5.1.1 *PLGF IN PATIENTS WITH DECREASED RENAL FUNCTION*

The first question in our study was whether serum PIGF levels were changed in patients with decreased renal function including HD patients. Furthermore, we aimed to investigate the association between PIGF and serum lipids as markers of dyslipidemia and CRP as inflammatory marker.

In this study in 45 patients with CKD with different degrees of renal insufficiency not-yet-dialyzed and 31 haemodialysis patients we noted elevated PIGF levels compared to healthy controls. The serum levels of PIGF in HD patients do not differ from those PIGF concentrations in patients with various degrees of decreased renal function not-yet-dialyzed. Additionally, this is the first study where PIGF levels were measured simultaneously in serum and urine in patients with decreased renal function. PIGF is present in the urine of patients with renal impairment and serum and urine concentrations of PIGF are significantly interrelated in patients with decreased renal function. Given that PIGF is a small dimeric protein with a molecule (≈ 50 kDa) [101], it is readily filtered into urine even in the absence of renal damage [126]. PIGF is derived entirely from the circulating blood and not from the cells of the kidney itself (glomerular podocytes and tubular cells) as urinary vascular endothelial growth factor (VEGF) [277, 278]. Although no relationship between PIGF and serum creatinine concentrations was found in CHRI patients, serum PIGF levels tended to correlate with diuresis in CHRI and HD patients.

PlGF expression increases significantly in early gestation, peaks at around 26-30 weeks and decreases as term approaches [279]. PlGF has also been used as a predictor of the common pregnancy associated hypertensive disorder preeclampsia. Plasma, serum, and urine PlGF levels decrease significantly in women with preeclampsia, and/or those who subsequently develop the disorder [125, 127, 128, 279]. Serum PlGF levels in non-pregnant subjects (both males and females) are much lower in comparison with pregnant women. PlGF-mRNA is present in very small amounts in heart, lung, thyroid, goiter, and skeletal muscle. It is not expressed, however in kidney and pancreas [110, 280].

PlGF was recently shown to be up-regulated in early and advanced atherosclerotic lesions [136, 281]. Irrespective of its potential role in the development of atherosclerosis, in the present study increased plasma PlGF levels obviously characterize patients with renal disease as a separate population when compared with normal subjects without renal and cardiac disease. In contrast, in a recent study examining the role played by soluble fms-like kinase-1 (sFlt-1), an endogenous antagonist of the proatherogenic cytokine PlGF, authors demonstrated that plasma PlGF levels were unaffected by differences in renal function. Although the PlGF/sFlt-1 ratio was negatively correlated with the eGFR, plasma PlGF levels were not affected by it [282].

In addition, our study showed higher levels of PlGF in CKD patients not-yet-dialyzed with CVD compared to those patients without CVD. This finding suggests that PlGF might be an indicator of CVD and atherosclerotic complications in patients with decreased renal function. This finding is in line with finding of Onoue et al. [282], where the PlGF/sFlt-1 ratio was significantly higher in patients with multivessel coronary artery disease than in patients with single-vessel or no coronary disease. In the animal part of the study a reduction in the circulating levels of sFlt-1 was associated with the worsening of atherosclerosis that accompanied renal dysfunction, whereas serum PlGF concentrations were higher in the 5/6-nephrectomized mice. In the peripheral circulation, free PlGF, free sFLT-1, and the PlGF-sFlt-1 complex are present simultaneously. The PlGF-sFlt-1 complex was most closely correlated with the severity of atherosclerosis in both patients with renal dysfunction and 5/6-nephrectomized mice [282].

In a cohort of 190 type 1 diabetic patients with diabetic nephropathy, elevated PlGF levels predicted higher risk of coronary heart disease after 10 years of follow-up independent of kidney function and established coronary heart disease risk biomarkers [283]. In this study,

the PIGF levels in patients with decreased renal function with DM and those patients without DM were not different. The reason might be due to the relatively small sample size of patients with DM in this study.

In the general population elevated PIGF levels showed a modest correlation between PIGF levels and triglyceride concentrations and inverse correlation with high density lipoproteins levels among women without known coronary heart disease [284]. This study suggested that elevated PIGF levels might be associated with subsequent risk of coronary heart disease. In our study we found a modest relation between plasma PIGF levels and low density lipoproteins in haemodialysis patients and triglyceride concentrations in patients with chronic kidney disease. The finding that PIGF is linked to classic risk factors of atherogenesis in our cohort of patients with decreased renal function is a novel finding suggesting that this growth factor might play a role in atherosclerosis in these patients. Furthermore, PIGF might be considered as one of the candidates to be a biomarker for accelerated atherosclerosis, particularly plaque instability, myocardial ischemia and prognosis of the patients with cardiovascular and renal disease [285].

In the present study PIGF levels in HD patients with low-flux and high-flux dialysis membranes were not different, as with larger solutes of 50 kDa the clearance by low-flux, and even high-flux, dialysis is practically nil [286]. Therefore, we can also hypothesize that PIGF is not filtered during dialysis due to the size of the protein. We can speculate that one source of increased PIGF levels in HD patients might be monocytes activation during long-term haemodialysis.

Circulating levels of VEGF and PLGF are increased in animal models of sepsis [287]. Recently the same authors suggested that up-regulation of PIGF in sepsis is an adaptive host response that exerts its benefit, at least in part, by attenuating VEGF signaling implicating that the effects of PIGF are highly context dependent. In our study there was no correlation between serum PIGF levels and CRP. Although CRP levels were slightly higher in the studied groups, PIGF levels were low; patients were in a stable clinical state. These factors might be the reason that no relationship of PIGF and CRP, a marker of microinflammation, was found.

Statins exert cardioprotective actions partly through anti-inflammatory actions in addition to their lipid lowering effects [288, 289]. Recently it was shown that atorvastatin increased plasma levels of soluble Fms-like tyrosine kinase-1 while decreasing VEGF and PIGF levels. These changes were associated with late improvement of post myocardial

infarction ventricular function and might represent an additional benefit of statin therapy [290]. Although there were no differences in PIGF levels of CHRI and HD patients with and without statin therapy in this study probably due to small sample size, the beneficial effect of lipid lowering therapy on PIGF levels cannot be excluded in patients with chronic kidney disease.

Atherosclerosis is more commonly observed in the elderly than in the young. In the general population it was shown that PIGF weakly correlated with age [284]. In the present study there was a modest correlation between serum PIGF levels and age in the CHRI group and the control group. The correlation in the control group was of borderline significance; in the HD group the correlation with age was not significant probably due to the small sample size and other possible influencing factors. Renal insufficiency and worsening of atherosclerosis is a complex process related to renal dysfunction and ageing, and many factors are still unknown.

In summary, PIGF, an endogenous cytokine, is elevated in patients with decreased renal function. This study also shows that PIGF is present in the urine, and its serum and urine levels are interrelated. It is higher in CKD patients with cardiovascular disease. This finding warrants further investigation to understand PIGF's importance in atheroma formation and plaque destabilization to determine utility as a long-risk biomarkers in patients with kidney disease.

5.1.2 SERUM S100A12 (EN-RAGE) LEVELS IN PATIENTS WITH DECREASED RENAL FUNCTION AND SUBCLINICAL CHRONIC INFLAMMATORY DISEASE

In the next study we aimed to determine S100A12 (EN-RAGE) levels and describe their relationship to inflammatory markers in patients with decreased renal function including haemodialysis patients.

This study shows that levels of S100A12 were not different in not-yet-dialyzed CKD patients with different degrees of renal insufficiency and HD patients compared to healthy controls. The patients were all in stable clinical status at the time of the study without signs of acute infection or acute cardiac problems. However, in a subgroup of patients with higher CRP levels in contrast to the whole studied population the S100A12 values were increased. Thus, we suggest that although serum S100A12 levels are not increased at basal conditions, the presence of subclinical inflammation though is likely to result in the higher levels of

S100A12 in CKD and HD patients. In addition, we detected S100A12 in the urine of CKD patients which correlated with serum creatinine, but not with serum S100A12 levels.

These results are in contrast with the finding of Mori et al. [291], where levels of S100A12 were significantly higher in HD patients with atherosclerosis. Also the same authors reported a significant increase in S100A12 concentrations in patients on continuous ambulatory peritoneal dialysis (CAPD) [292]. This discrepancy could be due to the relatively small sample size in this study and also to the heterogeneity of the study population [291]. Further studies are necessary to clarify this issue.

In line with previous reports [180, 187], our study confirms that serum sRAGE levels are elevated in patients with decreased renal function in both patients with CKD and HD patients as compared with those in healthy controls. Also the S100A12/sRAGE ratio appears to be more favorable in CKD and HD patients than in the controls. sRAGE concentrations increase with declining renal function and significantly decrease after renal transplantation [293, 294]. The precise mechanism of sRAGE increase in patients with declining renal function is still unknown, suggesting either a decreased clearance of sRAGE accompanying the decline in renal function, or its upregulation as protective factor against toxic effects of advanced glycation end products (AGEs) in patients with progressing loss of renal function [187, 200]. In HD patients, levels of sRAGE are elevated in comparison with healthy subjects, and might modulate vascular and inflammatory reaction during dialysis. Other causes such as stimulation of neutrophils on dialysis membrane, puncture of arteriovenous fistula, and heparin administration might participate in increased serum S100A12 levels in HD patients [187].

In stepwise multivariate regression analysis after adjustment for age, S100A12 remained correlated with inflammatory markers in all studied groups: orosmuroid in CHRI patients; CRP, leukocyte count, fibrinogen and inversely sRAGE in HD patients; and leukocyte count in healthy controls. It is conceivable that S100A12 might contribute to some of the risk for inflammation associated with renal impairment.

Considering the proinflammatory functions of S100A12, it is possible that neutrophil – derived S100A12 might be involved in an inflammatory process of CKD and HD patients. Correlations of serum S100A12 levels with inflammatory parameters (CRP, orosomuroid, negatively with alfa-2-macroglobulin) in CKD patients and (CRP, orosomuroid, fibrinogen, in addition to leukocyte count) in HD patients in this study support this possibility. Indeed,

S100A12 is secreted from activated neutrophils and exerts its proinflammatory effects on the endothelium and leucocytes via binding to RAGE expressed on these cells [195, 198]. Interaction of EN-RAGE (S100A12) with cellular RAGE on the endothelium, mononuclear phagocytes, and lymphocytes triggers cellular activation with generation of key proinflammatory mediators [295]. Low sRAGE and high S100A12, but not Nε-(carboxymethyl)-lysine-protein adducts (CML), were strongly associated with increased risk for cardiovascular disease (Framingham score) in diabetic and non-diabetic subjects. Thus, the inverse correlation between S100A12 and sRAGE suggests that chronic proinflammation, including atherosclerosis, may up-regulate plasma S100A12 levels, which in turn decreases plasma sRAGE levels [187]. Recently, Nakashima et al. [200] showed that S100A12 and sRAGE are elevated and have opposite associations with inflammation in prevalent HD patients.

In addition, S100A12 was also isolated, via drug-affinity chromatography, as a protein binding to three different anti-allergic drugs: amlexanox, cromolyn and tranilast [296]. It is feasible that exaggerated release of this S100A12 protein at sites of inflammation induces a positive feedback loop in which primed phagocytes and S100A12 stimulated endothelium facilitate the further recruitment of even more leukocytes [297].

In accordance with the study of Basta et al. [181], we also found a close association between hsCRP and serum S100A12 levels in CKD patients. Hasegawa et al. [298] have demonstrated that levels of mRNA/protein of S100A12 were enhanced by another pro-inflammatory molecule i.e. IL-6 in cultured THP-1 cells. S100A12 serum concentrations indicate neutrophil activation in Crohn's disease [297], juvenile rheumatoid arthritis [299], rheumatoid and psoriatic arthritis [300], cystic fibrosis [301], Kawasaki disease [302], MPO-ANCA associated glomerulonephritis [303] and type 2 diabetes [304].

Atherosclerosis has an inflammatory aetiology and elevated CRP in patients with atherosclerosis not only serves as a biomarker for cardiovascular disease risk but it also functions as an active mediator of atherosclerosis by its direct proatherogenic effects on vasculature [305, 306]. Moreover, CRP and orosomucoid were shown to be the inflammatory markers in different stages of CKD [307]. Mahajan N et al. [308] suggested that CRP is able to augment mRNA expression of both RAGE and S100A12 genes. Augmented expression of S100A12 in the presence of CRP points to close correlation between S100A12 and activation of granulocytes and monocytes under inflammatory conditions. The parallel trend observed for the increased expression of RAGE and its ligand represents an attractive model to explain

how RAGE and its proinflammatory ligand S100A12 contribute to pathophysiology of various inflammatory diseases including atherosclerosis [308]. Also orosomucoid displays several activities on one cell type: on neutrophils it influences chemotaxis, superoxide generation and aggregation [309]. Orosomucoid, being an acute-phase reactant, contributes to the general function of the acute phase response as a coordinated system that modulates host immune response during periods of intense inflammation and tissue destruction.

Although there were no differences in S100A12 levels in CHRI and HD patients with and without statin therapy in this study probably due to the small sample size, the beneficial effect of lipid lowering therapy on S100A12 levels cannot be excluded in CKD patients. Recently it was shown that atorvastatin treatment significantly attenuated CRP-induced RAGE and S100A12 expression in THP-1 cells [308], indicating the importance of anti-inflammatory properties of atorvastatin which may be mediated by non-steroidal products of the mevalonate pathway.

Angiotensin-converting enzyme 1 inhibitors are also another factor that may potentially modulate the AGE-RAGE pathway [310]. We did not observe a significant difference in S100A12 levels in relation to treatment with ACEI/ABR in our patients with decreased renal function. However, a larger cohort of patients should be tested to confirm or exclude the effect of the above mentioned drugs on S100S12 levels in this population.

This study has some limitations. First, our study was limited by its observational nature, which allowed us to establish associations, but not causality. Second, the studied groups were older than the controls. We performed the general liner regression analysis and multivariate analysis with appropriate adjustment to age. Third, because the S100A12 protein has been measured in a small sample of subjects, our data need to be confirmed in a larger cohort of patients.

In conclusion, S100A12 (EN-RAGE), a sensitive and specific marker of localized inflammatory process, is not elevated in patients with decreased renal function at stable clinical status without signs of overt inflammation. Even in these basal conditions, it is significantly related to inflammatory markers. In addition, this study also shows that S100A12 is present in the urine, and urine levels are higher in comparison with those in serum and correlate with renal function. This finding warrants further investigation to understand the importance of S100A12 in the inflammatory process, and to determine its utility as an inflammatory biomarker in patients with kidney disease.

5.1.3 BIOCHEMICAL DETERMINANTS OF PAPP-A AND MMP-2 IN PATIENTS WITH CKD

The third study evaluated whether changes in MMP-2 and PAPP-A values in CKD are measurable by serum assays, each level of CKD is associated with a specific pattern in circulating MMP-2 and PAPP-A values, and specific biochemical determinants of circulating MMP-2 and PAPP-A are detectable in CKD patients stages 1-5 of various nephropathies not yet undergoing dialysis.

Three important findings emerge from our study. First, there were not marked significant differences in the serum levels of MMP-2 between patients with different levels of kidney function and healthy controls. On the other hand, serum PAPP-A levels are increased from CKD 4, whereas in CKD 1-3 they are not different. Second, and more importantly, serum MMP-2 and PAPP-A levels are the independent correlates of proteinuria in CKD patients. Third, MMP-2 and PAPP-A are interrelated and correlate negatively with albumin, MMP-2 is also related to α -2-macroglobulin, a MMP inhibitor. These observations suggest that MMP-2 and PAPP-A are associated with proteinuria, indicating a contribution of these proteases to renal and vascular damage in patients with CKD.

Although, MMP-2 and PAPP-A correlated with estimated GFR, MMP-2 levels were not different between patients with different levels of renal function in this study. PAPP-A values were increased in late stages of CKD only. Indeed, a number of studies evaluated MMPs in patients with CKD [167, 168]. Progression of CKD was shown to be loosely related with the increase in MMP-2 serum levels in patients with CKD and patients on dialysis [152, 167, 311, 312]. On the other hand, other authors report no difference in the serum MMP-2 levels in relation to the level of renal function [172], or even depict decreased MMP-2 levels including dialysis patients [313]. Recently, it was indicated that serum levels of MMP-2 are one of the independent correlates of proteinuria and could be associated with intima media thickness and atherosclerotic plaque in patients with CKD. Moreover, increased values of MMP-2 and Fibroblast growth factor 23 in CKD were implied to accentuate higher risk of developing CV complications [314].

Increased PAPP-A levels are known to reflect changes in renal function [350] and could be a prognostic marker in dialysis patients [151, 152]. The association of PAPP-A and serum creatinine in our multivariate model supports this notion. Also, it was suggested that

PAPP-A may be produced by activated cells in atherosclerotic plaques and released to ECM [146].

We extend these findings by investigating CKD (1-5) patients of various nephropathies not yet undergoing dialysis for biochemical determinants of MMP-2 and PAPP-A serum levels.

The changes in proteases that occur in CKD patients may mediate both degradation of extracellular matrix components and cell proliferation and facilitate leukocyte function [161, 315]. There is still uncertainty as to whether abnormal regulation of proteases and their inhibitors represents a cause or simply an effect of the respective renal disease [316]. In nephropathies metalloproteinases appear to play a dual role as antifibrotic enzymes and as proinflammatory mediators, their exact biologic function may depend upon the level of MMP activity and the acuteness or the chronicity of the underlining renal disease [316].

Several factors were associated with MMP-2 and PAPP-A levels in our multivariate model; among them is proteinuria, supporting the concept that MMP-2 and PAPP-A are involved in proteinuria and suggesting that MMP-2 and PAPP-A levels could be markers of renal injury in patients with CKD. The novelty of our observation was the fact that serum levels of PAPP-A were associated with proteinuria in CKD patients. It is well known that proteinuria represents an independent risk factor for poor outcome in most types of glomerular disease and is related to the severity of tubulointerstitial injury [317]. The stimulation of tubular epithelial cells triggers a cascade of biological reactions that culminate in the transcriptional activation of genes for vasoactive and chemoattractant peptides [317, 318]. The increased release of such peptides may play a role in the accumulation of monocytes in renal interstitium and the stimulation of fibroblasts in the same area leading to interstitial inflammation, scarring and fibrosis [315, 319]. MMPs have been implicated in mesangioproliferative changes and tubulointerstitial damage, thus being involved in proteinuria [315, 320]. In addition, circulating MMP-2 has been shown to be correlated with proteinuria in kidney transplant recipients as well [321]. On the other hand, whether PAPP-A can degrade ECM remains unclear [146].

In this study, both serum MMP-2 and PAPP-A were negatively associated with albumin. Indeed, glomerular basal membrane is the site where albumin is lost into urine in CKD, it is also a site for MMP related damage and activation of inflammation and promotion of glomerular sclerosis, fibrosis, and hypertrophy in CKD. Podocytes are highly specialized

cells of glomeruli, which not only synthesize the components of GBM (collagen IV, fibronectin, laminin, etc) [322], but also produce the matrix degrading molecules such as MMP-2, MMP-9, etc [323]. Over-expression of MMP-2 and MMP-9 is related with progressive kidney damage. It was reported that albumin up-regulated the expression of MMP-2 and MMP-9 in podocytes at gene and protein levels in a time and dose dependent manner [323].

Another independent determinant of MMP-2 levels in this cohort of patients is α -2-macroglobulin. α -2-macroglobulin is a known MMP inhibitor [164, 324]. α -2-macroglobulin is one of the major plasma proteins in humans, and acts as a molecular trap for proteinase molecules. MMPs bound to α -2-Macroglobulin are unable to act on protein substrates. Trapped proteinase changes conformation of α -2-Macroglobulin and the changed conformation of the α -2-Macroglobulin and MMPs rapidly cleared from the circulation by the reticuloendothelial system. α -2-Macroglobulin is also an inflammatory, acute-phase protein. Hence, the relationship between MMP-2 activity and inflammation remains an important component of CKD that remains to be further studied.

Another interesting finding in this study is the interrelationship between MMP-2 and PAPP-A in CKD patients (1-5) not yet dialyzed. This association might represent a marker of an enhanced inflammatory state in asymptomatic CKD patients. MMPs are also potential indicators of arterial inflammation, and by degrading ECM, they contribute to the lipid rich, atherosclerotic plaque and finally to its rupture. PAPP-A was recently found to be abundantly expressed in both eroded and ruptured plaques, but in contrast, is only moderately expressed in stable plaques [146, 325]. These observations suggest that MMP-2 and PAPP-A might be causative risk factors linking renal and vascular damage in patients with CKD.

We observed a close association between declining haemoglobin and MMP-2. To the best of our knowledge, we are the first to describe this association. It is not clear how haemoglobin levels influence either the production or clearance of MMP 2. Haemoglobin is a major component of blood and a potent mediator both of oxidative stress and antioxidant function. Reduced tissue oxygenation associated with anaemia may elicit gelatinolytic activity of MMP-2. Certainly anaemia in CKD identifies patients at increased risk for progressive renal disease, hospitalization and premature death [326]. This association raises a possible role of declining haemoglobin in kidney injury partly through MMP-2 activation.

The present study used serum levels of MMP-2 and PAPP-A as surrogate markers to reflect changes in renal levels of these enzymes. However, there are several limitations to this approach that must be acknowledged. First, MMP activation occurs at different organs. Thus, serum levels do not necessarily reflect the net ECM proteolytic activity within the renal tissue. Data from previous clinical and experimental studies though suggest that differences in serum levels of MMP-2 and PAPP-A observed between reference controls and patients with CKD are likely to reflect differences at the renal level [167, 327]. Second, MMPs activities are regulated by tissue inhibitors of metalloproteinases (TIMPs) [328, 329], which have not been addressed in this study and may help elucidate the importance of our findings. Third, several therapies commonly prescribed for patients with CKD may influence MMPs function [330]. Also the relationship between serum levels of MMPs and plasma MMP activity was not assessed in this study since enzyme concentrations might change to compensate for irregularities in enzyme activity and vice versa.

In summary, the present study demonstrates that increased levels of MMP-2 are associated with PAPP-A, α -2-macroglobulin, proteinuria, lower haemoglobin, and lower albumin in CKD (1-5) patients of various nephropathies not yet undergoing dialysis. Similarly, the determinants of PAPP-A in CKD (1-5) patients are proteinuria, serum creatinine, and lower albumin. Both MMP-2 and PAPP-A are associated with proteinuria, a significant marker of renal damage and an independent risk marker for CVD as well. Additional studies are needed to determine whether an elevation in MMP-2 and PAPP-A are causes or consequences of renal and vascular damage in patients with CKD and if these MMPs are biomarkers for CVD in patients with CKD.

5.1.4 CHANGES IN SERUM LEVELS OF MMP-2, MMP-9 AND PAPP-A IN PATIENTS WITH VARIOUS NEPHROPATHIES

In the next study we focused to determine whether specific changes exist in the levels of MMP-2, MMP-9 and PAPP-A in patients with various nephropathies compared with those found in healthy subjects.

We indeed found that patients with various nephropathies have significant, marked differences in the serum levels of MMP-2, MMP-9 and PAPP-A compared with healthy subjects. Moreover, serum patterns of MMPs and PAPP-A considerably differed between

various histopathological types of glomerulonephritis and thus seems to be characteristic of each type of GN. Furthermore, with the exception of MMP-9, serum MMP-2 and PAPP-A concentrations inversely varied with the levels of renal function.

In IgAN patients, we observed decreased levels of MMP-2 contrasting with increased MMP-9 level as compared with healthy controls. Similarly, in IgAN patients studied by Akiyama et al. [163] serum MMP-2 levels were lower; MMP-9 were not evaluated in this study. Koide et al. [331] noted increased MMP-9 mRNA expression contrasting with low MMP-2 mRNA expression in circulating monocytes of IgAN patients. In contrast, Bauvois et al. [172] observed decreased levels of plasma MMP-9, whereas plasma MMP-2 levels as in our IgAN patients were lower as compared with healthy subjects. Urushihara et al. [171] reported enhanced MMP-9 expression in proliferative mesangial areas of glomeruli in kidney biopsy samples from IgAN patients. Interestingly, Danilewicz et al. [332] revealed significantly increased glomerular immunoexpression of MMP-2 but not MMP-9 in a Henoch-Schönlein nephritis groups as compared with idiopathic IgAN. PAPP-A levels in this study were comparable with those found in healthy controls. One possible reason for the difference in findings is that in IgAN, the expression levels of MMPs vary depending on the balance between attenuation of matrix accumulation and proliferation of mesangial cells via transient stimulation of the synthesis of MMP proteins. Thus, the markedly decreased MMP-2 serum levels and the increased MMP-9 concentrations as observed in our patients contribute to inter-individual differences in expression of MMPs in human renal disease in IgAN patients.

In MN patients, we observed an increase in serum MMP-9, whereas levels of serum MMP-2 and PAPP-A were not different in comparison with healthy control subjects. In contrast Akiyama et al. [163] Bauvois et al. [172] and Lods et al. [333] reported increased levels of MMP-2 contrasting with decreased levels of MMP-9. In contrast, Koide et al. [331] noted insignificant variation in MMP-2 and MMP-9 mRNA expression in peripheral blood monocytes of MN patients. In a model of membranous nephropathy, in murine Heymann nephritis, McMillan et al. [334] observed an increased expression of MMP-9 in cultured glomerular epithelial cells, which correlated with proteinuria, therefore suggesting a role of MMP-9 in the breakdown of the glomerular basement membrane. Though previous studies [163, 172, 333] reported increased MMP-2 and decreased MMP-9 level, the finding of increased MMP-9 serum concentrations in human MN nephritis is a novel finding, implicating that MMP-9 may play a role in glomerular disease in membranous nephropathy.

In our MCNS/FSGS nephrosis group, the serum MMP-2 and PAPP-A levels were unchanged, and there was a trend of higher serum MMP-9 concentrations as compared with controls. In contrast, Bauvois et al. [172] and Lods et al. [333] reported reduced serum MMP-9 levels accompanied by increased [333] or unchanged [172] MMP-2 levels. In experimental FSGS it was suggested that the enhanced cross-linking of extracellular matrix by tissue transglutaminase and decreased degradation due to the reduced active MMP-9 expression may be at least partially responsible for the deposition of fibronectin within injured glomeruli [335]. Thus in view of these contradictory findings it is difficult to conclude specific patterns of circulating MMPs in MCGN/FSGS group. Our data, though, support the notion that also in MCGN/FSGS group the specific changes in serum levels of MMPs and PAPP-A are distinct from those found in other patients with chronic nephropathy in this study.

In LN patients, we observed decreased levels of serum MMP-2, MMP-9 and PAPP-A levels as compared with healthy controls. Similarly, Robak et al. [336] observed lower serum levels of MMP-9 in patients with systemic lupus erythematosus (SLE) than in healthy controls. In contrast Akiyama et al. [163] found the elevation of serum MMP-9 levels and the unchanged MMP-2 levels in patients with SLE. Faber-Elman et al. [337] also observed the elevated activity of serum MMP-9 in patients with SLE. Makowski et al. [338] found that concentrations of neutrophil MMP-9 were inversely related with anti-dsDNA antibodies, a diagnostic marker of SLE. Recently Jiang et al. [339] revealed enhanced expression in MMP-9 and MMP-2 levels and their association with TIMPs in LN patients, when compared with healthy controls and patients without LN.

PAPP-A as a marker of complex coronary lesions investigated by Cosin-Sales et al. [340] in patients with atherosclerotic endothelial dysfunction as an independent predictor of the number of complex atherosclerotic carotid lesions. These findings support the notion that levels of circulating MMPs fluctuate in SLE, and raised levels of MMPs probably reflect an increased inflammatory process, whereas lower concentrations of MMP-2, MMP-9 and PAPP-A can result from the accumulation of MMPs in inflamed blood vessels and tissues.

In AAV patients, the levels of serum MMP-2, MMP-9 and PAPP-A were comparable with those found in healthy control subjects. There was a trend of higher serum levels of PAPP-A in AAV patients. Leeuw et al. [341] observed the increased carotid intima-thickness accompanied by the raised levels of hsCRP, MMP-3 and MMP-9 and TIMP in patients with Wegener granulomatosis, suggesting that enhanced inflammation and excessive vascular

remodelling are contributing factors in the development of accelerated atherosclerosis in Wegener granulomatosis. Bjerkeli et al. [342] noted that those patients with active disease had a selective up regulation of MMP-2 and MMP-8 compared with healthy controls, and a down regulation of TIMP-1 and TIMP-3 compared with other patients with Wegener granulomatosis. The reason of insignificant changes of MMP-s and PAPP-A in this study may reflect the use of immunosuppressive drugs in the developing remission patient group. Nevertheless, these findings suggest that disturbed MMPs and PAPP-A activity may have a role in the pathogenesis of AAV.

In the present study, an inverse correlation between both serum levels of MMP-2 and serum concentrations of PAPP-A, on one hand, and the degree of renal dysfunction as evaluated by eGFR, on the other, was found in the whole GN cohort. There was no correlation between serum MMP-9 and eGFR. These data are partially in line with findings by Chang et al. [161], but are in contrast to the study by Bauvois et al. [172] where no correlation to plasma aMMP-2 and MMP-9 with degree eGFR was found. In addition, serum PAPP-A was loosely correlated with eGFR in all GN groups, and these findings are in line with those of Peiskerová et al. [314], who observed an elevation of serum PAPP-A levels in late stages of chronic kidney disease. Such discrepancies may result from the methodology and in the different profiles between the groups examined.

In conclusion, our data confirm that serum levels of MMP-2, MMP-9, and PAPP-A are markedly altered in patients with various nephropathies as compared with healthy subjects. Moreover, the patterns of MMP-2, MMP-9, and PAPP-A concentrations significantly differed between various histopathological types of nephropathies, reflecting the involvement of different mechanisms in regulation of glomerular and tubulinterstitial fibrosis. Decreased barrier function of peritubular capillaries and endothelial dysfunction following renal injury in various nephropathies suggest that MMPs and PAPP-A leak into vascular system, which may account for the presence of MMPs and PAPP-A in human serum. Not only are the tissue levels of MMPs and PAPP-A changed in patients with various nephropathies, but also serum levels of MMP-2, MMP-9 and PAPP-A are altered, suggesting that circulating MMPs and PAPP-A levels may provide a biologically relevant marker of connective tissue metabolism in patients with various nephropathies. In addition significant relationships between serum MMP-2 and PAPP-A and the levels of eGFR were found, implying that these biomarkers are cleared by the kidney. However, the determination of these putative mechanisms would require further careful examination. Thus, further studies that

assess the exact role of MMPs and PAPP-A in nephropathies are needed, not only to understand the pathogenic mechanism of various nephropathies, but also to improve current therapeutic strategies.

5.2 EVALUATION OF NOVEL BIOMARKERS (PLGF, PAPP-A, sRAGE, S100A12 (EN-RAGE), AND HMGB-1 IN PATIENTS WITH ACUTE KIDNEY INJURY

This is the first study where we demonstrate the circulating levels of PLGF, PAPP-A, sRAGE, EN-RAGE and HMGB-1 levels in patients with AKI requiring RRT. Significantly higher levels of PAPP-A, EN-RAGE and HMGB-1, but not increased levels of sRAGE and PIGF were observed in the serum of patients with AKI as compared with controls. Further, this study demonstrates significant independent associations of PAPP-A with markers of nutrition, and the associations of PIGF, EN-RAGE, HMGB-1 with inflammatory parameters in these patients for the first time.

Although PIGF levels in AKI patients were not elevated, PIGF was significantly correlated with inflammatory markers CRP and fibrinogen and inversely with a negative inflammatory marker prealbumin. However, only CRP was positively associated with PIGF levels by multivariate analysis. CRP is a short pentraxin and an established biomarker of inflammation in kidney disease [247]. A recent study has suggested that the level of the ratio of CRP to prealbumin was associated with mortality of AKI patients [343]. Moreover, lower serum prealbumin levels were strongly associated with a higher risk of death independent of AKI severity [344]. On the other hand, serum fibrinogen is independently predictive of cardiovascular and all-cause mortality in end-stage kidney disease [345] and in patients with CKD [346]. In AKI serum fibrinogen levels were comparable with those found in healthy controls [347]. It is thus conceivable that PIGF is released from endothelial cells, among others, in response to inflammation in AKI.

PAPP-A levels were increased in AKI patients in comparison with healthy controls, but were comparable to those found in CKD 5 and HD patients. In line with previous report, PAPP-A is elevated in HD patients [348] and is a prognostic marker in dialysis patients [152]. The PAPP-A levels were also significantly decreased in dialysis patients after successful kidney transplantation, but remained higher than in control group [349]. The mechanisms of

PAPP-A increase most probably include the increased synthesis, but also the decreased clearance of PAPP-A in patients with decreased renal function, including the patients with AKI. In this study, PAPP-A levels were independently associated with markers of nutrition: transferrin and negatively with albumin and prealbumin. These results permit the conclusion that PAPP-A levels are elevated in patients with AKI and related to markers of nutrition, but are not related to inflammatory markers, as in HD patients in this and previous studies [311].

We provide here evidence that sRAGE levels are increased but not significantly in the setting of AKI. An explanation for the comparable sRAGE levels in AKI might be an enhanced consumption of this molecule. sRAGE acts as an anti-inflammatory “decoy” by binding and preventing their interaction with cell surface RAGE, suppresses the RAGE mediated inflammatory response [180]. The ligands EN-RAGE and HMGB-1 binding to sRAGE might influence the levels of sRAGE and increase the propensity towards inflammation. RAGE ligands therefore have better binding across to cell membrane receptor, the binding of which activates the inflammatory pathways. Interestingly, in a recent study in septic AKI patients sRAGE levels were elevated [350]. In CKD and HD patients serum sRAGE levels were also increased in this and the previous study and was inversely related to inflammation [293]. The correlation revealed in our AKI patients between serum sRAGE levels and declining haemoglobin suggest that reduced tissue oxygenation associated with anaemia may contribute to the formation of AGEs and activation of RAGE with possible toxic effect of them on hematopoiesis, while sRAGE might inhibit their pathological effect. We cannot also exclude the effect of amelioration of endothelial and inflammatory injuries on the serum sRAGE activity in AKI. sRAGE levels in AKI, similarly as in CKD and HD, could be an indicator of enhanced RAGE expression as counter-regulatory system against endothelial damage i.e. inflammation and oxidative stress. Given the importance of anaemia in decreased renal function, the association between sRAGE and anaemia in AKI patients deserves further studies.

In the present study, EN-RAGE levels were significantly increased in AKI patients, but not in CKD5 and HD patients. These results are in line with our previous study where the serum concentrations of CKD patients and HD were not elevated in comparison with healthy controls [351]. Similarly as in CKD, HD and peritoneal dialysis patients [351, 352], also in AKI patients a relation of serum EN-RAGE levels to markers of inflammation was found. Specifically, EN-RAGE concentrations were independently associated with orosomucoid and ferritin.

Plasma EN-RAGE triggers the RAGE pathway as proinflammatory ligand activating key inflammatory signals such as NF- κ B and MAP kinase and stimulates cell adhesion molecules. Circulating EN-RAGE is associated with CVD events and CVD-related mortality in HD patients, which partly explained by its link to inflammation [201], and is related to mortality of HD patients due to infection [353]. Orosomucoid, being an acute phase protein, contributes to immune response in inflammatory states modulating chemotaxis of neutrophils, superoxide generation and aggregation [309]. On the other hand, a recent study in a murine model of acute renal failure has shown that orosomucoid partially restored activity of clotting and complement systems in acute renal failure [354]. This effect may be due to accumulation of orosomucoid in renal tissue and its protective action in situ. Taken together, higher serum EN-RAGE levels and relation to inflammatory markers in this study may be associated with amplified inflammatory response and vascular damage in AKI patients.

In the present study all AKI patients in our study had elevated circulating HMGB-1 levels as compared with controls. We could also show that HMGB-1 levels were independently associated with leukocyte count and negatively with proteinuria in AKI setting. Although, we could not exclude patients with high CRP levels in AKI patients, in multivariate analysis no relationship to CRP levels were found. HMGB-1 is one of the high-affinity ligands for RAGE/sRAGE, a potent cytokine playing an important role in the pathogenesis of inflammation. Previous studies have shown that HMGB-1 differs from early innate proinflammatory cytokines, such as TNF and IL-1, in endotoxaemia and sepsis models [207, 208]. HMGB-1 release occurs in response to a number of alarm signals including endotoxin, interferons, TNFs and largely is a consequence of NF- κ B activation and HMGB-1 acetylation at its nuclear localization site [203, 355]. This induces vesicular sequestration and leads to extracellular HMGB-1 release [210, 356]. In addition, passive diffusion from necrotic cells might occur [208, 210]. Another interesting finding is the negative association of HMGB-1 and proteinuria in AKI setting, supporting the concept that HMGB-1 could be a marker of renal injury in patients with AKI. Whether high HMGB-1 levels in AKI are the consequences of the disease or a potential contributing factor to the disease needs to be elucidated.

The most frequent cause of AKI in the Intensive Care Units is sepsis [357]. Endothelial activation defined as upregulation of adhesion molecules by proinflammatory cytokines, may be central to the development of sepsis induced AKI. In this study the CKD and HD patients with overt inflammation were excluded. We endeavored to include a comparative cohort of AKI patients specifically without sepsis. Although, we have not

included the patients with sepsis in this study, the association of studied biomarkers with inflammatory markers support the notion that also in sepsis induced AKI the levels of studied biomarkers might be changed. Indeed, pretransplant inflammation including the elevation of PAPP-A in transplant recipients might play an important role in the pathogenesis of ischemic AKI and could be a risk factor for the development of delayed graft function [358]. Serum PAPP-A levels frequently increases in patients with severe sepsis and appears to be associated with sepsis related myocardial dysfunction [359]. PlGF levels are elevated in preclinical models of sepsis [360]. PlGF protects liver endothelial cells against septic injury, explaining why sepsis morbidity is increased following genetic or pharmacological PlGF blockade [287, 360]. sRAGE levels were elevated during acute lung injury, regardless of the presence or absence of severe sepsis [361]. Also in another study in septic patients an elevation of sRAGE levels were shown [362]. Non-survivors had higher plasma sRAGE concentrations than survivors. In addition, recently also in septic AKI patients sRAGE levels were elevated [350]. In contrast, in a recent study the sRAGE levels were not changed in severe sepsis, while the EN-RAGE concentrations were significantly increased in patients with severe sepsis stratified to the three most common infectious sources (lungs, abdomen, and urinary tract) [363]. In addition, HMGB-1 has been identified as late cytokine mediator of endotoxaemia and sepsis [356, 364, 365]. HMGB-1 was persistently elevated in patients with severe sepsis and severe shock [366]. Taken together, PlGF, PAPP-A, sRAGE, EN-RAGE and HMGB-1 might play a role also in sepsis induced AKI. Further studies are warranted to test the clinical utility of these biomarkers in managing patients with sepsis and AKI and to better understand their relationship with kidney morphology during acute kidney injury.

There are several limitations in this study, including small sample size of adult patients with severe AKI (RIFLE category failure). Nevertheless, this is the first study to report an association of studied biomarkers and relevant parameters in AKI patients. Second, the studied population was composed by heterogeneous AKI patients treated at single centre of faculty hospital. Third, we did not compare studied biomarkers with established one such as neutrophil gelatinase associated lipocalin. Finally, we did not perform a kinetic study on novel biomarkers including more frequent sampling.

The study presented here provides first insight into levels of circulating PlGF, PAPP-A, sRAGE, EN-RAGE and HMGB-1 in patients with AKI. The PAPP-A, EN-RAGE and HMGB-1 levels are significantly elevated, but sRAGE and PlGF levels are not increased in AKI patients. Whereas PlGF, EN-RAGE, and HMGB-1 levels are significantly related to

inflammatory markers, PAPP-A levels are associated with markers of nutrition in AKI setting. Larger, prospective clinical studies are needed to confirm the results of our single centre study.

6 CONCLUSION

The aim of the thesis was to study novel promising biomarkers of kidney function, the underlying biochemical and pathophysiological processes, chronic inflammation and/or cardiovascular risk – placental growth factor (PIGF), pregnancy associated plasma protein A (PAPP-A), matrix metalloproteinase 2 (MMP-2), matrix metalloproteinase 9 (MMP-9), soluble receptor for advanced glycation end products, calcium binding protein S100A12 or extracellular newly identified RAGE binding protein (EN-RAGE), and high mobility group box protein-1 (HMGB-1) in patients with renal diseases including CKD, HD and AKI patients. Moreover, the study aimed to testify the hypothesis that these biomarkers are related to inflammatory and nutritional parameters, atherosclerosis, and cardiovascular disease.

We have observed that PIGF, an endogenous proatherogenic cytokine, is elevated in patients with decreased renal function. PIGF is present in the urine, and its serum and urine levels are interrelated. It is higher in CKD patients with cardiovascular disease.

We have shown that S100A12 (EN-RAGE), a sensitive and specific marker of localized inflammatory process, is not elevated in patients with decreased renal function at stable clinical status without signs of overt inflammation. Even in these basal conditions, it is significantly related to inflammatory markers. In addition, this study also shows that S100A12 is present in the urine, and urine levels are higher in comparison with those in serum and correlate with renal function.

We have demonstrated that increased levels of MMP-2 are associated with PAPP-A, α -2-Macroglobulin, proteinuria, lower haemoglobin and lower albumin in CKD (1-5) patients of various nephropathies not yet undergoing dialysis. Similarly, the determinants of PAPP-A in CKD (1-5) patients are proteinuria, serum creatinine, and lower albumin. Both MMP-2 and PAPP-A are associated with proteinuria, a significant marker of renal damage and an independent risk marker for CVD as well.

We have provided the first insight into levels of circulating PIGF, PAPP-A, sRAGE, EN-RAGE and HMGB-1 in patients with AKI. The PAPP-A, EN-RAGE and HMGB-1 levels are significantly elevated, but sRAGE and PIGF levels are not increased in AKI patients. Whereas PIGF, EN-RAGE, and HMGB-1 levels are significantly related to inflammatory markers, PAPP-A levels are associated with markers of nutrition in AKI setting.

This thesis demonstrated potential clinical use of several candidate biomarkers for risk stratification in patients presenting with CKD, AKI, ESRD treated by HD and for improved understanding of the biochemistry and pathophysiology of patients with reduced renal function. Concerns that have been addressed for biomarkers reflecting pro-inflammatory, anti-inflammatory, metabolic, nutritional and proatherogenic factors will need to be validated in future studies.

7 REFERENCES

1. Glasscock RJ, Winearls C: An epidemic of chronic kidney disease: fact or fiction? *Nephrol Dial Transplant* 2008, 23(4):1117-1121.
2. Liaño F, Pascual J: Epidemiology of acute renal failure: a prospective, multicenter, community-based study. Madrid Acute Renal Failure Study Group. *Kidney Int* 1996, 50(3):811-818.
3. Sulková S: [Epidemiology of functional disorders of the kidneys]. *Vnitr Lek* 2003, 49(5):358-361.
4. Schiffrin EL, Lipman ML, Mann JF: Chronic kidney disease: effects on the cardiovascular system. *Circulation* 2007, 116(1):85-97.
5. Biological markers in environmental health research. Committee on Biological Markers of the National Research Council. *Environ Health Perspect* 1987, 74:3-9.
6. Kidney Disease: Improving Global Outcomes (KDIGO) CKD Work Group. KDIGO 2012 Clinical Practice Guideline for the Evaluation and Management of Chronic Kidney Disease. In., vol. Suppl. 2013; 1-150.: *Kidney Int*; 2013: 1-150.
7. Foundation NK: K/DOQI clinical practice guidelines for chronic kidney disease: evaluation, classification, and stratification. *Am J Kidney Dis* 2002, 39(2 Suppl 1):S1-266.
8. Stevens PE, Levin A, Members* KDIGO CKD WG: Evaluation and management of chronic kidney disease: synopsis of the kidney disease: improving global outcomes 2012 clinical practice guideline. *Ann Intern Med* 2013, 158(11):825-830.
9. Garrido AM, Griendling KK: NADPH oxidases and angiotensin II receptor signaling. *Mol Cell Endocrinol* 2009, 302(2):148-158.
10. Farmer DG, Kennedy S: RAGE, vascular tone and vascular disease. *Pharmacol Ther* 2009, 124(2):185-194.
11. Gu JW, Tian N, Shparago M, Tan W, Bailey AP, Manning RD: Renal NF-kappaB activation and TNF-alpha upregulation correlate with salt-sensitive hypertension in Dahl salt-sensitive rats. *Am J Physiol Regul Integr Comp Physiol* 2006, 291(6):R1817-1824.
12. Lehoux S, Castier Y, Tedgui A: Molecular mechanisms of the vascular responses to haemodynamic forces. *J Intern Med* 2006, 259(4):381-392.
13. Marrero MB, Fulton D, Stepp D, Stern DM: Angiotensin II-induced signaling pathways in diabetes. *Curr Diabetes Rev* 2005, 1(2):197-202.
14. Park HS, Jung HY, Park EY, Kim J, Lee WJ, Bae YS: Cutting edge: direct interaction of TLR4 with NAD(P)H oxidase 4 isozyme is essential for lipopolysaccharide-induced production of reactive oxygen species and activation of NF-kappa B. *J Immunol* 2004, 173(6):3589-3593.
15. Pueyo ME, Gonzalez W, Nicoletti A, Savoie F, Arnal JF, Michel JB: Angiotensin II stimulates endothelial vascular cell adhesion molecule-1 via nuclear factor-kappaB activation induced by intracellular oxidative stress. *Arterioscler Thromb Vasc Biol* 2000, 20(3):645-651.
16. Tian N, Moore RS, Braddy S, Rose RA, Gu JW, Hughson MD, Manning RD: Interactions between oxidative stress and inflammation in salt-sensitive hypertension. *Am J Physiol Heart Circ Physiol* 2007, 293(6):H3388-3395.
17. Zoccali C: Endothelial dysfunction and the kidney: emerging risk factors for renal insufficiency and cardiovascular outcomes in essential hypertension. *J Am Soc Nephrol* 2006, 17(4 Suppl 2):S61-63.

18. Hartge MM, Unger T, Kintscher U: The endothelium and vascular inflammation in diabetes. *Diab Vasc Dis Res* 2007, 4(2):84-88.
19. Ochodnický P, Henning RH, van Dokkum RP, de Zeeuw D: Microalbuminuria and endothelial dysfunction: emerging targets for primary prevention of end-organ damage. *J Cardiovasc Pharmacol* 2006, 47 Suppl 2:S151-162; discussion S172-156.
20. Ronco C, Chionh CY, Haapio M, Anavekar NS, House A, Bellomo R: The cardiorenal syndrome. *Blood Purif* 2009, 27(1):114-126.
21. Ronco C, Haapio M, House AA, Anavekar N, Bellomo R: Cardiorenal syndrome. *J Am Coll Cardiol* 2008, 52(19):1527-1539.
22. Ronco C, House AA, Haapio M: Cardiorenal syndrome: refining the definition of a complex symbiosis gone wrong. *Intensive Care Med* 2008, 34(5):957-962.
23. Ronco C, House AA, Haapio M: Cardiorenal and renocardiac syndromes: the need for a comprehensive classification and consensus. *Nat Clin Pract Nephrol* 2008, 4(6):310-311.
24. Chade AR, Lerman A, Lerman LO: Kidney in early atherosclerosis. *Hypertension* 2005, 45(6):1042-1049.
25. Methe H, Weis M: Atherogenesis and inflammation--was Virchow right? *Nephrol Dial Transplant* 2007, 22(7):1823-1827.
26. Merino A, Nogueras S, Buendía P, Ojeda R, Carracedo J, Ramirez-Chamond R, Martin-Malo A, Aljama P: Microinflammation and endothelial damage in haemodialysis. *Contrib Nephrol* 2008, 161:83-88.
27. Stenvinkel P: Endothelial dysfunction and inflammation-is there a link? *Nephrol Dial Transplant* 2001, 16(10):1968-1971.
28. Davignon J, Ganz P: Role of endothelial dysfunction in atherosclerosis. *Circulation* 2004, 109(23 Suppl 1):III27-32.
29. Morena M, Delbosc S, Dupuy AM, Canaud B, Cristol JP: Overproduction of reactive oxygen species in end-stage renal disease patients: a potential component of haemodialysis-associated inflammation. *Hemodial Int* 2005, 9(1):37-46.
30. Annuk M, Zilmer M, Lind L, Linde T, Fellström B: Oxidative stress and endothelial function in chronic renal failure. *J Am Soc Nephrol* 2001, 12(12):2747-2752.
31. Himmelfarb J, Stenvinkel P, Ikizler TA, Hakim RM: The elephant in uremia: oxidant stress as a unifying concept of cardiovascular disease in uremia. *Kidney Int* 2002, 62(5):1524-1538.
32. Zhang DX, Gutterman DD: Mitochondrial reactive oxygen species-mediated signaling in endothelial cells. *Am J Physiol Heart Circ Physiol* 2007, 292(5):H2023-2031.
33. Sydow K, Münzel T: ADMA and oxidative stress. *Atheroscler Suppl* 2003, 4(4):41-51.
34. Nanayakkara PW, Teerlink T, Stehouwer CD, Allajar D, Spijkerman A, Schalkwijk C, ter Wee PM, van Guldener C: Plasma asymmetric dimethylarginine (ADMA) concentration is independently associated with carotid intima-media thickness and plasma soluble vascular cell adhesion molecule-1 (sVCAM-1) concentration in patients with mild-to-moderate renal failure. *Kidney Int* 2005, 68(5):2230-2236.
35. Stenvinkel P, Lindholm B, Heimbürger M, Heimbürger O: Elevated serum levels of soluble adhesion molecules predict death in pre-dialysis patients: association with malnutrition, inflammation, and cardiovascular disease. *Nephrol Dial Transplant* 2000, 15(10):1624-1630.
36. Bonomini M, Reale M, Santarelli P, Stuard S, Settefrati N, Albertazzi A: Serum levels of soluble adhesion molecules in chronic renal failure and dialysis patients. *Nephron* 1998, 79(4):399-407.

37. Hornig C, Barleon B, Ahmad S, Vuorela P, Ahmed A, Weich HA: Release and complex formation of soluble VEGFR-1 from endothelial cells and biological fluids. *Lab Invest* 2000, 80(4):443-454.
38. Malyszko J: Mechanism of endothelial dysfunction in chronic kidney disease. *Clin Chim Acta* 2010, 411(19-20):1412-1420.
39. Barton GM: A calculated response: control of inflammation by the innate immune system. *J Clin Invest* 2008, 118(2):413-420.
40. Ramirez R, Carracedo J, Berdud I, Carretero D, Merino A, Rodríguez M, Tetta C, Martín-Malo A, Aljama P: Microinflammation in haemodialysis is related to a preactivated subset of monocytes. *Hemodial Int* 2006, 10 Suppl 1:S24-27.
41. Yilmaz MI, Sonmez A, Saglam M, Yaman H, Cayci T, Kilic S, Eyileten T, Caglar K, Oguz Y, Vural A *et al*: Reduced proteinuria using ramipril in diabetic CKD stage 1 decreases circulating cell death receptor activators concurrently with ADMA. A novel pathophysiological pathway? *Nephrol Dial Transplant* 2010, 25(10):3250-3256.
42. Rodríguez-Puyol M, Griera-Merino M, Pérez-Rivero G, Díez-Marqués ML, Ruiz-Torres MP, Rodríguez-Puyol D: Angiotensin II induces a rapid and transient increase of reactive oxygen species. *Antioxid Redox Signal* 2002, 4(6):869-875.
43. Ron D, Oren I, Aviram M, Better OS, Brook JG: Accumulation of lipoprotein remnants in patients with chronic renal failure. *Atherosclerosis* 1983, 46(1):67-75.
44. Nestel PJ, Fidge NH, Tan MH: Increased lipoprotein-remnant formation in chronic renal failure. *N Engl J Med* 1982, 307(6):329-333.
45. Grützmacher P, März W, Peschke B, Gross W, Schoeppe W: Lipoproteins and apolipoproteins during the progression of chronic renal disease. *Nephron* 1988, 50(2):103-111.
46. Fuh MM, Lee CM, Jeng CY, Shen DC, Shieh SM, Reaven GM, Chen YD: Effect of chronic renal failure on high-density lipoprotein kinetics. *Kidney Int* 1990, 37(5):1295-1300.
47. Dounousi E, Papavasiliou E, Makedou A, Ioannou K, Katopodis KP, Tselepis A, Siamopoulos KC, Tsakiris D: Oxidative stress is progressively enhanced with advancing stages of CKD. *Am J Kidney Dis* 2006, 48(5):752-760.
48. Karamouzis I, Sarafidis PA, Karamouzis M, Iliadis S, Haidich AB, Sioulis A, Triantos A, Vavatsi-Christaki N, Grekas DM: Increase in oxidative stress but not in antioxidant capacity with advancing stages of chronic kidney disease. *Am J Nephrol* 2008, 28(3):397-404.
49. Chen F, Castranova V, Shi X: New insights into the role of nuclear factor-kappaB in cell growth regulation. *Am J Pathol* 2001, 159(2):387-397.
50. Hayden MS, Ghosh S: Shared principles in NF-kappaB signaling. *Cell* 2008, 132(3):344-362.
51. Rangan G, Wang Y, Harris D: NF-kappaB signalling in chronic kidney disease. *Front Biosci* 2009, 14:3496-3522.
52. Morigi M, Macconi D, Zoja C, Donadelli R, Buelli S, Zanchi C, Ghilardi M, Remuzzi G: Protein overload-induced NF-kappaB activation in proximal tubular cells requires H(2)O(2) through a PKC-dependent pathway. *J Am Soc Nephrol* 2002, 13(5):1179-1189.
53. Zoja C, Donadelli R, Colleoni S, Figliuzzi M, Bonazzola S, Morigi M, Remuzzi G: Protein overload stimulates RANTES production by proximal tubular cells depending on NF-kappa B activation. *Kidney Int* 1998, 53(6):1608-1615.
54. Birn H, Christensen EI: Renal albumin absorption in physiology and pathology. *Kidney Int* 2006, 69(3):440-449.

55. Mezzano SA, Barria M, Droguett MA, Burgos ME, Ardiles LG, Flores C, Egido J: Tubular NF-kappaB and AP-1 activation in human proteinuric renal disease. *Kidney Int* 2001, 60(4):1366-1377.
56. Benigni A, Remuzzi G: How renal cytokines and growth factors contribute to renal disease progression. *Am J Kidney Dis* 2001, 37(1 Suppl 2):S21-24.
57. Biswal S, Thimmulappa RK, Harvey CJ: Experimental therapeutics of Nrf2 as a target for prevention of bacterial exacerbations in COPD. *Proc Am Thorac Soc* 2012, 9(2):47-51.
58. Dworski R, Han W, Blackwell TS, Hoskins A, Freeman ML: Vitamin E prevents NRF2 suppression by allergens in asthmatic alveolar macrophages in vivo. *Free Radic Biol Med* 2011, 51(2):516-521.
59. Rieber N, Hector A, Kuijpers T, Roos D, Hartl D: Current concepts of hyperinflammation in chronic granulomatous disease. *Clin Dev Immunol* 2012, 2012:252460.
60. Kim HJ, Vaziri ND: Contribution of impaired Nrf2-Keap1 pathway to oxidative stress and inflammation in chronic renal failure. *Am J Physiol Renal Physiol* 2010, 298(3):F662-671.
61. Kim J, Cha YN, Surh YJ: A protective role of nuclear factor-erythroid 2-related factor-2 (Nrf2) in inflammatory disorders. *Mutat Res* 2010, 690(1-2):12-23.
62. Kim HJ, Sato T, Rodríguez-Iturbe B, Vaziri ND: Role of intrarenal angiotensin system activation, oxidative stress, inflammation, and impaired nuclear factor-erythroid-2-related factor 2 activity in the progression of focal glomerulosclerosis. *J Pharmacol Exp Ther* 2011, 337(3):583-590.
63. Goodman WG, London G, Amann K, Block GA, Giachelli C, Hruska KA, Ketteler M, Levin A, Massy Z, McCarron DA *et al*: Vascular calcification in chronic kidney disease. *Am J Kidney Dis* 2004, 43(3):572-579.
64. Shroff RC, Shah V, Hiorns MP, Schoppet M, Hofbauer LC, Hawa G, Schurgers LJ, Singhal A, Merryweather I, Brogan P *et al*: The circulating calcification inhibitors, fetuin-A and osteoprotegerin, but not matrix Gla protein, are associated with vascular stiffness and calcification in children on dialysis. *Nephrol Dial Transplant* 2008, 23(10):3263-3271.
65. Moe SM, Chen NX: Pathophysiology of vascular calcification in chronic kidney disease. *Circ Res* 2004, 95(6):560-567.
66. Temmar M, Liabeuf S, Renard C, Czernichow S, Esper NE, Shahapuni I, Presne C, Makdassi R, Andrejak M, Tribouilloy C *et al*: Pulse wave velocity and vascular calcification at different stages of chronic kidney disease. *J Hypertens* 2010, 28(1):163-169.
67. Block GA, Raggi P, Bellasi A, Kooienga L, Spiegel DM: Mortality effect of coronary calcification and phosphate binder choice in incident haemodialysis patients. *Kidney Int* 2007, 71(5):438-441.
68. Brewer LC, Michos ED, Reis JP: Vitamin D in atherosclerosis, vascular disease, and endothelial function. *Curr Drug Targets* 2011, 12(1):54-60.
69. Cozzolino M, Ketteler M, Zehnder D: The vitamin D system: a crosstalk between the heart and kidney. *Eur J Heart Fail* 2010, 12(10):1031-1041.
70. Judd SE, Tangpricha V: Vitamin D deficiency and risk for cardiovascular disease. *Am J Med Sci* 2009, 338(1):40-44.
71. Husain K, Suarez E, Isidro A, Ferder L: Effects of paricalcitol and enalapril on atherosclerotic injury in mouse aortas. *Am J Nephrol* 2010, 32(4):296-304.

72. Mizobuchi M, Finch JL, Martin DR, Slatopolsky E: Differential effects of vitamin D receptor activators on vascular calcification in uremic rats. *Kidney Int* 2007, 72(6):709-715.
73. Andress DL: Vitamin D in chronic kidney disease: a systemic role for selective vitamin D receptor activation. *Kidney Int* 2006, 69(1):33-43.
74. HW S: The kidney: structure and function in health and disease. In., vol. 764: New York: Oxford University Press; 1951.
75. Bellomo R, Ronco C, Kellum JA, Mehta RL, Palevsky P, workgroup ADQI: Acute renal failure - definition, outcome measures, animal models, fluid therapy and information technology needs: the Second International Consensus Conference of the Acute Dialysis Quality Initiative (ADQI) Group. *Crit Care* 2004, 8(4):R204-212.
76. Ronco C, Kellum JA, Mehta R: Acute dialysis quality initiative (ADQI). *Nephrol Dial Transplant* 2001, 16(8):1555-1558.
77. Levin A, Warnock DG, Mehta RL, Kellum JA, Shah SV, Molitoris BA, Ronco C, Group AKINW: Improving outcomes from acute kidney injury: report of an initiative. *Am J Kidney Dis* 2007, 50(1):1-4.
78. Mehta RL, Kellum JA, Shah SV, Molitoris BA, Ronco C, Warnock DG, Levin A, Network AKI: Acute Kidney Injury Network: report of an initiative to improve outcomes in acute kidney injury. *Crit Care* 2007, 11(2):R31.
79. Morgera S, Schneider M, Neumayer HH: Long-term outcomes after acute kidney injury. *Crit Care Med* 2008, 36(4 Suppl):S193-197.
80. Ishani A, Xue JL, Himmelfarb J, Eggers PW, Kimmel PL, Molitoris BA, Collins AJ: Acute kidney injury increases risk of ESRD among elderly. *J Am Soc Nephrol* 2009, 20(1):223-228.
81. Lo LJ, Go AS, Chertow GM, McCulloch CE, Fan D, Ordoñez JD, Hsu CY: Dialysis-requiring acute renal failure increases the risk of progressive chronic kidney disease. *Kidney Int* 2009, 76(8):893-899.
82. Hsu CY, Chertow GM, McCulloch CE, Fan D, Ordoñez JD, Go AS: Nonrecovery of kidney function and death after acute on chronic renal failure. *Clin J Am Soc Nephrol* 2009, 4(5):891-898.
83. <http://renalfellow.blogspot.cz/2008/08/aki-criteria.html>.
84. Molitoris BA: Transitioning to therapy in ischemic acute renal failure. *J Am Soc Nephrol* 2003, 14(1):265-267.
85. Legrand M, Mik EG, Johannes T, Payen D, Ince C: Renal hypoxia and dysoxia after reperfusion of the ischemic kidney. *Mol Med* 2008, 14(7-8):502-516.
86. Feldkamp T, Park JS, Pasupulati R, Amora D, Roeser NF, Venkatachalam MA, Weinberg JM: Regulation of the mitochondrial permeability transition in kidney proximal tubules and its alteration during hypoxia-reoxygenation. *Am J Physiol Renal Physiol* 2009, 297(6):F1632-1646.
87. Brooks C, Wei Q, Cho SG, Dong Z: Regulation of mitochondrial dynamics in acute kidney injury in cell culture and rodent models. *J Clin Invest* 2009, 119(5):1275-1285.
88. Basile DP, Friedrich JL, Spahic J, Knipe N, Mang H, Leonard EC, Changizi-Ashtiyani S, Bacallao RL, Molitoris BA, Sutton TA: Impaired endothelial proliferation and mesenchymal transition contribute to vascular rarefaction following acute kidney injury. *Am J Physiol Renal Physiol* 2011, 300(3):F721-733.
89. Goligorsky MS, Patschan D, Kuo MC: Weibel-Palade bodies--sentinels of acute stress. *Nat Rev Nephrol* 2009, 5(7):423-426.
90. Schrier RW, Wang W, Poole B, Mitra A: Acute renal failure: definitions, diagnosis, pathogenesis, and therapy. *J Clin Invest* 2004, 114(1):5-14.

91. Sutton TA, Fisher CJ, Molitoris BA: Microvascular endothelial injury and dysfunction during ischemic acute renal failure. *Kidney Int* 2002, 62(5):1539-1549.
92. Bonventre JV, Zuk A: Ischemic acute renal failure: an inflammatory disease? *Kidney Int* 2004, 66(2):480-485.
93. Jang HR, Rabb H: The innate immune response in ischemic acute kidney injury. *Clin Immunol* 2009, 130(1):41-50.
94. Kinsey GR, Li L, Okusa MD: Inflammation in acute kidney injury. *Nephron Exp Nephrol* 2008, 109(4):e102-107.
95. Chen J, John R, Richardson JA, Shelton JM, Zhou XJ, Wang Y, Wu QQ, Hartono JR, Winterberg PD, Lu CY: Toll-like receptor 4 regulates early endothelial activation during ischemic acute kidney injury. *Kidney Int* 2011, 79(3):288-299.
96. Wu H, Ma J, Wang P, Corpuz TM, Panchapakesan U, Wyburn KR, Chadban SJ: HMGB-1 contributes to kidney ischemia reperfusion injury. *J Am Soc Nephrol* 2010, 21(11):1878-1890.
97. Nath KA, Norby SM: Reactive oxygen species and acute renal failure. *Am J Med* 2000, 109(8):665-678.
98. Hillege HL, Nitsch D, Pfeffer MA, Swedberg K, McMurray JJ, Yusuf S, Granger CB, Michelson EL, Ostergren J, Cornel JH *et al*: Renal function as a predictor of outcome in a broad spectrum of patients with heart failure. *Circulation* 2006, 113(5):671-678.
99. Smith GL, Lichtman JH, Bracken MB, Shlipak MG, Phillips CO, DiCapua P, Krumholz HM: Renal impairment and outcomes in heart failure: systematic review and meta-analysis. *J Am Coll Cardiol* 2006, 47(10):1987-1996.
100. Hawkins R: New biomarkers of acute kidney injury and the cardio-renal syndrome. *Korean J Lab Med* 2011, 31(2):72-80.
101. Li X, Eriksson U: Novel PDGF family members: PDGF-C and PDGF-D. *Cytokine Growth Factor Rev* 2003, 14(2):91-98.
102. Iyer S, Leonidas DD, Swaminathan GJ, Maglione D, Battisti M, Tucci M, Persico MG, Acharya KR: The crystal structure of human placenta growth factor-1 (PlGF-1), an angiogenic protein, at 2.0 Å resolution. *J Biol Chem* 2001, 276(15):12153-12161.
103. Gluzman-Poltorak Z, Cohen T, Herzog Y, Neufeld G: Neuropilin-2 is a receptor for the vascular endothelial growth factor (VEGF) forms VEGF-145 and VEGF-165 [corrected]. *J Biol Chem* 2000, 275(24):18040-18045.
104. Mamluk R, Gechtman Z, Kutcher ME, Gasiunas N, Gallagher J, Klagsbrun M: Neuropilin-1 binds vascular endothelial growth factor 165, placenta growth factor-2, and heparin via its b1b2 domain. *J Biol Chem* 2002, 277(27):24818-24825.
105. Park JE, Chen HH, Winer J, Houck KA, Ferrara N: Placenta growth factor. Potentiation of vascular endothelial growth factor bioactivity, in vitro and in vivo, and high affinity binding to Flt-1 but not to Flk-1/KDR. *J Biol Chem* 1994, 269(41):25646-25654.
106. Sawano A, Takahashi T, Yamaguchi S, Aonuma M, Shibuya M: Flt-1 but not KDR/Flk-1 tyrosine kinase is a receptor for placenta growth factor, which is related to vascular endothelial growth factor. *Cell Growth Differ* 1996, 7(2):213-221.
107. Kendall RL, Wang G, Thomas KA: Identification of a natural soluble form of the vascular endothelial growth factor receptor, FLT-1, and its heterodimerization with KDR. *Biochem Biophys Res Commun* 1996, 226(2):324-328.
108. Autiero M, Waltenberger J, Communi D, Kranz A, Moons L, Lambrechts D, Kroll J, Plaisance S, De Mol M, Bono F *et al*: Role of PlGF in the intra- and intermolecular cross talk between the VEGF receptors Flt1 and Flk1. *Nat Med* 2003, 9(7):936-943.

109. Yang W, Ahn H, Hinrichs M, Torry RJ, Torry DS: Evidence of a novel isoform of placenta growth factor (PlGF-4) expressed in human trophoblast and endothelial cells. *J Reprod Immunol* 2003, 60(1):53-60.
110. Maglione D, Guerriero V, Viglietto G, Ferraro MG, Aprelikova O, Alitalo K, Del Vecchio S, Lei KJ, Chou JY, Persico MG: Two alternative mRNAs coding for the angiogenic factor, placenta growth factor (PlGF), are transcribed from a single gene of chromosome 14. *Oncogene* 1993, 8(4):925-931.
111. Cao Y, Ji WR, Qi P, Rosin A: Placenta growth factor: identification and characterization of a novel isoform generated by RNA alternative splicing. *Biochem Biophys Res Commun* 1997, 235(3):493-498.
112. Hattori K, Heissig B, Wu Y, Dias S, Tejada R, Ferris B, Hicklin DJ, Zhu Z, Bohlen P, Witte L *et al*: Placental growth factor reconstitutes hematopoiesis by recruiting VEGFR1(+) stem cells from bone-marrow microenvironment. *Nat Med* 2002, 8(8):841-849.
113. Vuorela P, Hatva E, Lymboussaki A, Kaipainen A, Joukov V, Persico MG, Alitalo K, Halmesmaki E: Expression of vascular endothelial growth factor and placenta growth factor in human placenta. *Biol Reprod* 1997, 56(2):489-494.
114. Torry DS, Mukherjea D, Arroyo J, Torry RJ: Expression and function of placenta growth factor: implications for abnormal placentation. *J Soc Gynecol Investig* 2003, 10(4):178-188.
115. Eriksson U, Alitalo K: VEGF receptor 1 stimulates stem-cell recruitment and new hope for angiogenesis therapies. *Nat Med* 2002, 8(8):775-777.
116. Desai J, Holt-Shore V, Torry RJ, Caudle MR, Torry DS: Signal transduction and biological function of placenta growth factor in primary human trophoblast. *Biol Reprod* 1999, 60(4):887-892.
117. Hiratsuka S, Minowa O, Kuno J, Noda T, Shibuya M: Flt-1 lacking the tyrosine kinase domain is sufficient for normal development and angiogenesis in mice. *Proc Natl Acad Sci U S A* 1998, 95(16):9349-9354.
118. Tjwa M, Luttun A, Autiero M, Carmeliet P: VEGF and PlGF: two pleiotropic growth factors with distinct roles in development and homeostasis. *Cell Tissue Res* 2003, 314(1):5-14.
119. Carmeliet P, Moons L, Luttun A, Vincenti V, Compernelle V, De Mol M, Wu Y, Bono F, Devy L, Beck H *et al*: Synergism between vascular endothelial growth factor and placental growth factor contributes to angiogenesis and plasma extravasation in pathological conditions. *Nat Med* 2001, 7(5):575-583.
120. DiSalvo J, Bayne ML, Conn G, Kwok PW, Trivedi PG, Soderman DD, Palisi TM, Sullivan KA, Thomas KA: Purification and characterization of a naturally occurring vascular endothelial growth factor.placenta growth factor heterodimer. *J Biol Chem* 1995, 270(13):7717-7723.
121. Pipp F, Heil M, Issbrücker K, Ziegelhoeffer T, Martin S, van den Heuvel J, Weich H, Fernandez B, Golomb G, Carmeliet P *et al*: VEGFR-1-selective VEGF homologue PlGF is arteriogenic: evidence for a monocyte-mediated mechanism. *Circ Res* 2003, 92(4):378-385.
122. Clauss M, Weich H, Breier G, Knies U, Röckl W, Waltenberger J, Risau W: The vascular endothelial growth factor receptor Flt-1 mediates biological activities. Implications for a functional role of placenta growth factor in monocyte activation and chemotaxis. *J Biol Chem* 1996, 271(30):17629-17634.
123. Clark DE, Smith SK, Licence D, Evans AL, Charnock-Jones DS: Comparison of expression patterns for placenta growth factor, vascular endothelial growth factor

- (VEGF), VEGF-B and VEGF-C in the human placenta throughout gestation. *J Endocrinol* 1998, 159(3):459-467.
124. Khaliq A, Li XF, Shams M, Sisi P, Acevedo CA, Whittle MJ, Weich H, Ahmed A: Localisation of placenta growth factor (PlGF) in human term placenta. *Growth Factors* 1996, 13(3-4):243-250,color plates I-II,pre.bk cov.
 125. Levine RJ, Maynard SE, Qian C, Lim KH, England LJ, Yu KF, Schisterman EF, Thadhani R, Sachs BP, Epstein FH *et al*: Circulating angiogenic factors and the risk of preeclampsia. *N Engl J Med* 2004, 350(7):672-683.
 126. Levine RJ, Thadhani R, Qian C, Lam C, Lim KH, Yu KF, Blink AL, Sachs BP, Epstein FH, Sibai BM *et al*: Urinary placental growth factor and risk of preeclampsia. *JAMA* 2005, 293(1):77-85.
 127. Taylor RN, Grimwood J, Taylor RS, McMaster MT, Fisher SJ, North RA: Longitudinal serum concentrations of placental growth factor: evidence for abnormal placental angiogenesis in pathologic pregnancies. *Am J Obstet Gynecol* 2003, 188(1):177-182.
 128. Livingston JC, Chin R, Haddad B, McKinney ET, Ahokas R, Sibai BM: Reductions of vascular endothelial growth factor and placental growth factor concentrations in severe preeclampsia. *Am J Obstet Gynecol* 2000, 183(6):1554-1557.
 129. Chen CN, Hsieh FJ, Cheng YM, Cheng WF, Su YN, Chang KJ, Lee PH: The significance of placenta growth factor in angiogenesis and clinical outcome of human gastric cancer. *Cancer Lett* 2004, 213(1):73-82.
 130. Ho MC, Chen CN, Lee H, Hsieh FJ, Shun CT, Chang CL, Lai YT, Lee PH: Placenta growth factor not vascular endothelial growth factor A or C can predict the early recurrence after radical resection of hepatocellular carcinoma. *Cancer Lett* 2007, 250(2):237-249.
 131. Parr C, Watkins G, Boulton M, Cai J, Jiang WG: Placenta growth factor is over-expressed and has prognostic value in human breast cancer. *Eur J Cancer* 2005, 41(18):2819-2827.
 132. Failla CM, Odorisio T, Cianfarani F, Schietroma C, Puddu P, Zambruno G: Placenta growth factor is induced in human keratinocytes during wound healing. *J Invest Dermatol* 2000, 115(3):388-395.
 133. Oura H, Bertonecini J, Velasco P, Brown LF, Carmeliet P, Detmar M: A critical role of placental growth factor in the induction of inflammation and edema formation. *Blood* 2003, 101(2):560-567.
 134. Maes C, Coenegrachts L, Stockmans I, Daci E, Lutun A, Petryk A, Gopalakrishnan R, Moermans K, Smets N, Verfaillie CM *et al*: Placental growth factor mediates mesenchymal cell development, cartilage turnover, and bone remodeling during fracture repair. *J Clin Invest* 2006, 116(5):1230-1242.
 135. Perelman N, Selvaraj SK, Batra S, Luck LR, Erdreich-Epstein A, Coates TD, Kalra VK, Malik P: Placenta growth factor activates monocytes and correlates with sickle cell disease severity. *Blood* 2003, 102(4):1506-1514.
 136. Lutun A, Tjwa M, Moons L, Wu Y, Angelillo-Scherrer A, Liao F, Nagy JA, Hooper A, Priller J, De Klerck B *et al*: Revascularization of ischemic tissues by PlGF treatment, and inhibition of tumor angiogenesis, arthritis and atherosclerosis by anti-Flt1. *Nat Med* 2002, 8(8):831-840.
 137. Foley RN, Parfrey PS, Harnett JD, Kent GM, Martin CJ, Murray DC, Barre PE: Clinical and echocardiographic disease in patients starting end-stage renal disease therapy. *Kidney Int* 1995, 47(1):186-192.

138. Wald NJ, George L, Smith D, Densem JW, Petterson K: Serum screening for Down's syndrome between 8 and 14 weeks of pregnancy. International Prenatal Screening Research Group. *Br J Obstet Gynaecol* 1996, 103(5):407-412.
139. Boldt HB, Conover CA: Pregnancy-associated plasma protein-A (PAPP-A): a local regulator of IGF bioavailability through cleavage of IGFBPs. *Growth Horm IGF Res* 2007, 17(1):10-18.
140. Bergmann U, Tuuttila A, Stetler-Stevenson WG, Tryggvason K: Autolytic activation of recombinant human 72 kilodalton type IV collagenase. *Biochemistry* 1995, 34(9):2819-2825.
141. Laursen LS, Overgaard MT, Søe R, Boldt HB, Sottrup-Jensen L, Giudice LC, Conover CA, Oxvig C: Pregnancy-associated plasma protein-A (PAPP-A) cleaves insulin-like growth factor binding protein (IGFBP)-5 independent of IGF: implications for the mechanism of IGFBP-4 proteolysis by PAPP-A. *FEBS Lett* 2001, 504(1-2):36-40.
142. Lawrence JB, Oxvig C, Overgaard MT, Sottrup-Jensen L, Gleich GJ, Hays LG, Yates JR, Conover CA: The insulin-like growth factor (IGF)-dependent IGF binding protein-4 protease secreted by human fibroblasts is pregnancy-associated plasma protein-A. *Proc Natl Acad Sci U S A* 1999, 96(6):3149-3153.
143. Conover CA: Key questions and answers about pregnancy-associated plasma protein-A. *Trends Endocrinol Metab* 2012, 23(5):242-249.
144. Schindler AM, Bischof P: Histochemical localization of pregnancy-associated plasma protein A in fetal, infant, and adult organs and comparison between antisera. *Gynecol Obstet Invest* 1984, 18(2):88-94.
145. Overgaard MT, Oxvig C, Christiansen M, Lawrence JB, Conover CA, Gleich GJ, Sottrup-Jensen L, Haaning J: Messenger ribonucleic acid levels of pregnancy-associated plasma protein-A and the proform of eosinophil major basic protein: expression in human reproductive and nonreproductive tissues. *Biol Reprod* 1999, 61(4):1083-1089.
146. Bayes-Genis A, Conover CA, Overgaard MT, Bailey KR, Christiansen M, Holmes DR, Virmani R, Oxvig C, Schwartz RS: Pregnancy-associated plasma protein A as a marker of acute coronary syndromes. *N Engl J Med* 2001, 345(14):1022-1029.
147. Oxvig C, Sand O, Kristensen T, Gleich GJ, Sottrup-Jensen L: Circulating human pregnancy-associated plasma protein-A is disulfide-bridged to the proform of eosinophil major basic protein. *J Biol Chem* 1993, 268(17):12243-12246.
148. Renier G, Clément I, Desfaits AC, Lambert A: Direct stimulatory effect of insulin-like growth factor-I on monocyte and macrophage tumor necrosis factor-alpha production. *Endocrinology* 1996, 137(11):4611-4618.
149. Bayes-Genis A, Conover CA, Schwartz RS: The insulin-like growth factor axis: A review of atherosclerosis and restenosis. *Circ Res* 2000, 86(2):125-130.
150. Fialová L, Pilecková N, Bauer J, Soukupová J, Kalousová M, Malbohan I, Pernický A, Kraml P, Zima T: Pregnancy-associated plasma protein-A in patients with cerebrovascular diseases--a pilot study. *Prague Med Rep* 2006, 107(1):37-45.
151. Coskun A, Bicik Z, Duran S, Alcelik A, Soyupacaci Z, Yavuz O, Oksuz S: Pregnancy-associated plasma protein A in dialysis patients. *Clin Chem Lab Med* 2007, 45(1):63-66.
152. Kalousová M, Benáková H, Kuběna AA, Dusilová-Sulková S, Tesař V, Zima T: Pregnancy-associated plasma protein A as an independent mortality predictor in long-term haemodialysis patients. *Kidney Blood Press Res* 2012, 35(3):192-201.

153. Remacle AG, Rozanov DV, Fugere M, Day R, Strongin AY: Furin regulates the intracellular activation and the uptake rate of cell surface-associated MT1-MMP. *Oncogene* 2006, 25(41):5648-5655.
154. Nagase H, Woessner JF: Matrix metalloproteinases. *J Biol Chem* 1999, 274(31):21491-21494.
155. Nagase H, Visse R, Murphy G: Structure and function of matrix metalloproteinases and TIMPs. *Cardiovasc Res* 2006, 69(3):562-573.
156. Bode W, Gomis-Rüth FX, Stöckler W: Astacins, serralysins, snake venom and matrix metalloproteinases exhibit identical zinc-binding environments (HEXXHXXGXXH and Met-turn) and topologies and should be grouped into a common family, the 'metzincins'. *FEBS Lett* 1993, 331(1-2):134-140.
157. Aimes RT, Quigley JP: Matrix metalloproteinase-2 is an interstitial collagenase. Inhibitor-free enzyme catalyzes the cleavage of collagen fibrils and soluble native type I collagen generating the specific 3/4- and 1/4-length fragments. *J Biol Chem* 1995, 270(11):5872-5876.
158. Patterson ML, Atkinson SJ, Knäuper V, Murphy G: Specific collagenolysis by gelatinase A, MMP-2, is determined by the hemopexin domain and not the fibronectin-like domain. *FEBS Lett* 2001, 503(2-3):158-162.
159. Strickland DK, Ashcom JD, Williams S, Burgess WH, Migliorini M, Argraves WS: Sequence identity between the alpha 2-macroglobulin receptor and low density lipoprotein receptor-related protein suggests that this molecule is a multifunctional receptor. *J Biol Chem* 1990, 265(29):17401-17404.
160. Arthur MJ: Fibrosis and altered matrix degradation. *Digestion* 1998, 59(4):376-380.
161. Lenz O, Elliot SJ, Stetler-Stevenson WG: Matrix metalloproteinases in renal development and disease. *J Am Soc Nephrol* 2000, 11(3):574-581.
162. Singhal PC, Sagar S, Garg P: Simulated glomerular pressure modulates mesangial cell 72 kDa metalloproteinase activity. *Connect Tissue Res* 1996, 33(4):257-263.
163. Akiyama K, Shikata K, Sugimoto H, Matsuda M, Shikata Y, Fujimoto N, Obata K, Matsui H, Makino H: Changes in serum concentrations of matrix metalloproteinases, tissue inhibitors of metalloproteinases and type IV collagen in patients with various types of glomerulonephritis. *Res Commun Mol Pathol Pharmacol* 1997, 95(2):115-128.
164. Catania JM, Chen G, Parrish AR: Role of matrix metalloproteinases in renal pathophysiology. *Am J Physiol Renal Physiol* 2007, 292(3):F905-911.
165. El-Nahas AM: Plasticity of kidney cells: role in kidney remodeling and scarring. *Kidney Int* 2003, 64(5):1553-1563.
166. Galis ZS, Khatri JJ: Matrix metalloproteinases in vascular remodeling and atherogenesis: the good, the bad, and the ugly. *Circ Res* 2002, 90(3):251-262.
167. Chang HR, Yang SF, Li ML, Lin CC, Hsieh YS, Lian JD: Relationships between circulating matrix metalloproteinase-2 and -9 and renal function in patients with chronic kidney disease. *Clin Chim Acta* 2006, 366(1-2):243-248.
168. Endo T, Nakabayashi K, Sekiuchi M, Kuroda T, Soejima A, Yamada A: Matrix metalloproteinase-2, matrix metalloproteinase-9, and tissue inhibitor of metalloproteinase-1 in the peripheral blood of patients with various glomerular diseases and their implication in pathogenetic lesions: study based on an enzyme-linked assay and immunohistochemical staining. *Clin Exp Nephrol* 2006, 10(4):253-261.
169. Nagano M, Fukami K, Yamagishi S, Ueda S, Kaida Y, Matsumoto T, Yoshimura J, Hazama T, Takamiya Y, Kusumoto T *et al*: Circulating matrix metalloproteinase-2 is

- an independent correlate of proteinuria in patients with chronic kidney disease. *Am J Nephrol* 2009, 29(2):109-115.
170. Inokubo Y, Hanada H, Ishizaka H, Fukushi T, Kamada T, Okumura K: Plasma levels of matrix metalloproteinase-9 and tissue inhibitor of metalloproteinase-1 are increased in the coronary circulation in patients with acute coronary syndrome. *Am Heart J* 2001, 141(2):211-217.
 171. Urushihara M, Kagami S, Kuhara T, Tamaki T, Kuroda Y: Glomerular distribution and gelatinolytic activity of matrix metalloproteinases in human glomerulonephritis. *Nephrol Dial Transplant* 2002, 17(7):1189-1196.
 172. Bauvois B, Mothu N, Nguyen J, Nguyen-Khoa T, Noël LH, Jungers P: Specific changes in plasma concentrations of matrix metalloproteinase-2 and -9, TIMP-1 and TGF-beta1 in patients with distinct types of primary glomerulonephritis. *Nephrol Dial Transplant* 2007, 22(4):1115-1122.
 173. Mahajan N, Malik N, Bahl A, Dhawan V: Receptor for advanced glycation end products (RAGE) and its inflammatory ligand EN-RAGE in non-diabetic subjects with pre-mature coronary artery disease. *Atherosclerosis* 2009, 207(2):597-602.
 174. Park S, Yoon SJ, Tae HJ, Shim CY: RAGE and cardiovascular disease. *Front Biosci* 2011, 16:486-497.
 175. Schmidt AM, Yan SD, Yan SF, Stern DM: The multiligand receptor RAGE as a progression factor amplifying immune and inflammatory responses. *J Clin Invest* 2001, 108(7):949-955.
 176. Goldin A, Beckman JA, Schmidt AM, Creager MA: Advanced glycation end products: sparking the development of diabetic vascular injury. *Circulation* 2006, 114(6):597-605.
 177. Basta G, Lazzerini G, Massaro M, Simoncini T, Tanganelli P, Fu C, Kislinger T, Stern DM, Schmidt AM, De Caterina R: Advanced glycation end products activate endothelium through signal-transduction receptor RAGE: a mechanism for amplification of inflammatory responses. *Circulation* 2002, 105(7):816-822.
 178. Schmidt AM, Yan SD, Yan SF, Stern DM: The biology of the receptor for advanced glycation end products and its ligands. *Biochim Biophys Acta* 2000, 1498(2-3):99-111.
 179. Santilli F, Vazzana N, Bucciarelli LG, Davì G: Soluble forms of RAGE in human diseases: clinical and therapeutical implications. *Curr Med Chem* 2009, 16(8):940-952.
 180. Kalousová M, Hodková M, Kazderová M, Fialová J, Tesar V, Dusilová-Sulková S, Zima T: Soluble receptor for advanced glycation end products in patients with decreased renal function. *Am J Kidney Dis* 2006, 47(3):406-411.
 181. Basta G, Leonardis D, Mallamaci F, Cutrupi S, Pizzini P, Gaetano L, Tripepi R, Tripepi G, De Caterina R, Zoccali C: Circulating soluble receptor of advanced glycation end product inversely correlates with atherosclerosis in patients with chronic kidney disease. *Kidney Int* 2010, 77(3):225-231.
 182. Schlueter C, Hauke S, Flohr AM, Rogalla P, Bullerdiek J: Tissue-specific expression patterns of the RAGE receptor and its soluble forms--a result of regulated alternative splicing? *Biochim Biophys Acta* 2003, 1630(1):1-6.
 183. Raucci A, Cugusi S, Antonelli A, Barabino SM, Monti L, Bierhaus A, Reiss K, Saftig P, Bianchi ME: A soluble form of the receptor for advanced glycation endproducts (RAGE) is produced by proteolytic cleavage of the membrane-bound form by the sheddase a disintegrin and metalloprotease 10 (ADAM10). *FASEB J* 2008, 22(10):3716-3727.
 184. Zhang L, Bukulin M, Kojro E, Roth A, Metz VV, Fahrenholz F, Nawroth PP, Bierhaus A, Postina R: Receptor for advanced glycation end products is subjected to

- protein ectodomain shedding by metalloproteinases. *J Biol Chem* 2008, 283(51):35507-35516.
185. Parkin E, Harris B: A disintegrin and metalloproteinase (ADAM)-mediated ectodomain shedding of ADAM10. *J Neurochem* 2009, 108(6):1464-1479.
 186. Hudson BI, Carter AM, Harja E, Kalea AZ, Arriero M, Yang H, Grant PJ, Schmidt AM: Identification, classification, and expression of RAGE gene splice variants. *FASEB J* 2008, 22(5):1572-1580.
 187. Basta G, Sironi AM, Lazzerini G, Del Turco S, Buzzigoli E, Casolaro A, Natali A, Ferrannini E, Gastaldelli A: Circulating soluble receptor for advanced glycation end products is inversely associated with glycemic control and S100A12 protein. *J Clin Endocrinol Metab* 2006, 91(11):4628-4634.
 188. Vazzana N, Santilli F, Cuccurullo C, Davì G: Soluble forms of RAGE in internal medicine. *Intern Emerg Med* 2009, 4(5):389-401.
 189. Vallee BL, Auld DS: Zinc: biological function and coordination motifs. In., vol. 26: *Acc. Chem. Res.*; 1993: 543-555.
 190. Kretsinger RH: Structure and evolution of calcium-modulated proteins. *CRC Crit Rev Biochem* 1980, 8(2):119-174.
 191. Fuellen G, Foell D, Nacken W, Sorg C, Kerkhoff C: Absence of S100A12 in mouse: implications for RAGE-S100A12 interaction. *Trends Immunol* 2003, 24(12):622-624.
 192. Robinson MJ, Hogg N: A comparison of human S100A12 with MRP-14 (S100A9). *Biochem Biophys Res Commun* 2000, 275(3):865-870.
 193. Yang Z, Tao T, Raftery MJ, Youssef P, Di Girolamo N, Geczy CL: Proinflammatory properties of the human S100 protein S100A12. *J Leukoc Biol* 2001, 69(6):986-994.
 194. Vogl T, Pröpper C, Hartmann M, Strey A, Strupat K, van den Bos C, Sorg C, Roth J: S100A12 is expressed exclusively by granulocytes and acts independently from MRP8 and MRP14. *J Biol Chem* 1999, 274(36):25291-25296.
 195. Foell D, Wittkowski H, Vogl T, Roth J: S100 proteins expressed in phagocytes: a novel group of damage-associated molecular pattern molecules. *J Leukoc Biol* 2007, 81(1):28-37.
 196. Hofmann MA, Drury S, Fu C, Qu W, Taguchi A, Lu Y, Avila C, Kambham N, Bierhaus A, Nawroth P *et al*: RAGE mediates a novel proinflammatory axis: a central cell surface receptor for S100/calgranulin polypeptides. *Cell* 1999, 97(7):889-901.
 197. Neish AS, Williams AJ, Palmer HJ, Whitley MZ, Collins T: Functional analysis of the human vascular cell adhesion molecule 1 promoter. *J Exp Med* 1992, 176(6):1583-1593.
 198. Miranda LP, Tao T, Jones A, Chernushevich I, Standing KG, Geczy CL, Alewood PF: Total chemical synthesis and chemotactic activity of human S100A12 (EN-RAGE). *FEBS Lett* 2001, 488(1-2):85-90.
 199. Kessel C, Holzinger D, Foell D: Phagocyte-derived S100 proteins in autoinflammation: Putative role in pathogenesis and usefulness as biomarkers. *Clin Immunol* 2013, 147(3):229-241.
 200. Nakashima A, Carrero JJ, Qureshi AR, Miyamoto T, Anderstam B, Bárány P, Heimbürger O, Stenvinkel P, Lindholm B: Effect of circulating soluble receptor for advanced glycation end products (sRAGE) and the proinflammatory RAGE ligand (EN-RAGE, S100A12) on mortality in haemodialysis patients. *Clin J Am Soc Nephrol* 2010, 5(12):2213-2219.
 201. Shiotsu Y, Mori Y, Nishimura M, Sakoda C, Tokoro T, Hatta T, Maki N, Iida K, Iwamoto N, Ono T *et al*: Plasma S100A12 level is associated with cardiovascular disease in haemodialysis patients. *Clin J Am Soc Nephrol* 2011, 6(4):718-723.

202. Goodwin GH, Sanders C, Johns EW: A new group of chromatin-associated proteins with a high content of acidic and basic amino acids. *Eur J Biochem* 1973, 38(1):14-19.
203. Bonaldi T, Talamo F, Scaffidi P, Ferrera D, Porto A, Bachi A, Rubartelli A, Agresti A, Bianchi ME: Monocytic cells hyperacetylate chromatin protein HMGB-1 to redirect it towards secretion. *EMBO J* 2003, 22(20):5551-5560.
204. Weir HM, Kraulis PJ, Hill CS, Raine AR, Laue ED, Thomas JO: Structure of the HMG box motif in the B-domain of HMG1. *EMBO J* 1993, 12(4):1311-1319.
205. Li J, Kokkola R, Tabibzadeh S, Yang R, Ochani M, Qiang X, Harris HE, Czura CJ, Wang H, Ulloa L *et al*: Structural basis for the proinflammatory cytokine activity of high mobility group box 1. *Mol Med* 2003, 9(1-2):37-45.
206. Messmer D, Yang H, Telusma G, Knoll F, Li J, Messmer B, Tracey KJ, Chiorazzi N: High mobility group box protein 1: an endogenous signal for dendritic cell maturation and Th1 polarization. *J Immunol* 2004, 173(1):307-313.
207. Yang H, Ochani M, Li J, Qiang X, Tanovic M, Harris HE, Susarla SM, Ulloa L, Wang H, DiRaimo R *et al*: Reversing established sepsis with antagonists of endogenous high-mobility group box 1. *Proc Natl Acad Sci U S A* 2004, 101(1):296-301.
208. Scaffidi P, Misteli T, Bianchi ME: Release of chromatin protein HMGB-1 by necrotic cells triggers inflammation. *Nature* 2002, 418(6894):191-195.
209. Wang H, Bloom O, Zhang M, Vishnubhakat JM, Ombrellino M, Che J, Frazier A, Yang H, Ivanova S, Borovikova L *et al*: HMGB-1 as a late mediator of endotoxin lethality in mice. *Science* 1999, 285(5425):248-251.
210. Lotze MT, Tracey KJ: High-mobility group box 1 protein (HMGB-1): nuclear weapon in the immune arsenal. *Nat Rev Immunol* 2005, 5(4):331-342.
211. Abraham E, Arcaroli J, Carmody A, Wang H, Tracey KJ: HMGB-1 as a mediator of acute lung inflammation. *J Immunol* 2000, 165(6):2950-2954.
212. Palumbo R, Galvez BG, Pusterla T, De Marchis F, Cossu G, Marcu KB, Bianchi ME: Cells migrating to sites of tissue damage in response to the danger signal HMGB-1 require NF-kappaB activation. *J Cell Biol* 2007, 179(1):33-40.
213. Park JS, Arcaroli J, Yum HK, Yang H, Wang H, Yang KY, Choe KH, Strassheim D, Pitts TM, Tracey KJ *et al*: Activation of gene expression in human neutrophils by high mobility group box 1 protein. *Am J Physiol Cell Physiol* 2003, 284(4):C870-879.
214. Dumitriu IE, Baruah P, Valentinis B, Voll RE, Herrmann M, Nawroth PP, Arnold B, Bianchi ME, Manfredi AA, Rovere-Querini P: Release of high mobility group box 1 by dendritic cells controls T cell activation via the receptor for advanced glycation end products. *J Immunol* 2005, 174(12):7506-7515.
215. Yang D, Chen Q, Yang H, Tracey KJ, Bustin M, Oppenheim JJ: High mobility group box-1 protein induces the migration and activation of human dendritic cells and acts as an alarmin. *J Leukoc Biol* 2007, 81(1):59-66.
216. Rouhiainen A, Kuja-Panula J, Wilkman E, Pakkanen J, Stenfors J, Tuominen RK, Lepäntalo M, Carpén O, Parkkinen J, Rauvala H: Regulation of monocyte migration by amphotericin (HMGB-1). *Blood* 2004, 104(4):1174-1182.
217. Orlova VV, Choi EY, Xie C, Chavakis E, Bierhaus A, Ihanus E, Ballantyne CM, Gahmberg CG, Bianchi ME, Nawroth PP *et al*: A novel pathway of HMGB-1-mediated inflammatory cell recruitment that requires Mac-1-integrin. *EMBO J* 2007, 26(4):1129-1139.
218. Fiuza C, Bustin M, Talwar S, Tropea M, Gerstenberger E, Shelhamer JH, Suffredini AF: Inflammation-promoting activity of HMGB-1 on human microvascular endothelial cells. *Blood* 2003, 101(7):2652-2660.

219. Treutiger CJ, Mullins GE, Johansson AS, Rouhiainen A, Rauvala HM, Erlandsson-Harris H, Andersson U, Yang H, Tracey KJ, Andersson J *et al*: High mobility group 1 B-box mediates activation of human endothelium. *J Intern Med* 2003, 254(4):375-385.
220. Kokkola R, Andersson A, Mullins G, Ostberg T, Treutiger CJ, Arnold B, Nawroth P, Andersson U, Harris RA, Harris HE: RAGE is the major receptor for the proinflammatory activity of HMGB-1 in rodent macrophages. *Scand J Immunol* 2005, 61(1):1-9.
221. Park JS, Svetkauskaite D, He Q, Kim JY, Strassheim D, Ishizaka A, Abraham E: Involvement of toll-like receptors 2 and 4 in cellular activation by high mobility group box 1 protein. *J Biol Chem* 2004, 279(9):7370-7377.
222. Ito T, Kawahara K, Nakamura T, Yamada S, Abeyama K, Hashiguchi T, Maruyama I: High-mobility group box 1 protein promotes development of microvascular thrombosis in rats. *J Thromb Haemost* 2007, 5(1):109-116.
223. Ueno H, Matsuda T, Hashimoto S, Amaya F, Kitamura Y, Tanaka M, Kobayashi A, Maruyama I, Yamada S, Hasegawa N *et al*: Contributions of high mobility group box protein in experimental and clinical acute lung injury. *Am J Respir Crit Care Med* 2004, 170(12):1310-1316.
224. Taniguchi N, Kawahara K, Yone K, Hashiguchi T, Yamakuchi M, Goto M, Inoue K, Yamada S, Ijiri K, Matsunaga S *et al*: High mobility group box chromosomal protein 1 plays a role in the pathogenesis of rheumatoid arthritis as a novel cytokine. *Arthritis Rheum* 2003, 48(4):971-981.
225. Inoue K, Kawahara K, Biswas KK, Ando K, Mitsudo K, Nobuyoshi M, Maruyama I: HMGB-1 expression by activated vascular smooth muscle cells in advanced human atherosclerosis plaques. *Cardiovasc Pathol* 2007, 16(3):136-143.
226. Kalinina N, Agrotis A, Antropova Y, DiVitto G, Kanellakis P, Kostolias G, Ilyinskaya O, Tararak E, Bobik A: Increased expression of the DNA-binding cytokine HMGB-1 in human atherosclerotic lesions: role of activated macrophages and cytokines. *Arterioscler Thromb Vasc Biol* 2004, 24(12):2320-2325.
227. Tsung A, Sahai R, Tanaka H, Nakao A, Fink MP, Lotze MT, Yang H, Li J, Tracey KJ, Geller DA *et al*: The nuclear factor HMGB-1 mediates hepatic injury after murine liver ischemia-reperfusion. *J Exp Med* 2005, 201(7):1135-1143.
228. Andrassy M, Volz HC, Igwe JC, Funke B, Eichberger SN, Kaya Z, Buss S, Autschbach F, Pleger ST, Lukic IK *et al*: High-mobility group box-1 in ischemia-reperfusion injury of the heart. *Circulation* 2008, 117(25):3216-3226.
229. Bruchfeld A, Qureshi AR, Lindholm B, Barany P, Yang L, Stenvinkel P, Tracey KJ: High Mobility Group Box Protein-1 correlates with renal function in chronic kidney disease (CKD). *Mol Med* 2008, 14(3-4):109-115.
230. Newman DJ, Thakkar H, Edwards RG, Wilkie M, White T, Grubb AO, Price CP: Serum cystatin C measured by automated immunoassay: a more sensitive marker of changes in GFR than serum creatinine. *Kidney Int* 1995, 47(1):312-318.
231. Hoffmann A, Nimtz M, Conradt HS: Molecular characterization of beta-trace protein in human serum and urine: a potential diagnostic marker for renal diseases. *Glycobiology* 1997, 7(4):499-506.
232. Feig DI: Uric acid: a novel mediator and marker of risk in chronic kidney disease? *Curr Opin Nephrol Hypertens* 2009, 18(6):526-530.
233. Ix JH, Shlipak MG, Chertow GM, Whooley MA: Association of cystatin C with mortality, cardiovascular events, and incident heart failure among persons with coronary heart disease: data from the Heart and Soul Study. *Circulation* 2007, 115(2):173-179.

234. Malyszko J, Malyszko JS, Bachorzewska-Gajewska H, Poniatowski B, Dobrzycki S, Mysliwiec M: Neutrophil gelatinase-associated lipocalin is a new and sensitive marker of kidney function in chronic kidney disease patients and renal allograft recipients. *Transplant Proc* 2009, 41(1):158-161.
235. Ko GJ, Grigoryev DN, Linfert D, Jang HR, Watkins T, Cheadle C, Racusen L, Rabb H: Transcriptional analysis of kidneys during repair from AKI reveals possible roles for NGAL and KIM-1 as biomarkers of AKI-to-CKD transition. *Am J Physiol Renal Physiol* 2010, 298(6):F1472-1483.
236. Bosomworth MP, Aparicio SR, Hay AW: Urine N-acetyl-beta-D-glucosaminidase--a marker of tubular damage? *Nephrol Dial Transplant* 1999, 14(3):620-626.
237. Kamijo A, Sugaya T, Hikawa A, Yamanouchi M, Hirata Y, Ishimitsu T, Numabe A, Takagi M, Hayakawa H, Tabei F *et al*: Urinary liver-type fatty acid binding protein as a useful biomarker in chronic kidney disease. *Mol Cell Biochem* 2006, 284(1-2):175-182.
238. Hörstrup JH, Gehrmann M, Schneider B, Plöger A, Froese P, Schirop T, Kampf D, Frei U, Neumann R, Eckardt KU: Elevation of serum and urine levels of TIMP-1 and tenascin in patients with renal disease. *Nephrol Dial Transplant* 2002, 17(6):1005-1013.
239. Wang G, Lai FM, Lai KB, Chow KM, Li KT, Szeto CC: Messenger RNA expression of podocyte-associated molecules in the urinary sediment of patients with diabetic nephropathy. *Nephron Clin Pract* 2007, 106(4):c169-179.
240. Wang G, Lai FM, Tam LS, Li KM, Lai KB, Chow KM, Li KT, Szeto CC: Messenger RNA expression of podocyte-associated molecules in urinary sediment of patients with lupus nephritis. *J Rheumatol* 2007, 34(12):2358-2364.
241. Mori K, Nakao K: Neutrophil gelatinase-associated lipocalin as the real-time indicator of active kidney damage. *Kidney Int* 2007, 71(10):967-970.
242. Ravani P, Tripepi G, Malberti F, Testa S, Mallamaci F, Zoccali C: Asymmetrical dimethylarginine predicts progression to dialysis and death in patients with chronic kidney disease: a competing risks modeling approach. *J Am Soc Nephrol* 2005, 16(8):2449-2455.
243. Vesely DL: Atrial natriuretic peptides in pathophysiological diseases. *Cardiovasc Res* 2001, 51(4):647-658.
244. Bunton DC, Petrie MC, Hillier C, Johnston F, McMurray JJ: The clinical relevance of adrenomedullin: a promising profile? *Pharmacol Ther* 2004, 103(3):179-201.
245. Sakuma M, Nakamura M, Tanaka F, Onoda T, Itai K, Tanno K, Ohsawa M, Sakata K, Yoshida Y, Kawamura K *et al*: Plasma B-type natriuretic peptide level and cardiovascular events in chronic kidney disease in a community-based population. *Circ J* 2010, 74(4):792-797.
246. Zoccali C, Bode-Böger S, Mallamaci F, Benedetto F, Tripepi G, Malatino L, Cataliotti A, Bellanuova I, Fermo I, Frölich J *et al*: Plasma concentration of asymmetrical dimethylarginine and mortality in patients with end-stage renal disease: a prospective study. *Lancet* 2001, 358(9299):2113-2117.
247. Shlipak MG, Fried LF, Crump C, Bleyer AJ, Manolio TA, Tracy RP, Furberg CD, Psaty BM: Elevations of inflammatory and procoagulant biomarkers in elderly persons with renal insufficiency. *Circulation* 2003, 107(1):87-92.
248. Pereira BJ, Shapiro L, King AJ, Falagas ME, Strom JA, Dinarello CA: Plasma levels of IL-1 beta, TNF alpha and their specific inhibitors in undialyzed chronic renal failure, CAPD and haemodialysis patients. *Kidney Int* 1994, 45(3):890-896.
249. Tong M, Carrero JJ, Qureshi AR, Anderstam B, Heimbürger O, Bárány P, Axelsson J, Alvestrand A, Stenvinkel P, Lindholm B *et al*: Plasma pentraxin 3 in patients with

- chronic kidney disease: associations with renal function, protein-energy wasting, cardiovascular disease, and mortality. *Clin J Am Soc Nephrol* 2007, 2(5):889-897.
250. Miyauchi K, Takiyama Y, Honjyo J, Tateno M, Haneda M: Upregulated IL-18 expression in type 2 diabetic subjects with nephropathy: TGF-beta1 enhanced IL-18 expression in human renal proximal tubular epithelial cells. *Diabetes Res Clin Pract* 2009, 83(2):190-199.
 251. Basile DP: The transforming growth factor beta system in kidney disease and repair: recent progress and future directions. *Curr Opin Nephrol Hypertens* 1999, 8(1):21-30.
 252. Zhou J, Ouyang X, Cui X, Schoeb TR, Smythies LE, Johnson MR, Guay-Woodford LM, Chapman AB, Mrug M: Renal CD14 expression correlates with the progression of cystic kidney disease. *Kidney Int* 2010, 78(6):550-560.
 253. Westerberg PA, Linde T, Wikström B, Ljunggren O, Stridsberg M, Larsson TE: Regulation of fibroblast growth factor-23 in chronic kidney disease. *Nephrol Dial Transplant* 2007, 22(11):3202-3207.
 254. Kronenberg F, Kuen E, Ritz E, König P, Kraatz G, Lhotta K, Mann JF, Müller GA, Neyer U, Riegel W *et al*: Apolipoprotein A-IV serum concentrations are elevated in patients with mild and moderate renal failure. *J Am Soc Nephrol* 2002, 13(2):461-469.
 255. Zoccali C, Mallamaci F, Panuccio V, Tripepi G, Cutrupi S, Parlongo S, Catalano F, Tanaka S, Ouchi N, Kihara S *et al*: Adiponectin is markedly increased in patients with nephrotic syndrome and is related to metabolic risk factors. *Kidney Int Suppl* 2003(84):S98-102.
 256. Seiler S, Reichart B, Roth D, Seibert E, Fliser D, Heine GH: FGF-23 and future cardiovascular events in patients with chronic kidney disease before initiation of dialysis treatment. *Nephrol Dial Transplant* 2010, 25(12):3983-3989.
 257. Mishra J, Dent C, Tarabishi R, Mitsnefes MM, Ma Q, Kelly C, Ruff SM, Zahedi K, Shao M, Bean J *et al*: Neutrophil gelatinase-associated lipocalin (NGAL) as a biomarker for acute renal injury after cardiac surgery. *Lancet* 2005, 365(9466):1231-1238.
 258. Wagener G, Gubitosa G, Wang S, Borregaard N, Kim M, Lee HT: Urinary neutrophil gelatinase-associated lipocalin and acute kidney injury after cardiac surgery. *Am J Kidney Dis* 2008, 52(3):425-433.
 259. Vaidya VS, Ramirez V, Ichimura T, Bobadilla NA, Bonventre JV: Urinary kidney injury molecule-1: a sensitive quantitative biomarker for early detection of kidney tubular injury. *Am J Physiol Renal Physiol* 2006, 290(2):F517-529.
 260. Han WK, Bailly V, Abichandani R, Thadhani R, Bonventre JV: Kidney Injury Molecule-1 (KIM-1): a novel biomarker for human renal proximal tubule injury. *Kidney Int* 2002, 62(1):237-244.
 261. Wu H, Craft ML, Wang P, Wyburn KR, Chen G, Ma J, Hambly B, Chadban SJ: IL-18 contributes to renal damage after ischemia-reperfusion. *J Am Soc Nephrol* 2008, 19(12):2331-2341.
 262. Melnikov VY, Ecdar T, Fantuzzi G, Siegmund B, Lucia MS, Dinarello CA, Schrier RW, Edelstein CL: Impaired IL-18 processing protects caspase-1-deficient mice from ischemic acute renal failure. *J Clin Invest* 2001, 107(9):1145-1152.
 263. Wiley RA, Choo HY, Traiger GJ: The effect of nephrotoxic furans on urinary N-acetylglucosaminidase levels in mice. *Toxicol Lett* 1982, 14(1-2):93-96.
 264. Negishi K, Noiri E, Doi K, Maeda-Mamiya R, Sugaya T, Portilla D, Fujita T: Monitoring of urinary L-type fatty acid-binding protein predicts histological severity of acute kidney injury. *Am J Pathol* 2009, 174(4):1154-1159.
 265. Pelsers MM: Fatty acid-binding protein as marker for renal injury. *Scand J Clin Lab Invest Suppl* 2008, 241:73-77.

266. Reeves WB, Kwon O, Ramesh G: Netrin-1 and kidney injury. II. Netrin-1 is an early biomarker of acute kidney injury. *Am J Physiol Renal Physiol* 2008, 294(4):F731-738.
267. Rice JC, Spence JS, Yetman DL, Safirstein RL: Monocyte chemoattractant protein-1 expression correlates with monocyte infiltration in the post-ischemic kidney. *Ren Fail* 2002, 24(6):703-723.
268. Butler WT: The nature and significance of osteopontin. *Connect Tissue Res* 1989, 23(2-3):123-136.
269. Xie Y, Sakatsume M, Nishi S, Narita I, Arakawa M, Gejyo F: Expression, roles, receptors, and regulation of osteopontin in the kidney. *Kidney Int* 2001, 60(5):1645-1657.
270. Coca SG, Yalavarthy R, Concato J, Parikh CR: Biomarkers for the diagnosis and risk stratification of acute kidney injury: a systematic review. *Kidney Int* 2008, 73(9):1008-1016.
271. Levey AS, Bosch JP, Lewis JB, Greene T, Rogers N, Roth D: A more accurate method to estimate glomerular filtration rate from serum creatinine: a new prediction equation. Modification of Diet in Renal Disease Study Group. *Ann Intern Med* 1999, 130(6):461-470.
272. Papayianni A, Alexopoulos E, Giamalis P, Gionanlis L, Belechri AM, Koukoudis P, Memmos D: Circulating levels of ICAM-1, VCAM-1, and MCP-1 are increased in haemodialysis patients: association with inflammation, dyslipidaemia, and vascular events. *Nephrol Dial Transplant* 2002, 17(3):435-441.
273. Tzoulaki I, Murray GD, Lee AJ, Rumley A, Lowe GD, Fowkes FG: C-reactive protein, interleukin-6, and soluble adhesion molecules as predictors of progressive peripheral atherosclerosis in the general population: Edinburgh Artery Study. *Circulation* 2005, 112(7):976-983.
274. Annuk M, Soveri I, Zilmer M, Lind L, Hulthe J, Fellström B: Endothelial function, CRP and oxidative stress in chronic kidney disease. *J Nephrol* 2005, 18(6):721-726.
275. Oberg BP, McMenamin E, Lucas FL, McMonagle E, Morrow J, Ikizler TA, Himmelfarb J: Increased prevalence of oxidant stress and inflammation in patients with moderate to severe chronic kidney disease. *Kidney Int* 2004, 65(3):1009-1016.
276. Yilmaz MI, Saglam M, Caglar K, Cakir E, Sonmez A, Ozgurtas T, Aydin A, Eyileten T, Ozcan O, Acikel C *et al*: The determinants of endothelial dysfunction in CKD: oxidative stress and asymmetric dimethylarginine. *Am J Kidney Dis* 2006, 47(1):42-50.
277. Brown LF, Berse B, Tognazzi K, Manseau EJ, Van de Water L, Senger DR, Dvorak HF, Rosen S: Vascular permeability factor mRNA and protein expression in human kidney. *Kidney Int* 1992, 42(6):1457-1461.
278. Simon M, Gröne HJ, Jöhren O, Kullmer J, Plate KH, Risau W, Fuchs E: Expression of vascular endothelial growth factor and its receptors in human renal ontogenesis and in adult kidney. *Am J Physiol* 1995, 268(2 Pt 2):F240-250.
279. Torry DS, Wang HS, Wang TH, Caudle MR, Torry RJ: Preeclampsia is associated with reduced serum levels of placenta growth factor. *Am J Obstet Gynecol* 1998, 179(6 Pt 1):1539-1544.
280. Ziche M, Maglione D, Ribatti D, Morbidelli L, Lago CT, Battisti M, Paoletti I, Barra A, Tucci M, Parise G *et al*: Placenta growth factor-1 is chemotactic, mitogenic, and angiogenic. *Lab Invest* 1997, 76(4):517-531.
281. Khurana R, Moons L, Shafi S, Luttun A, Collen D, Martin JF, Carmeliet P, Zachary IC: Placental growth factor promotes atherosclerotic intimal thickening and macrophage accumulation. *Circulation* 2005, 111(21):2828-2836.

282. Onoue K, Uemura S, Takeda Y, Somekawa S, Iwama H, Imagawa K, Nishida T, Morikawa Y, Takemoto Y, Asai O *et al*: Reduction of circulating soluble fms-like tyrosine kinase-1 plays a significant role in renal dysfunction-associated aggravation of atherosclerosis. *Circulation* 2009, 120(24):2470-2477.
283. Tarnow L, Astrup AS, Parving HH: Elevated placental growth factor (PIGF) predicts cardiovascular morbidity and mortality in type 1 diabetic patients with diabetic nephropathy. *Scand J Clin Lab Invest Suppl* 2005, 240:73-79.
284. Cassidy A, Chiuve SE, Manson JE, Rexrode KM, Girman CJ, Rimm EB: Potential role for plasma placental growth factor in predicting coronary heart disease risk in women. *Arterioscler Thromb Vasc Biol* 2009, 29(1):134-139.
285. Apple FS, Wu AH, Mair J, Ravkilde J, Panteghini M, Tate J, Pagani F, Christenson RH, Mockel M, Danne O *et al*: Future biomarkers for detection of ischemia and risk stratification in acute coronary syndrome. *Clin Chem* 2005, 51(5):810-824.
286. Cheung AK: Quantitation of dialysis. The importance of membrane and middle molecules. *Blood Purif* 1994, 12(1):42-53.
287. Yano K, Liaw PC, Mullington JM, Shih SC, Okada H, Bodyak N, Kang PM, Toltl L, Belikoff B, Buras J *et al*: Vascular endothelial growth factor is an important determinant of sepsis morbidity and mortality. *J Exp Med* 2006, 203(6):1447-1458.
288. Bonetti PO, Lerman LO, Napoli C, Lerman A: Statin effects beyond lipid lowering--are they clinically relevant? *Eur Heart J* 2003, 24(3):225-248.
289. Ray KK, Cannon CP: Intensive statin therapy in acute coronary syndromes: clinical benefits and vascular biology. *Curr Opin Lipidol* 2004, 15(6):637-643.
290. Kodama Y, Kitta Y, Nakamura T, Takano H, Umetani K, Fujioka D, Saito Y, Kawabata K, Obata JE, Mende A *et al*: Atorvastatin increases plasma soluble Fms-like tyrosine kinase-1 and decreases vascular endothelial growth factor and placental growth factor in association with improvement of ventricular function in acute myocardial infarction. *J Am Coll Cardiol* 2006, 48(1):43-50.
291. Mori Y, Kosaki A, Kishimoto N, Kimura T, Iida K, Fukui M, Nakajima F, Nagahara M, Urakami M, Iwasaka T *et al*: Increased plasma S100A12 (EN-RAGE) levels in haemodialysis patients with atherosclerosis. *Am J Nephrol* 2009, 29(1):18-24.
292. Uchiyama-Tanaka Y, Mori Y, Kosaki A, Kimura T, Moriishi M, Kawanishi H, Matsubara H: Plasma S100A12 concentrations in peritoneal dialysis patients and subclinical chronic inflammatory disease. *Ther Apher Dial* 2008, 12(1):28-32.
293. Kalousová M, Jáchymová M, Mestek O, Hodková M, Kazderová M, Tesar V, Zima T: Receptor for advanced glycation end products--soluble form and gene polymorphisms in chronic haemodialysis patients. *Nephrol Dial Transplant* 2007, 22(7):2020-2026.
294. Franke S, Müller A, Sommer M, Busch M, Kientsch-Engel R, Stein G: Serum levels of total homocysteine, homocysteine metabolites and of advanced glycation end-products (AGEs) in patients after renal transplantation. *Clin Nephrol* 2003, 59(2):88-97.
295. Moroz OV, Antson AA, Dodson EJ, Burrell HJ, Grist SJ, Lloyd RM, Maitland NJ, Dodson GG, Wilson KS, Lukanidin E *et al*: The structure of S100A12 in a hexameric form and its proposed role in receptor signalling. *Acta Crystallogr D Biol Crystallogr* 2002, 58(Pt 3):407-413.
296. Shishibori T, Oyama Y, Matsushita O, Yamashita K, Furuichi H, Okabe A, Maeta H, Hata Y, Kobayashi R: Three distinct anti-allergic drugs, amlexanox, cromolyn and tranilast, bind to S100A12 and S100A13 of the S100 protein family. *Biochem J* 1999, 338 (Pt 3):583-589.

297. Foell D, Kucharzik T, Kraft M, Vogl T, Sorg C, Domschke W, Roth J: Neutrophil derived human S100A12 (EN-RAGE) is strongly expressed during chronic active inflammatory bowel disease. *Gut* 2003, 52(6):847-853.
298. Hasegawa T, Kosaki A, Kimura T, Matsubara H, Mori Y, Okigaki M, Masaki H, Toyoda N, Inoue-Shibata M, Kimura Y *et al*: The regulation of EN-RAGE (S100A12) gene expression in human THP-1 macrophages. *Atherosclerosis* 2003, 171(2):211-218.
299. Foell D, Wittkowski H, Hammerschmidt I, Wulffraat N, Schmeling H, Frosch M, Horneff G, Kuis W, Sorg C, Roth J: Monitoring neutrophil activation in juvenile rheumatoid arthritis by S100A12 serum concentrations. *Arthritis Rheum* 2004, 50(4):1286-1295.
300. Foell D, Kane D, Bresnihan B, Vogl T, Nacken W, Sorg C, Fitzgerald O, Roth J: Expression of the pro-inflammatory protein S100A12 (EN-RAGE) in rheumatoid and psoriatic arthritis. *Rheumatology (Oxford)* 2003, 42(11):1383-1389.
301. Foell D, Seeliger S, Vogl T, Koch HG, Maschek H, Harms E, Sorg C, Roth J: Expression of S100A12 (EN-RAGE) in cystic fibrosis. *Thorax* 2003, 58(7):613-617.
302. Foell D, Ichida F, Vogl T, Yu X, Chen R, Miyawaki T, Sorg C, Roth J: S100A12 (EN-RAGE) in monitoring Kawasaki disease. *Lancet* 2003, 361(9365):1270-1272.
303. Komatsuda A, Ohtani H, Wakui H, Chyzh KA, Hatakeyama T, Iwamoto K, Maki N, Kimura T, Hitomi J, Sawada K: Increased serum levels of S100A12 in patients with MPO-ANCA-associated glomerulonephritis. *Clin Nephrol* 2006, 66(5):315-321.
304. Kosaki A, Hasegawa T, Kimura T, Iida K, Hitomi J, Matsubara H, Mori Y, Okigaki M, Toyoda N, Masaki H *et al*: Increased plasma S100A12 (EN-RAGE) levels in patients with type 2 diabetes. *J Clin Endocrinol Metab* 2004, 89(11):5423-5428.
305. Ross R: Atherosclerosis--an inflammatory disease. *N Engl J Med* 1999, 340(2):115-126.
306. Verma S, Devaraj S, Jialal I: Is C-reactive protein an innocent bystander or proatherogenic culprit? C-reactive protein promotes atherothrombosis. *Circulation* 2006, 113(17):2135-2150; discussion 2150.
307. Romão JE, Haiashi AR, Elias RM, Luders C, Ferraboli R, Castro MC, Abensur H: Positive acute-phase inflammatory markers in different stages of chronic kidney disease. *Am J Nephrol* 2006, 26(1):59-66.
308. Mahajan N, Bahl A, Dhawan V: C-reactive protein (CRP) up-regulates expression of receptor for advanced glycation end products (RAGE) and its inflammatory ligand EN-RAGE in THP-1 cells: inhibitory effects of atorvastatin. *Int J Cardiol* 2010, 142(3):273-278.
309. Hocheppied T, Berger FG, Baumann H, Libert C: Alpha(1)-acid glycoprotein: an acute phase protein with inflammatory and immunomodulating properties. *Cytokine Growth Factor Rev* 2003, 14(1):25-34.
310. Forbes JM, Thorpe SR, Thallas-Bonke V, Pete J, Thomas MC, Deemer ER, Bassal S, El-Osta A, Long DM, Panagiotopoulos S *et al*: Modulation of soluble receptor for advanced glycation end products by angiotensin-converting enzyme-1 inhibition in diabetic nephropathy. *J Am Soc Nephrol* 2005, 16(8):2363-2372.
311. Fialová L, Kalousová M, Soukupová J, Sulková S, Merta M, Jelínková E, Horejsí M, Srámek P, Malbohan I, Mikulíková L *et al*: Relationship of pregnancy-associated plasma protein-a to renal function and dialysis modalities. *Kidney Blood Press Res* 2004, 27(2):88-95.
312. Chung AW, Booth AD, Rose C, Thompson CR, Levin A, van Breemen C: Increased matrix metalloproteinase 2 activity in the human internal mammary artery is

- associated with ageing, hypertension, diabetes and kidney dysfunction. *J Vasc Res* 2008, 45(4):357-362.
313. Chou FP, Chu SC, Cheng MC, Yang SF, Cheung WN, Chiou HL, Hsieh YS: Effect of haemodialysis on the plasma level of type IV collagenases and their inhibitors. *Clin Biochem* 2002, 35(5):383-388.
 314. Peiskerová M, Kalousová M, Kratochvílová M, Dusilová-Sulková S, Uhrová J, Bandúr S, Malbohan IM, Zima T, Tesar V: Fibroblast growth factor 23 and matrix-metalloproteinases in patients with chronic kidney disease: are they associated with cardiovascular disease? *Kidney Blood Press Res* 2009, 32(4):276-283.
 315. Turck J, Pollock AS, Lee LK, Marti HP, Lovett DH: Matrix metalloproteinase 2 (gelatinase A) regulates glomerular mesangial cell proliferation and differentiation. *J Biol Chem* 1996, 271(25):15074-15083.
 316. Marti HP: [Role of matrix metalloproteinases in the progression of renal lesions]. *Presse Med* 2000, 29(14):811-817.
 317. Jerums G, Panagiotopoulos S, Tsalamandris C, Allen TJ, Gilbert RE, Comper WD: Why is proteinuria such an important risk factor for progression in clinical trials? *Kidney Int Suppl* 1997, 63:S87-92.
 318. Wang Y, Chen J, Chen L, Tay YC, Rangan GK, Harris DC: Induction of monocyte chemoattractant protein-1 in proximal tubule cells by urinary protein. *J Am Soc Nephrol* 1997, 8(10):1537-1545.
 319. Goumenos DS, Tsamandas AC, Oldroyd S, Sotsiou F, Tsakas S, Petropoulou C, Bonikos D, El Nahas AM, Vlachoianis JG: Transforming growth factor-beta(1) and myofibroblasts: a potential pathway towards renal scarring in human glomerular disease. *Nephron* 2001, 87(3):240-248.
 320. Cheng S, Lovett DH: Gelatinase A (MMP-2) is necessary and sufficient for renal tubular cell epithelial-mesenchymal transformation. *Am J Pathol* 2003, 162(6):1937-1949.
 321. Chang HR, Kuo WH, Hsieh YS, Yang SF, Lin CC, Lee ML, Lian JD, Chu SC: Circulating matrix metalloproteinase-2 is associated with cystatin C level, posttransplant duration, and diabetes mellitus in kidney transplant recipients. *Transl Res* 2008, 151(4):217-223.
 322. Büyükbabani N, Droz D: Distribution of the extracellular matrix components in human glomerular lesions. *J Pathol* 1994, 172(2):199-207.
 323. Fang Z, He F, Chen S, Sun X, Zhu Z, Zhang C: Albumin modulates the production of matrix metalloproteinases-2 and -9 in podocytes. *J Huazhong Univ Sci Technolog Med Sci* 2009, 29(6):710-714.
 324. Barrett AJ: Alpha 2-macroglobulin. *Methods Enzymol* 1981, 80 Pt C:737-754.
 325. Beaudoux JL, Burc L, Imbert-Bismut F, Giral P, Bernard M, Bruckert E, Chapman MJ: Serum plasma pregnancy-associated protein A: a potential marker of echogenic carotid atherosclerotic plaques in asymptomatic hyperlipidemic subjects at high cardiovascular risk. *Arterioscler Thromb Vasc Biol* 2003, 23(1):e7-10.
 326. Holland DC, Lam M: Predictors of hospitalization and death among pre-dialysis patients: a retrospective cohort study. *Nephrol Dial Transplant* 2000, 15(5):650-658.
 327. Davies M, Thomas GJ, Martin J, Lovett DH: The purification and characterization of a glomerular-basement-membrane-degrading neutral proteinase from rat mesangial cells. *Biochem J* 1988, 251(2):419-425.
 328. Baricos WH: Chronic renal disease: do metalloproteinase inhibitors have a demonstrable role in extracellular matrix accumulation? *Curr Opin Nephrol Hypertens* 1995, 4(4):365-368.

329. Imai K, Ohuchi E, Aoki T, Nomura H, Fujii Y, Sato H, Seiki M, Okada Y: Membrane-type matrix metalloproteinase 1 is a gelatinolytic enzyme and is secreted in a complex with tissue inhibitor of metalloproteinases 2. *Cancer Res* 1996, 56(12):2707-2710.
330. Papakonstantinou E, Roth M, Kokkas B, Papadopoulos C, Karakiulakis G: Losartan inhibits the angiotensin II-induced modifications on fibrinolysis and matrix deposition by primary human vascular smooth muscle cells. *J Cardiovasc Pharmacol* 2001, 38(5):715-728.
331. Koide H, Nakamura T, Ebihara I, Tomino Y: Increased mRNA expression of metalloproteinase-9 in peripheral blood monocytes from patients with immunoglobulin A nephropathy. *Am J Kidney Dis* 1996, 28(1):32-39.
332. Danilewicz M, Wagrowska-Danilewicz M: Differential glomerular immunoexpression of matrix metalloproteinases MMP-2 and MMP-9 in idiopathic IgA nephropathy and Schoenlein-Henoch nephritis. *Folia Histochem Cytobiol* 2010, 48(1):63-67.
333. Lods N, Ferrari P, Frey FJ, Kappeler A, Berthier C, Vogt B, Marti HP: Angiotensin-converting enzyme inhibition but not angiotensin II receptor blockade regulates matrix metalloproteinase activity in patients with glomerulonephritis. *J Am Soc Nephrol* 2003, 14(11):2861-2872.
334. McMillan JI, Riordan JW, Couser WG, Pollock AS, Lovett DH: Characterization of a glomerular epithelial cell metalloproteinase as matrix metalloproteinase-9 with enhanced expression in a model of membranous nephropathy. *J Clin Invest* 1996, 97(4):1094-1101.
335. Liu S, Li Y, Zhao H, Chen D, Huang Q, Wang S, Zou W, Zhang Y, Li X, Huang H: Increase in extracellular cross-linking by tissue transglutaminase and reduction in expression of MMP-9 contribute differentially to focal segmental glomerulosclerosis in rats. *Mol Cell Biochem* 2006, 284(1-2):9-17.
336. Robak E, Wierzbowska A, Chmiela M, Kulczycka L, Sysa-Jedrejowska A, Robak T: Circulating total and active metalloproteinase-9 and tissue inhibitor of metalloproteinases-1 in patients with systemic lupus erythomatosus. *Mediators Inflamm* 2006, 2006(1):17898.
337. Faber-Elmann A, Sthoeger Z, Tcherniack A, Dayan M, Mozes E: Activity of matrix metalloproteinase-9 is elevated in sera of patients with systemic lupus erythematosus. *Clin Exp Immunol* 2002, 127(2):393-398.
338. Makowski GS, Ramsby ML: Concentrations of circulating matrix metalloproteinase 9 inversely correlate with autoimmune antibodies to double stranded DNA: implications for monitoring disease activity in systemic lupus erythematosus. *Mol Pathol* 2003, 56(4):244-247.
339. Jiang Z, Sui T, Wang B: Relationships between MMP-2, MMP-9, TIMP-1 and TIMP-2 levels and their pathogenesis in patients with lupus nephritis. *Rheumatol Int* 2010, 30(9):1219-1226.
340. Cosin-Sales J, Christiansen M, Kaminski P, Oxvig C, Overgaard MT, Cole D, Holt DW, Kaski JC: Pregnancy-associated plasma protein A and its endogenous inhibitor, the proform of eosinophil major basic protein (proMBP), are related to complex stenosis morphology in patients with stable angina pectoris. *Circulation* 2004, 109(14):1724-1728.
341. de Leeuw K, Sanders JS, Stegeman C, Smit A, Kallenberg CG, Bijl M: Accelerated atherosclerosis in patients with Wegener's granulomatosis. *Ann Rheum Dis* 2005, 64(5):753-759.

342. Bjerkeli V, Halvorsen B, Damås JK, Nordøy I, Yndestad A, Aukrust P, Frøland SS: Expression of matrix metalloproteinases in patients with Wegener's granulomatosis. *Ann Rheum Dis* 2004, 63(12):1659-1663.
343. Xie Q, Zhou Y, Xu Z, Yang Y, Kuang D, You H, Ma S, Hao C, Gu Y, Lin S *et al*: The ratio of CRP to prealbumin levels predict mortality in patients with hospital-acquired acute kidney injury. *BMC Nephrol* 2011, 12:30.
344. Perez Valdivieso JR, Bes-Rastrollo M, Monedero P, de Irala J, Lavilla FJ: Impact of prealbumin levels on mortality in patients with acute kidney injury: an observational cohort study. *J Ren Nutr* 2008, 18(3):262-268.
345. Zoccali C, Mallamaci F, Tripepi G, Cutrupi S, Parlongo S, Malatino LS, Bonanno G, Rapisarda F, Fatuzzo P, Seminara G *et al*: Fibrinogen, mortality and incident cardiovascular complications in end-stage renal failure. *J Intern Med* 2003, 254(2):132-139.
346. Goicoechea M, de Vinuesa SG, Gómez-Campderá F, Aragoncillo I, Verdalles U, Mosse A, Luño J: Serum fibrinogen levels are an independent predictor of mortality in patients with chronic kidney disease (CKD) stages 3 and 4. *Kidney Int Suppl* 2008(111):S67-70.
347. Malyszko J, Malyszko JS, Pawlak D, Pawlak K, Buczko W, Mysliwiec M: Hemostasis, platelet function and serotonin in acute and chronic renal failure. *Thromb Res* 1996, 83(5):351-361.
348. Kalousová M, Zima T, Tesar V, Sulková S, Fialová L: Relationship between advanced glycoxidation end products, inflammatory markers/acute-phase reactants, and some autoantibodies in chronic haemodialysis patients. *Kidney Int Suppl* 2003(84):S62-64.
349. Kalousová M, Bartosová K, Zima T, Skibová J, Teplan V, Víklický O: Pregnancy-associated plasma protein a and soluble receptor for advanced glycation end products after kidney transplantation. *Kidney Blood Press Res* 2007, 30(1):31-37.
350. Sadik NA, Mohamed WA, Ahmed MI: The association of receptor of advanced glycated end products and inflammatory mediators contributes to endothelial dysfunction in a prospective study of acute kidney injury patients with sepsis. *Mol Cell Biochem* 2012, 359(1-2):73-81.
351. Zakiyanov O, Kalousová M, Zima T, Tesař V: Placental growth factor in patients with decreased renal function. *Ren Fail* 2011, 33(3):291-297.
352. Kim JK, Park S, Lee MJ, Song YR, Han SH, Kim SG, Kang SW, Choi KH, Kim HJ, Yoo TH: Plasma levels of soluble receptor for advanced glycation end products (sRAGE) and proinflammatory ligand for RAGE (EN-RAGE) are associated with carotid atherosclerosis in patients with peritoneal dialysis. *Atherosclerosis* 2012, 220(1):208-214.
353. Kalousová M, Kuběna AA, Benáková H, Dusilová-Sulková S, Tesař V, Zima T: EN-RAGE (extracellular newly identified receptor for advanced glycation end-products binding protein) and mortality of long-term haemodialysis patients: A prospective observational cohort study. *Clin Biochem* 2012, 45(7-8):556-560.
354. Osikov MV: Role of orosomucoid in the regulation of plasma proteolytic systems during experimental renal failure. *Bull Exp Biol Med* 2009, 148(1):20-22.
355. Wang H, Liao H, Ochani M, Justiniani M, Lin X, Yang L, Al-Abed Y, Metz C, Miller EJ, Tracey KJ *et al*: Cholinergic agonists inhibit HMGB-1 release and improve survival in experimental sepsis. *Nat Med* 2004, 10(11):1216-1221.
356. Wang H, Zhu S, Zhou R, Li W, Sama AE: Therapeutic potential of HMGB-1-targeting agents in sepsis. *Expert Rev Mol Med* 2008, 10:e32.

357. Uchino S, Kellum JA, Bellomo R, Doig GS, Morimatsu H, Morgera S, Schetz M, Tan I, Bouman C, Macedo E *et al*: Acute renal failure in critically ill patients: a multinational, multicenter study. *JAMA* 2005, 294(7):813-818.
358. Lauzurica R, Pastor C, Bayés B, Hernández JM, Romero R: Pretransplant pregnancy-associated plasma protein-a as a predictor of chronic allograft nephropathy and posttransplant cardiovascular events. *Transplantation* 2005, 80(10):1441-1446.
359. Schmidt AM, Hori O, Chen JX, Li JF, Crandall J, Zhang J, Cao R, Yan SD, Brett J, Stern D: Advanced glycation endproducts interacting with their endothelial receptor induce expression of vascular cell adhesion molecule-1 (VCAM-1) in cultured human endothelial cells and in mice. A potential mechanism for the accelerated vasculopathy of diabetes. *J Clin Invest* 1995, 96(3):1395-1403.
360. Yano K, Okada Y, Beldi G, Shih SC, Bodyak N, Okada H, Kang PM, Luscinskas W, Robson SC, Carmeliet P *et al*: Elevated levels of placental growth factor represent an adaptive host response in sepsis. *J Exp Med* 2008, 205(11):2623-2631.
361. Narvaez-Rivera RM, Rendon A, Salinas-Carmona MC, Rosas-Taraco AG: Soluble RAGE as a severity marker in community acquired pneumonia associated sepsis. *BMC Infect Dis* 2012, 12:15.
362. Bopp C, Hofer S, Weitz J, Bierhaus A, Nawroth PP, Martin E, Büchler MW, Weigand MA: sRAGE is elevated in septic patients and associated with patients outcome. *J Surg Res* 2008, 147(1):79-83.
363. Achouiti A, Föll D, Vogl T, van Till JW, Laterre PF, Dugernier T, Wittebole X, Boermeester MA, Roth J, van der Poll T *et al*: S100A12 and Soluble Receptor for Advanced Glycation End Products Levels During Human Severe Sepsis. *Shock* 2013, 40(3):188-194.
364. Mantell LL, Parrish WR, Ulloa L: Hmgb-1 as a therapeutic target for infectious and inflammatory disorders. *Shock* 2006, 25(1):4-11.
365. Ulloa L, Messmer D: High-mobility group box 1 (HMGB-1) protein: friend and foe. *Cytokine Growth Factor Rev* 2006, 17(3):189-201.
366. Sundén-Cullberg J, Norrby-Teglund A, Rouhiainen A, Rauvala H, Herman G, Tracey KJ, Lee ML, Andersson J, Tokics L, Treutiger CJ: Persistent elevation of high mobility group box-1 protein (HMGB-1) in patients with severe sepsis and septic shock. *Crit Care Med* 2005, 33(3):564-573.

8 PUBLICATIONS OF THE AUTHOR

8.1 LIST OF PUBLICATIONS THAT FORMED THE BASIS FOR THE THESIS

1. Zakiyanov O, Kalousová M, Zima T, Tesař V. Placental growth factor in patients with decreased renal function. *Ren Fail.* 2011;33(3):291-7. **IF: 0.824**
2. Zakiyanov O, Kalousová M, Kříha V, Zima T, Tesař V. Serum A100A12 (EN-RAGE) levels in patients with decreased renal function and subclinical chronic inflammatory disease. *Kidney Blood Press Res* 2011;34:457–464 **IF: 1.464**
3. Zakiyanov O, Kalousová M, Kratochvilová M. Kříha V, Zima T, Tesař V. Determinants of Circulating Matrix Metalloproteinase-2 and Pregnancy-Associated Plasma Protein-A in Patients with Chronic Kidney Disease. *Clin Lab* 2012; 58(5-6):471-480. **IF: 0.920**
4. Zakiyanov O, Kalousová M, Kratochvilová M. Kříha V, Zima T, Tesař V. Changes in levels of matrix metalloproteinase-2 and -9, pregnancy-associated plasma protein-A in patients with various nephropathies. *J Nephrol* 2013; 26 (3):502-509. **IF: 1.640**
5. Zakiyanov O, Kříha V, Vachek J, Zima T, Tesař V, Kalousová M. Placental growth factor, pregnancy associated plasma protein – A, soluble receptor for advanced glycation end products, extracellular newly identified receptor for receptor for advanced glycation end products binding protein and high mobility group box 1 levels in patients with acute kidney injury: a cross sectional study. *BMC Nephrol* 2013; 14 (1):245 **IF: 1.640**

8.2 LIST OF OTHER PUBLICATIONS

1. Kratochvilová M, Zakiyanov O, Kalousová M, Kříha V, Zima T, Tesař V. Associations of serum levels of advanced glycation end products with nutrition markers and anaemia in patients with chronic kidney disease. *Ren Fail.* 2011;33(2):131-7. **IF: 0.824**

2. Zakiyanov O., Mertová J., Šaková R., Polakovič V. Maligní hypertenze jako závažná komplikace koarktace aorty diagnostikovaná v pokročilém věku. Prakt. Léč. 2005, 85 (9):503-505
3. Hanuš T., Tesař V., Bednářová V., Zakiyanov O.: Nemoci močové soustavy (kapitola 2.3.9). In: Závěrečná zpráva veřejné zakázky MPSV ČR: Zpracování odborných lékařských podkladů pro funkční posuzování zdravotního stavu a pracovní schopnosti. Publikace pro posudkovou službu sociálního zabezpečení. Praha: MPSV, 2009. 196 s.
4. Vachek J, Zakiyanov O., Tesař V. Farmakoterapie diabetes mellitus 2. typu u pacientů s chronickým onemocněním ledvin. Kazuistiky v diabetologii 9, č. 5:10-13, 2011
5. Vachek J, Zakiyanov O., Tesař V. Chronické onemocnění ledvin. Interní Medicína pro Praxi. 2012 14(3):107-110.
6. Vachek J, Zakiyanov O., Frausová D, Tesař V. Výživa při chronickém onemocnění ledvin. Aktuality v nefrologii. 2013 19 (2): 59-61.
7. Vachek J., Tesař V., Zakiyanov O., Maxová K. Farmakoterapie v těhotenství a při kojení. Praha, Maxdorf, 2013, ISBN 978-80-7345-333-6.

9 APPENDIX

Appendix 1: Zakiyanov O, Kalousová M, Zima T, Tesař V. Placental growth factor in patients with decreased renal function. *Ren Fail.* 2011;33(3):291-7.

Appendix 2: Zakiyanov O, Kalousová M, Kříha V, Zima T, Tesař V. Serum A100A12 (EN-RAGE) levels in patients with decreased renal function and subclinical chronic inflammatory disease. *Kidney Blood Press Res* 2011;34:457–464.

Appendix 3: Zakiyanov O, Kalousová M, Kratochvilová M. Kříha V, Zima T, Tesař V. Determinants of Circulating Matrix Metalloproteinase-2 and Pregnancy-Associated Plasma Protein-A in Patients with Chronic Kidney Disease. *Clin Lab* 2012; 58(5-6):471-480.

Appendix 4: Zakiyanov O, Kalousová M, Kratochvilová M. Kříha V, Zima T, Tesař V. Changes in levels of matrix metalloproteinase-2 and -9, pregnancy-associated plasma protein–A in patients with various nephropathies. *J Nephrol* 2013; 26 (3):502-509.

Appendix 5: Zakiyanov O, Kříha V, Vachek J, Zima T, Tesař V, Kalousová M. Placental growth factor, pregnancy associated plasma protein – A, soluble receptor for advanced glycation end products, extracellular newly identified receptor for receptor for advanced glycation end products binding protein and high mobility group box 1 levels in patients with acute kidney injury: a cross sectional study. *BMC Nephrol* 2013; 14 (1):245