

Roman Metal Vessels in the Milieu of Germanic Elites in the Middle Danube Region

Jan Jílek

ABSTRACT

This text summarises the current state of research into Roman metal vessels and confronts it with finds from the Middle Danube region. The occurrence of such metal vessels, connected usually with the elites, will be placed against relevant historical context, especially within the Roman Period.

KEYWORDS

Roman Period; metal vessels; Germanic elites; Middle Danube region.

INTRODUCTION

The aim of this paper is to provide information on Roman metal vessels in rich graves contexts in Middle Danube region and to call attention to relationship between this category of artefacts and burial rites.

The problem of metal vessels stands out as one of more popular topics of the proto-historic research. The reason for such popularity is the fact that this type of artefacts continues to generate new questions. Starting in the 1970s, the traditional research topics, such as dating, production centres, distribution or stylistic analysis became supplemented with another frequently studied phenomenon – the significance of metal vessels among the barbarian elites. This topic has been most recently treated in a comprehensive way by J. Schuster (2010) and M. Becker (2010), who also summed up previous bibliography. E. Hrnčiarik (2013) recently paid attention to presumed function of metal vessels in the Middle Danubian Barbaricum.

ON THE SIGNIFICANCE OF METAL VESSELS IN ELITE GRAVES DURING THE EARLY ROMAN PERIOD

Metal vessels, prevalently made of bronze/brass, began to occur in the Middle Danube region in larger quantities from the B1b phase (25/30–50 AD; KOLNÍK 1977, 154), above all from the third decade of the 1st century AD. We know them not only from Southwestern Slovakia and from the Morava River basin, but also from Lower Austria north of the Danube (JÍLEK 2012, with further bibliography). It was probably in this area where the retinues of Maroboduus and Catualda, including their families, may have settled down after their flight from Bohemia (DROBERJAR 2009, 100; TEJRAL 2009, 182). This fact is, according to T. Kolník (1977, 161), indicated by some metal vessels (saucepan of the type E 131, cauldron of the type E 8, basin of the type E 92, ladle and strainer sets of the type E 159) corresponding to the range of Bohemian finds. This population transfer along with other political circumstances caused the emergence of the so-called Kingdom of Vannius (on this topic most recently KREKOVÍČ 2009, 182–183). The



metal vessels, which have been connected with this cultural and social formation, are found mainly in cremation graves.

At this point it is necessary to mention two finds of riveted metal cauldrons of the type E 8 from Mannersdorf an der March (a grave excavated in 1988; LAUERMANN 1994) and Kostolná pri Dunaji, Grave 35 (Fig. 1; KOLNÍK 1980), which were used as cinerary urns. The origins of the practice of using such vessels in burial rites have been sought in the territory west of Rhine, in the Celtic cultural sphere where we meet them in richly furnished graves of Late La Tène/Early Roman periods (PESCHEL 1995, 77-79; VOSS 2006, 25; JÍLEK 2012, 24, note 33). The custom of using cauldrons as urns was detected in various regions of Germania Magna during the stages A, B1 and B2 it is, however, dominant among the Elbe tribes where such burials are often richly furnished. In the context of the burial ground of Hagenow, H. U. Voss (2006, 35) regarded these graves as those of barbarian elite. This tradition continues in the Roman Period thanks to the occurrence of simpler variants of cauldrons. It is mainly evidenced by the Westland cauldrons, which are derived from the Gallic (Celtic) production procedures. We can name examples in graves of the barbarian elite from the end of the 2nd century (the royal tomb of Mušov: KÜNZL - KÜNZL 2002, 364) and the mid 3rd century (the princely grave of Gommern: KÜNZL 2010, 171; BECKER 2010).

Besides the above-mentioned cauldrons and other 'old-fashioned pieces', the spectrum of finds which are associated with the heyday of the Quadic and Marcomannic power on the Middle Danube includes also other types such as the saucepans of the type E 137, balsamaria of the type Ra 84. Their production began already in the Late Augustan Period, but continued until as late as the mid-50s AD, and in the case of the E 138 type saucepans even until the 2nd half of the 1st century AD. At the time of the Kingdom of Vannius we can identify a distinct share of Roman products in local material (HEČKOVÁ 1982, 12, 41, Tab. VI). This phenomenon has traditionally been associated with control of trading activities along the Amber Road (PELIKÁN 1977, 5; HEČKOVÁ 1982, 42; PITTS 1989, 48; TAUSEND 2009, 190-196; TEJRAL 2009, 193). An increase in number of Roman products is visible also in the territory of the Przeworsk culture, through which this communication route passed (GRALAK 2012, 93). This fact can probably be connected with the upswing of the Kingdom of Vannius and his successors who may have hypothetically taken part in organisation of trade and redistribution activities. The whole range of trading commodities which the barbarians were able to offer was already summarised by O. Brogan (1936, 219-221). An important role, as already mentioned above, was undoubtedly played by the import of amber which is mainly mentioned in written sources (generally on amber in the Roman Period see DIVAC 2013, 102, 105-106; NOWAKOWSKI 2012, 97-98). In archaeological material from the Morava River basin, the amber finds are rare, which according to the preliminary hypothesis of M. Čižmář (1998, 39-41) might be explained by the intermediary role of the studied area in amber trade as well as by the prevailing cremation rite. From territory of Poland we know several Roman Iron Age sites with evidence of amber working (WIELOWIEJSKI 1981, 373-374; SKOWRON 2015, 62-63, Ryc. 9), which indicates the importance of the 'Gold of the North' for the communities of that time. The knowledge of amber trade on the territory of Pannonia was enhanced recently by the results of Hungarian research. The culmination of trade activities has been postulated within the interval from 70 to 166 AD. From the territory of Roman provinces, we know both pieces of roughly worked raw material and amber ornaments produced in the surroundings of Aquileia and in the Pontic region (NAGY 1998, 151, 154-155).

The amount of data summarised above indicates the significance of amber in the barbarian-Roman relations and can thus be used as one of the explanations of the above-mentioned presence of Roman products in the power centres. However, also alternative explanations of

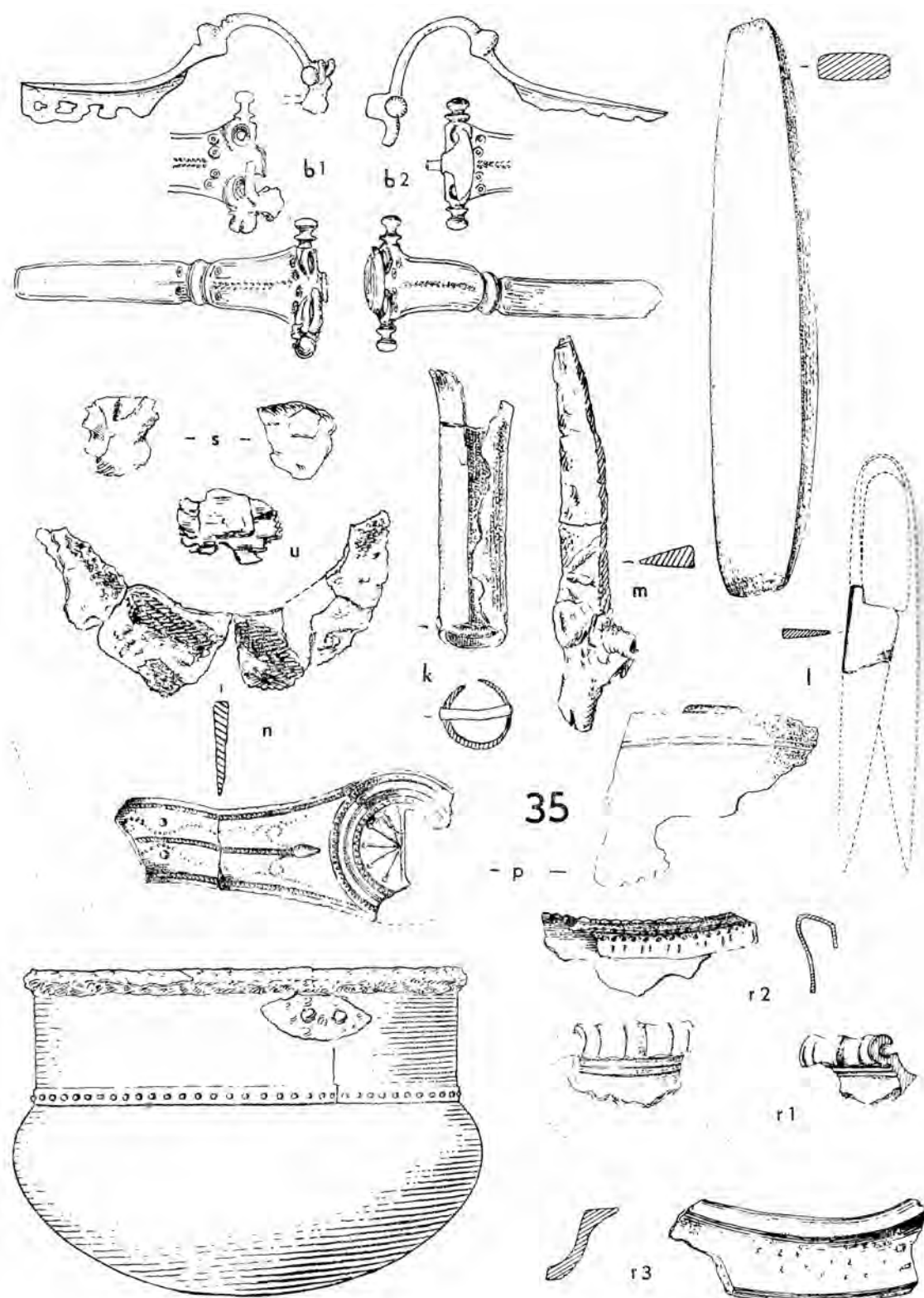

Fig. 1: Kostolná pri Dunaji, Grave 35. Selection of finds (after KOLNÍK 1980).



the accumulation of Roman import in the Middle Danube region have been sought recently. E. Hrnčiarik (2013, 227, 233) suggested, for example, the barbarian food supplies of provincial markets including the sparse military garrisons of for the 1st century AD. It is, however, necessary to mention that for the 1st century we are not sufficiently informed about the character of Quadic agriculture (HAJNALOVÁ – VARSÍK 2010, 216) and such considerations must therefore be regarded with caution. Hrnčiarik's hypothesis must be augmented by the significance of the opposite relationship, namely the Roman food support to barbarian client rulers in order to help them avoid unrests on their territories (BRAUND 1989, 19). Thanks to the Roman support, the barbarian elites were able to guarantee peace in their own territory, which may be one of their main 'export articles' of crucial importance to the Romans.

It is also important to mention the theories, according to which the concentration of Roman goods can be interpreted by the clientship between Vannius and the Roman administration, which may have produced advantages in the form of gifts, bribes and soldiers' pay (HEČKOVÁ 1982, 42) that the ruler could have used to strengthen his position (in general BRAUND 1989, 17–18).

The range of finds from the subsequent phase of the Roman Period builds fluently on the tendencies of the above-mentioned previous development. In the phase B1c (50–100 AD) after J. Tejral (1986, 105), the variety of Roman metal vessels broadened (situla-shaped buckets of the type E 25/26, buckets of the type E 39–40, basins of the type E 99–100, bowls with a horizontal handle of the type E 154–155, saucepans of the types E 140/142, 139/142, jugs of the types E 125, Ra 71, jug of the type E 122, ladles and strainers of the types E 160, E 162). Representative assemblages are known mainly from cremation graves in the burial grounds of Kostolná pri Dunaji, Sládkovičovo and Abrahám (KOLNÍK 1980). In these cemeteries, metal vessels were found in 106 graves out of the total of 393 burials dated to the 1st and the 2nd century¹ and they slightly prevailed in male graves (KREKovič 2008, Tab. 1). This information fits well into over-regional comparisons, as is confirmed by the observations of J. Kunow (1983, 108–109, Abb. 22) who found out that Roman vessels imported to the territory of the Elbe Germans are more frequent in male graves. The proportions are, however, not stable as far as regards the burials with weapons in the above-mentioned burial grounds. In Kostolná pri Dunaji, the majority of imported vessels were found in warriors' graves. In Abrahám, on the other hand, it was the very opposite. This fact might indicate different characteristics of both these burial grounds. It is possible that Kostolná may have represented a burial place for retinue members. We must, nevertheless, keep in mind that the burial grounds were not necessarily explored in their entirety (KREKovič 2006, 132–133; 2007, 91–93, 96). These findings should be supplemented with observations of H. Steuer (1992, 238) who called attention to joint occurrence of Roman vessels and products in general with drinking vessels, drinking horns, weapons (especially swords) and spurs. Accumulations of these graves, usually associated with retinue members, may indicate power centres, in which redistribution of valuables took place and which were probably connected with trade routes (KREKovič 2011, 83). Another relevant explanation, which was elaborated by H. U. Voss (2008, 267) for the wealthy burial ground in Hagenow, Mecklenburg, might be the engagement of the retinue members in Roman service. Good support to both of the above hypotheses is offered by find contexts (Stevns on Seeland, Lundeborg-Gudme) from Northern Europe, above all from what is now Denmark. Their dating, however, is not earlier than the Late/Final Roman Period and the Migration Period (STEUER 1994, 31–33).

1 In the text by E. Krekovič (2008, 113, Tab. 1) all the cremation graves in the cemetery are discussed as a whole without any detailed chronological specification. The development during the 1st and the 2nd century is thus not distinguished.



The accumulation of Roman products culminated in the last quarter of the 1st century and in the first half of the 2nd century (phase B1c and the early B2a; HRNČIARIK 2013, 217, Tab. 16). The origin of this situation must be sought in escalation of the above-mentioned phenomena a good argument for which may be the involvement of military retinues commanded by Italicus and Sido in the civil war, which broke out after the fall of the Julio-Claudian dynasty. In the Battle of Cremona (69 AD) these auxiliary forces fought on the side of the future Emperor Vespasian (KOLNÍK 1977, 167–168). These events may be reflected in the accumulation of Roman goods in richly furnished inhumation graves from Zohor, Vysoká pri Morave (Fig. 2, Pl. 6/1; ONDROUCH 1957) and Neuruppersdorf (Fig. 3; comprehensively KREKOVIČ 1992; TEJRAL 2001, 217, 219, 231). The most important among these sites is Zohor² where the inventory from six princely graves was recovered (comprehensively KREKOVIČ 1992; most recently ELSČEK 2013). The last grave was discovered in 2010. Some of these burials are characterised by the occurrence of bowls with horizontal handle of the type E 154–155 and jugs of the type Ra 71 (or in the case of Grave 6/2010 jug of the type E 125). Such sets of jugs and solid handle bowls of various types were used for hand washing during feasts and for hygiene in general (NUBER 1972, 117–120, 125; NENOVA-MERDJANOVA 2002, 202; 2011, 115–116, Fig. 1). Their placement in graves can be observed already in the Hellenistic Period, and this custom remained popular also in some Roman provinces (cf. in detail NUBER 1972). It is also known from burials of barbarian leaders where it counts among the interesting phenomena associated with elite graves in the territory northeast and east of the Roman frontier. In order to interpret this phenomenon properly it is necessary to take into account the work of H. Steuer (2006, 14–15, 19–20) who emphasized the importance of drinking tableware and horns mainly in funeral rites. The purpose of these rites in honour of the deceased may have been, for example, the legitimisation of a new ruler or – in a less direct way – communication between elite members. It is highly probable that the above-mentioned sets of vessels may also have been used during funerary feasts. The presence of bronze jugs of the types E 124–125 and bowls with a solid handle of the type E 154–155 in richly furnished barbarian inhumation and cremation graves can already be detected in the first third of the 1st century. From the territory of the Germanic Barbaricum we can name examples from Prague-Bubeneč (NOVOTNÝ 1955; DROBERJAR 2014a, 414); Zliv (SCHULZ 1885); Dobřichov-Pičhora, graves II, IV (DROBERJAR 1999); Hagenow, grave 1841/42 (VOSS 2006, 25, 44, Abb. 5). The custom of placing these sets of vessels in graves was also practised in the eastern parts of the world which was not permanently occupied by the Romans. From the Crimean site of Ust-Alma (Tomb 620) comes an oinochoe of the type E 125 and a bowl with a solid handle. The assemblage is dated between the middle and the 3rd quarter of the 1st century (LOBODA – PUZDROVSKIJ – ZAJCEV 2002, 337–338, Abb. 21:8–9). From the first half of the 1st century dates the Grave 9 from Cemdolina in Kuban whence comes a set of an E 124 jug and an E 154 solid handled bowl (SIMONENKO – MARČENKO – LIMBERIS 2008, 283, 288, 345, Taf. 60:5, 61:2). Apart from the graves containing complete vessel sets, there are others containing individual jugs or solid handled bowls. In these cases it is possible that either the solitary vessels represent individual components of original sets which got taken apart within the process of redistribution, or we can interpret this situation as evidence of the *pars pro toto* ritual.

2 In Zohor we find not only richly furnished inhumation and cremation graves but also an extensive settlement with evidence of pit houses and production activities of various kinds (ELSCHEK 2002, 247; 2013, 93–95).

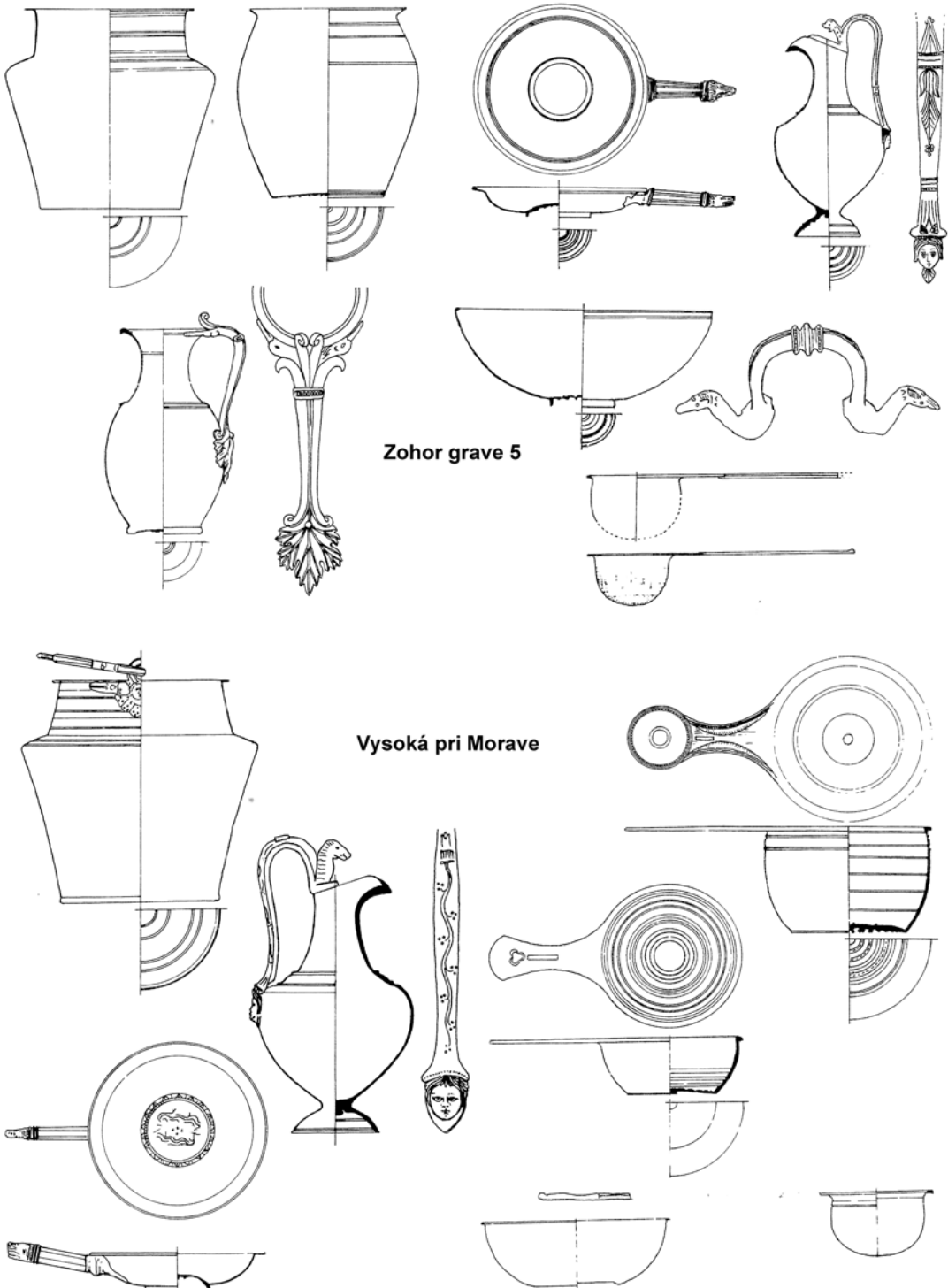

Fig. 2: Zohor, Grave 5 (top) and the grave from Vysoká pri Morave (bottom) (after KRASKOVSKÁ 1978).

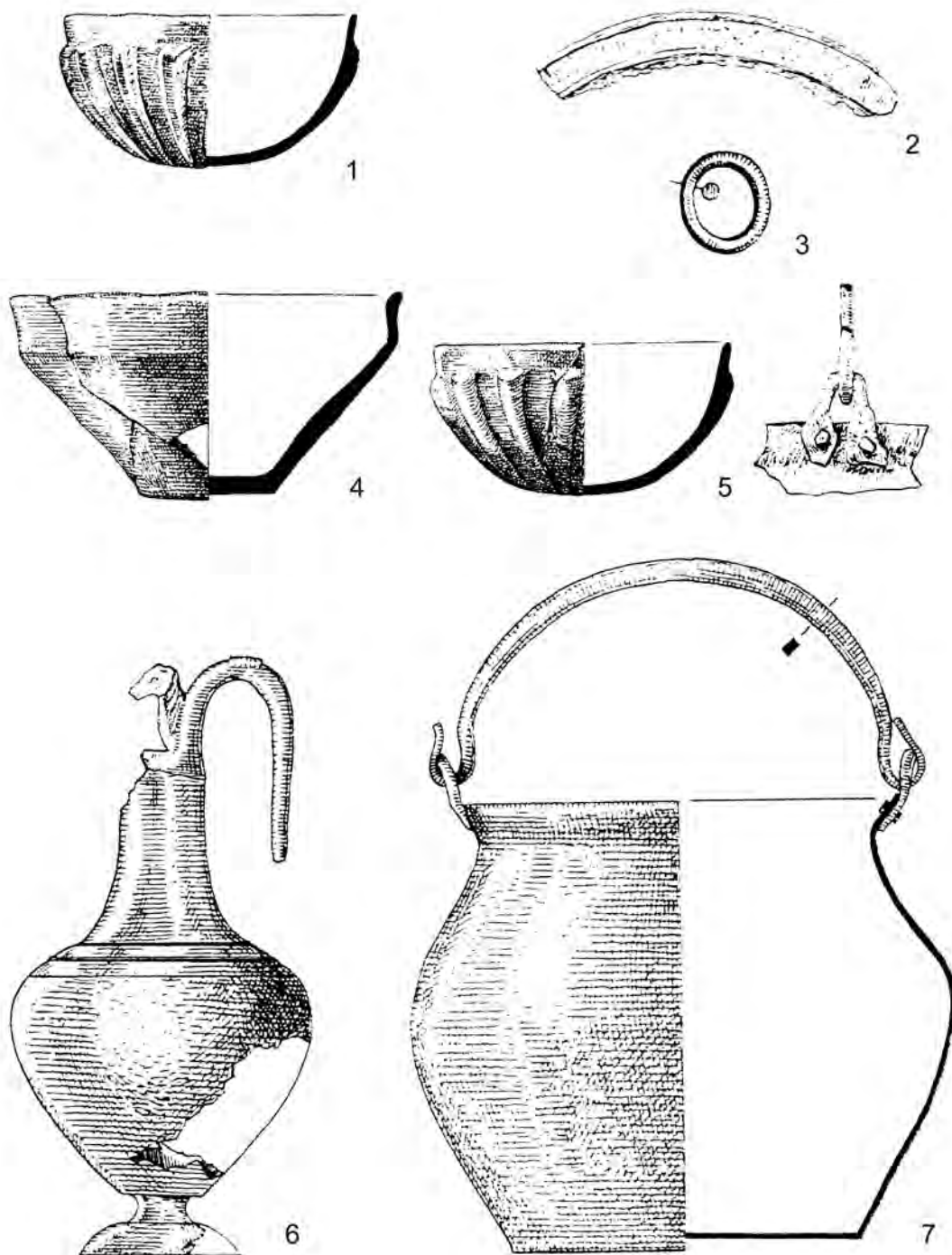

Fig. 3: Neuruppersdorf, richly furnished grave (after TEJRAL 2001).



The above-described cases make it clear that the habit of depositing the vessel set among grave goods was characteristic not only of Germanic population as early as the beginning of the 1st century. The occurrence of jugs and bowls with horizontal handle in richly furnished graves in Southwest Slovakia can thus testify to maintenance of funeral rites which were practised in Bohemia already at the time of Maroboduus. An important role may, however, also have been played by burial customs of the southern provincial milieu. Combinations of a fixed handle bowl and a jug are evidenced from the end of the 1st century to the 3rd century in Pannonia where they occur in richly furnished graves of provincial elite together with folding chairs and sometimes also with bath kits. These components of funerary equipment thus probably indicate that the local upper class had adopted the Roman lifestyle (comprehensively MRÁV 2013, 117–129). J. Tejral (2001, 229) rightly supposed that the Germanic elite inhabiting the territory north of Danube in the last quarter of the 1st century and the 1st half of the 2nd century tried to imitate some of the customs of provincial leaders. However, he emphasized the selective nature of this behaviour. The point is that not all the elements of funerary equipment which are known from the Roman provinces became widespread in barbarian environment. This phenomenon can be explained both by tradition of funerary customs and by specific demands of the big men who were buried in Zohor, Vysoká pri Morave and Neuruppersdorf. Among typical attributes of princely burials, not only those from the end of the 1st century, are silver goblets. These were put into graves either in pairs or as single pieces. They probably reflect the efforts to imitate Roman dining in specific conditions, typical of the barbarian territory (KÜNZL 1988, 50) where, for example, pairs of drinking horns are attested already in the late pre-Roman Period (SCHUSTER 2010, 275–276, note 1570). The occurrence of pairs of vessels might reflect older traditions. Therefore, they cannot be considered Roman drinking sets in the true (Roman) sense of the word, as it was recently supposed by E. Hrnčiarik (2013, 29) for the territory of Slovakia. Silver goblets surely represent diplomatic gifts intended for local rulers (most recently IBRAGIMOW – SCHÖNFELDER 2014, 114). They probably had symbolic function and may have served as objects representing the elite (Germ. *Rangsymbole*). Noble families did not hesitate to deposit them with the deceased in the grave after funerary feast (STEUER 2006, 14–15, 19–20). At this place it is also important to underline their significance as a part of family treasures, which may have been composed of diplomatic gifts and were placed in graves rather as prestige symbols (on this topic in general BRATHER 2005, 148–149, 169). Among good examples from Slovakia counts the Grave 5 from Zohor (KRASKOVSKÁ 1959, Obr. 59–61), which contained two silver kantharoid goblets with high-swung handles extending above the rim (Pl. 6/1). Interestingly enough, the Early Roman Period graves do not contain any other components of Roman silver sets, for example plates or trays (KÜNZL 1988, 35). The assemblages from the territory of Empire, which are mainly known from hoards and assemblages from the towns below Mt. Vesuvius, are more abundant and contain vessels which were integral parts of drinking sets, such as simpula, jugs or small strainers (most recently GUZZO 2006). In the Middle Danube region, however, such vessels appear rather sporadically, such as e.g. the simpulum from Schwechat (KÜNZL 1997, 147–149, Abb. 9, 10). It seems therefore that the picture which we observe in Germania Magna is again only an adaptation to the Roman milieu. This fact means that the pairs of silver goblets from Grave 5 in Zohor and from other sites in the Barbaricum (listed in KÜNZL 1988; SCHUSTER 2010; IBRAGIMOW – SCHÖNFELDER 2014) are not necessarily direct evidence for adoption of Roman drinking customs, even though they were indeed used for drinking.

Near the richly furnished burials Zohor grave 5 and 6/2010, a hoard of bronze vessels fragments was unearthed, some of them showing traces of melting (ELSCHEK 2002, 245–260, Abb. 3, 4:1–2, 4). This find indicates a specific treatment of metal vessels, somewhat different



from that described above. The fragments of vessels, some of them identical to pieces found in the inhumation graves, represent a reserve of raw material which was intended for further processing (ELSCHEK 2002, 245, 248; HRNČIARIK 2013, 224). The melted fragments might hypothetically come from vessels which were deposited in funeral pyres. The funerary equipment of cremation graves, which are also evidenced at the site (ELSCHEK 2009, 245), thus contained only a selection from burnt and melted grave goods (*a pars pro toto*). But how to interpret this behaviour? Important is the regional and chronological context. The hoard from Zohor is dated to the last third of the 1st century or to the 1st half of the 2nd century, that is to a period in which the inflow of metal vessels most probably culminated. These tendencies have usually been associated with the floruit of the Zohor power centre. It can thus be supposed that the needs and demands for metal vessels of the local population were fully saturated, so that purely practical reasons emerged, induced by easy access to vessels which were secondarily used as a source of metal. They lost their 'representative function' after funeral ceremonies and were simply ready for further use. Secondary processing of a whole range of Roman metal products is attested in the territory of Central Germany (Thuringia and southern Saxony-Anhalt) in the Late Roman Period. In this region, bronze from Roman vessels has often been used, as it is mainly evidenced by settlement finds and contexts (BECKER 2003, 287).

SPECIFIC FEATURES OF THE MIDDLE ROMAN PERIOD

The text above has briefly outlined the development in the Middle Danube region until the mid-2nd century. The subsequent phase, which is sometimes termed Middle Roman Period (the phases B2b, B2/C1 and C1), saw gradual changes of material culture of Germanic communities. These changes also concern the range of imported metal vessels. After the mid-2nd century, several types of fluted Roman vessels became more and more popular, including the bowls of the type Eggers 77 and buckets Eggers 44-49. The peak of occurrence of this group of artefacts in the Barbaricum falls into the time of the Marcomannic Wars through the first third of the 3rd century. Afterwards, this category of finds gradually disappears from funerary assemblages. From Southwest Slovakia we can name examples from a supposed grave from Dvory nad Žitavou (RUTTKAY 2004, 155, 156, Obr. 120:4; HRNČIARIK 2013, Tab. XVII:1530), finds from disturbed graves in Abrahám (KOLNÍK 1980, 80, Tab. LXVII:5), grave 3 (2/61) from Gbelce-Tehelňa, (BELJAK - KOLNÍK 2006, 85-87, Obr. 10) and grave 117 from Očkov in the Váh valley (KOLNÍK 2004, Abb. 9: P1, P2). Slovak finds are not isolated in the studied area - similar assemblages are found both in Moravia and in Lower Austria north of the Danube (JÍLEK 2012). J. Tejral (2006, 158) rightly called attention to changes in the manner of elite representation, under way in this period. A series of rich graves spread across the vast territory of the Barbaricum feature a canonical composition of grave goods well exemplified by the grave from Dvory nad Žitavou. These grave assemblages include fluted buckets, two glass goblets, ladle and strainer sets, and other Roman and barbarian luxury items, often of north-eastern origin. J. Tejral, the supreme authority of Central European research into the Roman Period, saw in this spread of a uniform burial rite a sign of an ideological interconnection of the Middle Danube region with the barbarian Northeast and North. He explained the inflow of Roman products by a favourable social situation after the peace of Commodus, when the Roman administration supported the barbarian leaders loyal to Rome. Of great importance was, however, also the inter-barbarian distribution of both Roman articles and objects of north-eastern origin (TEJRAL 2006, 155, 157-158, 166).

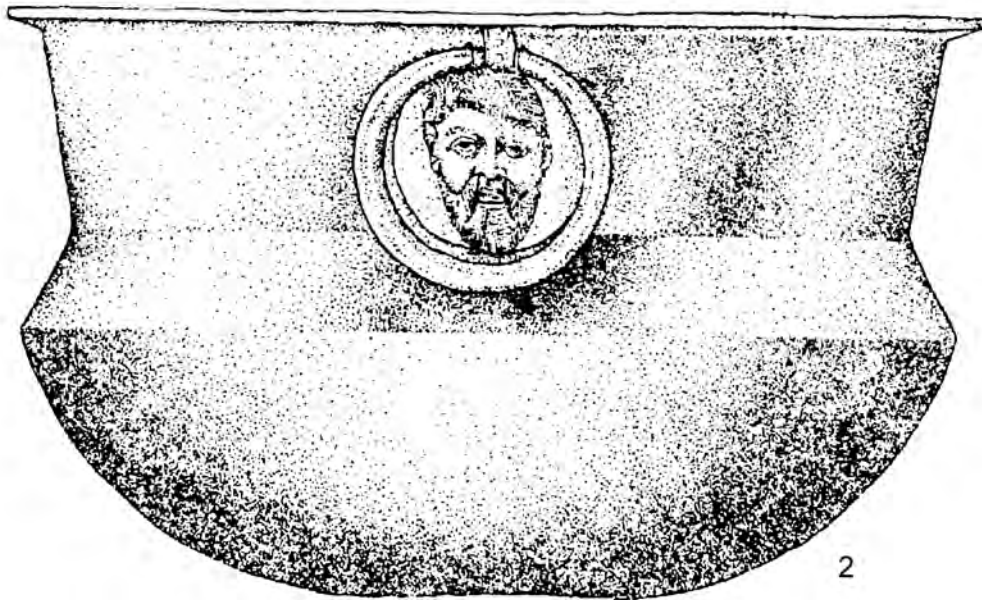
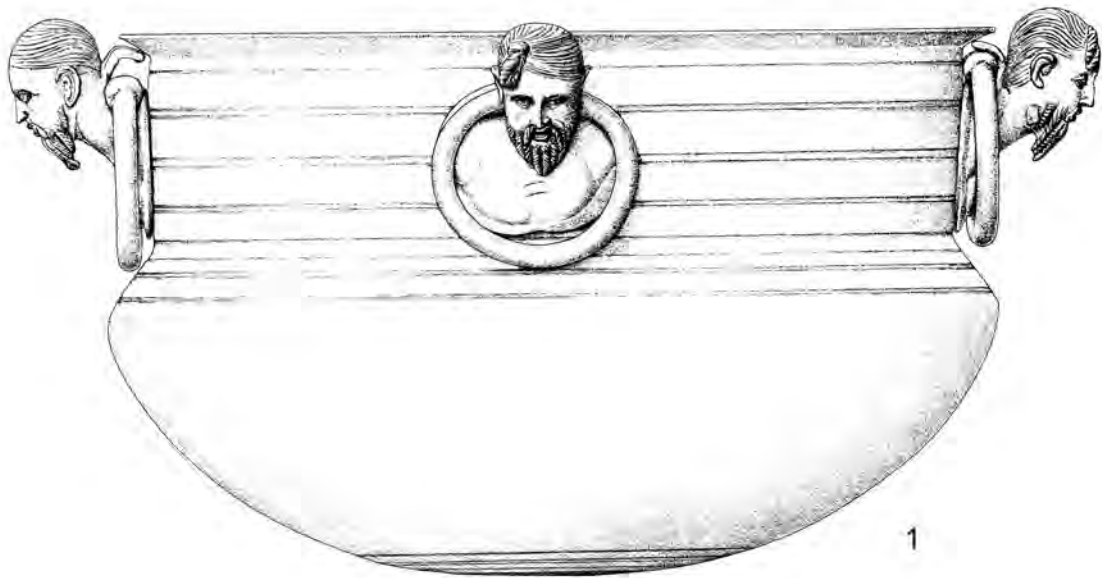

Fig. 4:1. Royal tomb of Mušov. Bronze cauldron (after PEŠKA - TEJRAL 2002); 2. Czarnówko - Grave 430. Bronze cauldron (after MAĆZYŃSKA - RUDNICKA 2004).

Given the range of finds, two funerary assemblages from the European Barbaricum stand out: the princely grave from Mušov (PEŠKA - TEJRAL 2002) and Czarnówko, grave 430 (MAĆZYŃSKA - RUDNICKA 2004), which contained precious Westland cauldrons with handle attachments and fittings decorated with the motifs of busts/heads of Germans (Fig. 4). Both of these vessels were certainly made for Germanic leaders and meet their taste and needs for self-identification and presentation. This type of relationships between Mediterranean centres and barbarian peripheral regions is documented also from other regions by K. R. Krierer (2002, 381, note 118).



The cauldron from Mušov may have also been a hypothetical gift for a Germanic king for his loyalty towards the Empire after the end of the Marcomannic Wars (KRIERER 2002, 381–382). Interesting in this regard is a concentration of bronze appliqués and statuettes of Germans in the surroundings of Brigetio in Pannonia (KRIERER 2002, 372–373; BARTUS 2011, 19–21, Fig. 2–3), which may have acted as a mediator of iconographic stimuli and maybe also as a production place of some of them. This assumption, however, cannot yet be confirmed in more detail by archaeological evidence.

Silver vessels also occurred in the Middle Roman Period. Among them there are rare fragments of Roman and barbarian goblets with skyphoid handles. The royal tomb of Mušov contained parts of a goblet which, according to stylistic analysis, falls within the Augustan Period. It certainly belonged to a family treasure, whose origin can be hypothetically sought in the time of King Maroboduus or of the successors of Vannius (BOUZEK 1994, 174; 2000). In a similar way we can also interpret the fragments of a silver goblet of barbarian origin from the Czarnówko grave which is, however, much more recent than the Mušov piece. The occurrence of only fragments (individual parts) of silver vessels is somewhat intriguing. Such parts can be interpreted as remnants of a princely treasure, from which the retinue members were rewarded. Fragmented vessels made of precious metals are attested, for example, in a later treasure from Młoteczno/Hammersdorf (BOTT 1976–1977, 147–153; WIELOWIEJSKI 1989, 200–201) or from the famous hoard of Pietroasa, which is dated to the first half of the 5th century (HARHOIU 1977, Pl. I; STEUER 1982, 95). Silver vessels may thus have served in particular cases as a source of precious metal. Parts of goblets with skyphoid handles from Mušov and Czarnówko can also indicate the continuity of the Early Roman Period tradition of depositing pairs of vessels. J. Schuster (2010, 280) offered an alternative explanation of their fragmentary state of preservation – according to him it is well possible that they give evidence of a behaviour in the sense of *pars pro toto*. Small fragments of silver vessels including pieces of a goblet with skyphoid handles were recently recovered from Feature 15/2008 in Zohor which probably had a sepulchral function. The context is dated to the timespan of the third quarter of the 2nd century till the beginning of the 3rd century. However, the vessel fragments are older, probably from the early 1st century (ELSCHEK – RAJTÁR – VARSÍK 2011, 137, 146, Obr. 7).

From the late 2nd century we also can follow up the occurrence of silver vessels, which were parts of dining sets, i.e. a change in the typological spectrum of the imported vessels. This phenomenon is again well documented by the royal tomb of Mušov (KÜNZL 2002, 351, 352) and by the richly furnished Grave II from Wulzeshofen, Lower Austria (BENINGER 1932, 218, Abb. 9).

MAIN CHARACTERISTICS OF THE LATE AND FINAL PHASES OF ROMAN PERIOD

Funeral rituals have gradually changed after the Marcomannic Wars. A typical trait of this process is the gradual impoverishment of burials. This phenomenon is mainly attested from cremation graves. T. Kolník (1961, 244; 1975, 356) regarded these changes as evidence of rationalisation of burial rites. Germanic communities thus focused on the ceremony itself rather than on grave goods. From this trend deviates the burial III from Krakovany-Stráže (Pl. 6/2), where a Hemmoor bucket of the Eggers' type 58 was used as the cinerary urn (ONDROUCH 1957, 168–169). It is a late display of ancient Elbe-Germanic traditions, whose roots lay in the Lower Elbe region as early as the late pre-Roman Period (JÍLEK 2012, 20).

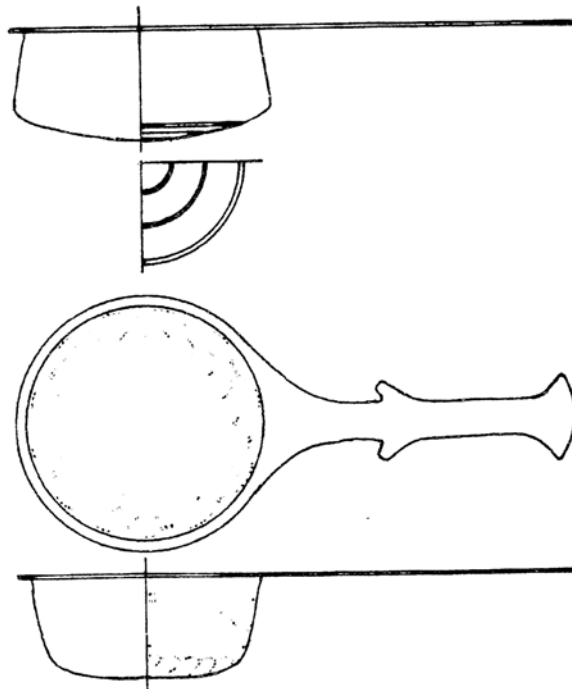
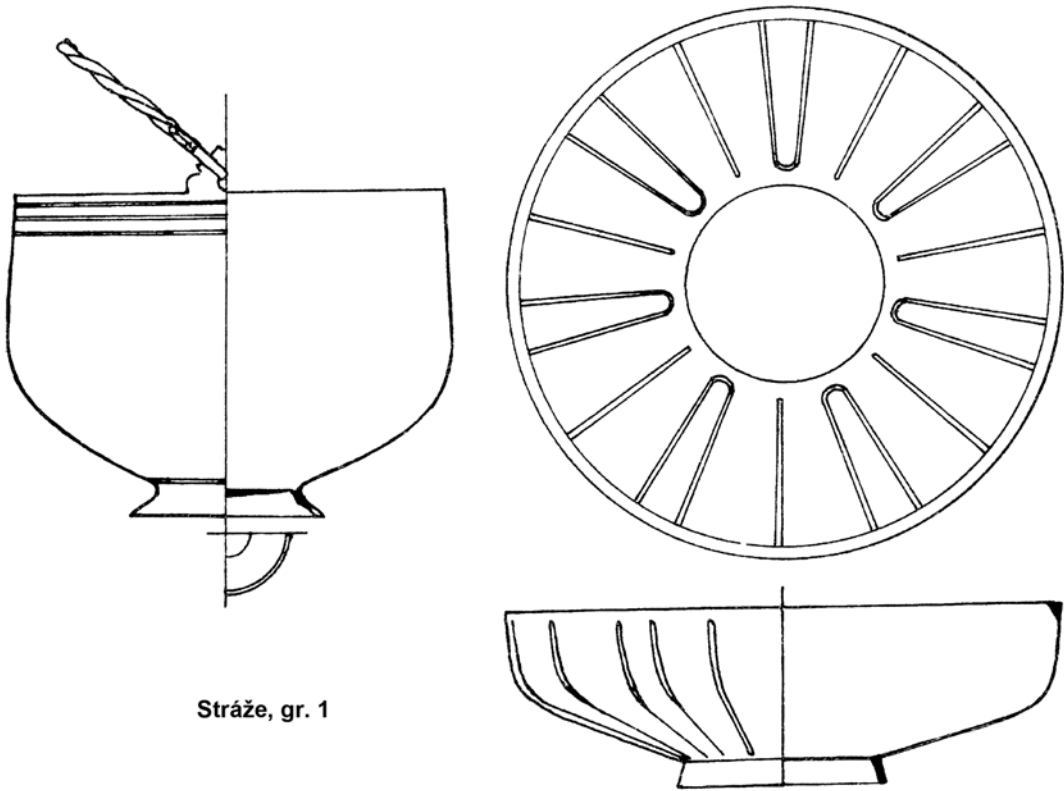

Fig. 5: Stráže, Grave 1. Selection of finds: bronze vessels (after KRASKOVSKÁ 1978).



The majority of metal vessels from this timespan (C1b to C3/D1) come from the richly furnished inhumation graves in Krakovany-Stráže graves I and II (Fig. 5, Pl. 6/2; ONDROUCH 1957; KLČO – KRUPA 2003; QUAST 2009; KOLNÍK 2010), Ostrovany (Pl. 6/3; PROCHÁSZKA 2006) and Cejkov (BENINGER 1931). These sites can be further supplemented with the preliminarily published plundered sumptuous grave from Poprad-Matejovce (LAU – PIETA 2014). The presence of metal vessels in the above-mentioned graves was explained by E. Krekovič (2014, 17) by a hypothetical stabilisation of social situation of the Quadi and concentration of power in families of barbarian leaders. Nevertheless, as was already indicated by J. Dobiáš (1964, 273–275), a stable social situation can hardly be envisaged in the first third of the 3rd century. The evidence on our disposal testifies of rivalry between individual members of elite as it was before. The information on further development is not sufficient. The evidence becomes more plentiful only after the mid-4th century when it permits us to perceive an intricate structure of Quadic elite (DOBIÁŠ 1964, 277–279). The emergence of sumptuous burials can thus most probably be explained similarly as it was in preceding periods (see above). A crucial role, besides diplomatic gifts, may have been played by the incursions into Roman territory.

At this place we cannot pay more attention to individual types of vessels due to the extent constraints, but we add some comments to new research approaches and the general interpretation of the occurrence of metal vessels in the Barbaricum.

Any further study of the graves from Stráže is further complicated by the incompleteness of the find assemblages (KOLNÍK 2010, 615–621). The case of the Ostrovany collection is similar (PROCHÁSZKA 2006; KOLNÍK 2010, 629). The questions as to whether the vessel sets were used in Roman way are therefore difficult to answer. Despite this we can trace the following trends. During the Late Roman Period, vessels which can be considered typical of dining sets prevail in the equipment of sumptuous graves from the Middle Danube region. Though skyphoi (Pl. 6/2, 3) also occur, they are only antiquities from the 1st half of the 2nd century. In the territory of Roman Empire, glass drinking vessels become very popular. This trend corresponds well to their occurrence in the graves from Stráže and Ostrovany, where several of them appear (QUAST 2009, 28) and support the considerations about the use of drinking sets in funerary feasts. Glass horns which are known from the European Barbaricum may have been produced in Rhineland for barbarian needs as well (NOWAKOWSKI 2012, 102).

Basing on the finds from barbarian settlements in Saxony-Anhalt and Thuringia (the sites of Grossjena and Neunheilingen) and from sumptuous graves we can distinguish two main ways of perception and use of metal vessels in the Barbaricum. Evidence for secondary use of metal vessels, such as their smelting for production of local items, shows that the approach of the barbarians to metal vessels at that time may also have been determined by their effort targeted at acquisition of metal for the production of, for example, brooches or belt components. M. Becker (2003) supposed that a considerable volume of Germanic objects (pins, fittings, etc.) were made from Roman artefacts. This author argues that even the artefacts which were highly valued in the Roman Empire may have become just a source of metal³ or were further reshaped in the barbarian milieu. We can give an example from the sumptuous grave from Gommern – a precious shield boss which was manufactured from a silver bowl. Similar approach was employed also in the wooden buckets from the richly furnished Grave II from Sackrau/Zakrzów (QUAST 2009, 17, Abb. 25). Their metal fittings were made from imported Roman bronze vessels. These selected examples show that the barbarians used metal vessels according to their current social needs. From Germanic settlements in Central Germany we

3 This assumption, however, must be still verified because M. M. Mango (1995, 81) proved accumulation of high-quality Roman silver items by the barbarians in the Late Antiquity.



know fragments of melted vessels, which are not very frequent in graves. In conclusion, it becomes evident that graves contain only selected types of metal ware (BECKER 2009, 365).

The state of our knowledge on metal vessels from barbarian settlements of the Late Roman to Final Roman Period in the Middle Danube region is not yet very satisfactory. This is to a certain extent most probably caused by the fact that new assemblages obtained with the help of metal detectors have not been published. The published older finds of fragments of metal vessels from the territory of Lower Austria north of the Danube, discovered by cooperating amateur archaeologists, are not very numerous (JÍLEK 2012, 94–95). The situation in Slovakia is similar. Older, not very numerous, finds were summarised most recently by E. Hrnčiarik (2013, e.g. 84, 138, Taf. XXXVII: 1280, 2034). Interesting among the recent finds is a part of a silver vessel with handle which is terminated with a feline head and reminds of handle attachments on the bowls of the type Eggers 83 from the settlement at Hamuliakovo (IVÁN – ÖLVECKÝ 2014, 216, Kép. 9:7). As a result, we cannot yet critically decide whether the situation in the Middle Danube region was similar to that in Central Germany. A hint might be provided by small parts of silver vessels from Beckov in Southwest Slovakia. These objects were dated, based on other finds, to the Migration Period (TURČAN 2014, 447–448, 450, Obr. 2:5, 6, 10) and represent a so far isolated example. With some degree of caution they might serve as evidence for recycling of Roman silver. From the same site comes also a part of a rectangular silver bar (TURČAN 2014, Obr. 2:7), which reminds of the newly published silver ingots from the Moravian and Bohemian territory (DROBERJAR 2014b, 140–141, Obr. 7).

We can conclude that sumptuous funerary assemblages of that time certainly resulted from intentional barbarian selection. They reflect mainly traditions, rather than directly the state of things (BECKER 2009, 364). Rich funerary assemblages regularly contain ladle and strainer sets of the type Eggers 161, Hemmoor buckets and basins with movable handles of Eggers' type 83 (QUAST 2009, 17–18, Abb. 26). These groups of finds may be regarded as manifestations of luxury and according to D. Quast they might signify the adoption of selected Roman customs such as hand washing before a feast. This is also indicated by a joint occurrence of a jug with narrow neck of Eggers' type 127 and a bowl with solid horizontal handle in the second grave from Stráže. This set might, however, also be a survival of the Early Roman Period tradition of the burial deposition of such similar pairs of vessels.

More recently D. Quast (2011, 263–265) pointed out another way of reception of luxurious metal vessels which is reflected by the richly furnished graves of barbarian leaders: the valuables as considered as parts of family treasures. The main characteristics of these treasures are thus wealth-opulence and family tradition (QUAST 2011, 263). They can contain both antiquities (tradition) and objects manufactured at the time of funeral (opulence – wealth). The antiquities are then interpreted by the author mainly, but not exclusively, as 'objects of memory', which remind of famous acts of the ancestors and of the deceased himself. The occurrence of the 'objects of memory' may in some cases be traced back to the Early Roman Period, with certainty to the Middle Roman Period, as it is proved by, for example, the old-fashioned pieces from the royal tomb of Mušov. Among these prevail luxurious vessels (e.g. the *lanx* from Grave II at Stráže, a golden beaker of barbarian origin from the burial at Ostrovany) made of silver and gold. In the Late Antiquity, golden objects were mainly intended for the Emperor and his family, in the non-Roman world then for the uppermost class (MANGO 1995, 77, 79). The use of silver vessels in the Empire depended on their quality. M. M. Mango (1995, 77, 79) has proved that ordinary sets have been used by soldiers, merchants, officials and inhabitants of towns. In Germanic milieu, silver vessels were mainly used by the elite, inclusive of the highest military circles. Besides objects from precious metals it is also necessary to mention unique artefacts made of bronze, for example the cauldron from Mušov (Fig. 4:1), folding tripods and tables.



In the Late Roman Period these artefacts of particularly high quality increased the prestige of funerary equipment. Thanks to this prestige and to memories of the famous times of the ancestors, these graves then stand out among the others, though they most probably do not have any other purpose (BECKER 2003, 286).

CONCLUSION

It follows from the above overview that in the barbarian society the approach to metal vessels underwent a gradual development. In the Early Roman Period, bronze vessels were particularly widespread in both the richer cremation graves and in the inhumation graves. In the Middle Danube region, deposition of silver vessels is limited to richly furnished inhumation burials, with exceptions such as the burial from Wulzeshofen. The inflow of metal vessels was associated with political and trading relations to the Roman Empire. It is hypothetically also possible that some types of bronze vessels, used by the Roman army (HRNČIARIK – BAŇOVIČ 2014, 56, Obr. 3:A, B), may have reached the Barbaricum together with veterans of the auxiliary forces (JÍLEK 2012, 94). Luxurious vessels, especially those made of silver, can be considered diplomatic gifts.

The adoption of Roman dining customs cannot be evidenced in its whole complexity on the basis of funerary equipment. Only some components of the dining sets were widely used, such as washing kits and the ladle and strainer pair. It comes to light that these customs were rather gradually simplified, the crucial role in this process being played by barbarian customs and the effort of representation. From the Middle Roman Period, also the ‘memory’ symbolism of some luxurious items might be taken to consideration according to D. Quast (2011). Funerary equipment thus reflect ideas connected with funeral rituals and demonstration of wealth rather than a faithful image of the living culture of barbarian communities (in detail and with further literature see HOFMANN 2013, 273–274, 282).

BIBLIOGRAPHY

- BARTUS, D. 2011: Roman Figural Bronzes from Brigetio: Preliminary Notes. *Anodos. Studies of Ancient World* 10, 17–27.
- BECKER, M. 2003: Klasse und Masse – Überlegungen zu römischem Sachgut im germanischen Milieu. *Germania* 81, 277–288.
- BECKER, M. 2009: Germanische Eliten der späten Römischen Kaiserzeit. In: Burmeister, S. (ed.): *2000 Jahre Varusschlacht-Konflikt*. Stuttgart, 358–369.
- BECKER, M. 2010: *Das Fürstengrab vom Gommern*. Veröffentlichungen des Landesamtes für Denkmalpflege und Archäologie Sachsen-Anhalt-Landesmuseum für Vorgeschichte 63. Halle an der Saale.
- BELJAK, J. – KOLNÍK, T. 2006: Germánske hroby z Čaky a Gbeliec. Príspevok k osídleniu juhozápadného Slovenska v dobe rímskej. *Slovenská Archeológia* LIV/1, 57–94.
- BELJAK, J. – BŘEZINOVÁ, G. – VARSÍK, V. eds. 2010: *Archeológia barbarov 2009*. Archaeologica Slovaca Monographiae. Communicationes X. Nitra.
- BENINGER, E. 1931: Der Wandalenfund von Czéke-Cejkov. *Annalen des Naturhistorischen Muzeum in Wien* 45, 183–224.
- BENINGER, E. 1932: Zwei germanische Funde von Wulzeshofen in Niederösterreich. *Wiener Prähistorische Zeitschrift* 19, 215–238.



- BOTT, H. 1976–1977: Zur Datierung der Funde aus Hammersdorf (Ostpreussen). *Jahrbuch des Römisch-Germanischen Zentralmuseums Mainz* 23–24, 139–153.
- BOUZEK, J. 1994: Die neue römischen und barbarischen Funde und Befunde in Südmähren und Niederösterreich: Historische Interpretationsmöglichkeiten. In: Friesinger, H. – Tejral, J. – Stuppner, A. (eds.): *Markomannenkriege – Ursachen und Wirkungen*. Spisy Archeologického ústavu AV ČR Brno 1. Brno, 173–178.
- BOUZEK, J. 2000: The Protomae and Busts of Bronze Vessels and Utensils in the Mušov Grave. In: Bouzek, J. – Friesinger, H. – Pieta, K. – Komoróczy, B. (eds.): *Gentes, Reges, und Rom. Auseinandersetzung – Anerkennung – Anpassung. Festschrift für J. Tejral zum 65. Geburtstag*. Spisy Archeologického ústavu AV ČR Brno 16. Brno, 117–120.
- BROTHER, S. 2005: Acculturation and Ethnogenesis along the Frontier. Rome and the Ancient Germans in an Archaeological Perspective. In: Curta, F. (ed.): *Borders, Barriers, and Ethnogenesis. Frontiers in Late Antiquity and the Middle Ages*. Studies in the Early Middle Ages 12. Turnhout, 139–171.
- BRAUND, D. 1989: Ideology, Subsidies and Trade: the King on the Northern Frontier Revisited. In: Barrett, J.C. – Fitzpatrick, A.P. – Macinnes, L. (eds.): *Barbarians and Romans in North-West Europe from Later Republic to Late Antiquity*. BAR International series 471. Oxford, 14–26.
- BROGAN, O. 1936: Trade between the Roman Empire and the Free Germans. *The Journal of Roman Studies* 26/2, 195–222.
- ČIŽMÁŘ, M. 1998: Zum Vorkommen von Bernstein in der Latène- und Römerzeit in Mähren. In: ČIŽMÁŘOVÁ – MĚCHUROVÁ eds. 1998, 35–44.
- ČIŽMÁŘOVÁ, J. – MĚCHUROVÁ, Z. eds. 1998: *Peregrinatio Gothica – Jantarová stezka*. Supplementum ad Acta musei moraviae scienties sociales LXXXII. Brno.
- DOBIÁŠ, J. 1964: *Dějiny československého území před vystoupením Slovanů*. Praha.
- DIVAC, G. 2013: Jantar ve sbírkách Oddělení pravěku a antického starověku Národního muzea v Praze. *Praehistorica XXXI/1*, 99–277.
- DROBERJAR, E. 1999: *Dobřichov-Piřhora. Ein Brandgräberfeld der älteren römischen Kaiserzeit in Böhmen. (Ein Beitrag zur Kenntnis des Marbod-Reichs)*. Fontes Archaeologici Pragenses 23. Praha.
- DROBERJAR, E. 2009: Contributions to the History and Archaeology of the Maroboduus Empire. In: SALAČ – BEMMANN eds. 2009, 149–202.
- DROBERJAR, E. 2014a: Bohatý labsko-germánský kostrový hrob lübsowského typu z Prahy-Bubenče (hrob III). Nové poznatky k interpretaci nálezu z roku 1948. *Archaeologica Pragensia* 22, 397–443.
- DROBERJAR, E. 2014b: Stříbro na žárovém pohřebišti z doby římské v Jevíčku. In: KOMORÓCZY ed. 2014, 133–148.
- ELSCHEK, K. 2002: Ein Hortfund von römischen Bronzgefäßbruchstücken: neue Grab und Siedlungsfunde aus Zohor. In: Kuzmová, K. – Rajtár, J. – Pieta, K. (eds.): *Zwischen Rom und dem Barbaricum. Festschrift für Titus Kolník zum 70. Geburtstag*. Nitra, 245–261.
- ELSCHEK, K. 2009: Der slowakische Abschnitt der Bernsteinstrasse im 1. Jahrhundert n. Ch. nördlich von Carnuntum und neue Grabfunde von Zohor. In: SALAČ – BEMMANN eds. 2009, 239–250.
- ELSCHEK, K. 2013: Zohor – Ein neues Fürstengrab der „Lübsow-Gruppe“ und Brandgräber mit Edelmetallbeigaben aus Zohor (Westslowakei). In: Hardt, M. – Tamáska, O.H. (eds.): *Macht des Goldes, Gold der Macht. Herrschafts und Jenseitsrepräsentation zwischen Antike und Frühmittelalter im mittleren Donauraum*. Forschungen zu Spätantike und Mittelalter 2. Weinstadt, 91–123.
- ELSCHEK, K. – RAJTÁR, J. – VARSÍK, V. 2011: Sepulkrálný objekt zo Zohora. In: Droberjar, E. (ed.): *Hroby a pohřebišť Germánů mezi Labem a Dunajem*. Archeologie barbarů 2010. Olomouc, 133–151.
- GRALAK, T. 2012: *Influence from Danubian Zone of the Barbaricum on the territory of Poland in Late Antiquity*. Studia Archeologiczne XLII. Wrocław.
- GUZZO, P.G. 2006 ed.: *Argenti a Pompeii*. Milano.
- HAJNALOVÁ, M. – VARSÍK, V. 2010: Kvádské rolnictvo na Slovensku z pohľadu archeológie a archeobotaniky. In: BELJAK – BŘEZINOVÁ – VARSÍK eds. 2010, 181–224.
- HARHOIU, R. 1977: *The Treasure from Pietroasa Romania*. BAR Supplementary Series 24. Oxford.



- HEČKOVÁ, J. 1982: Podiel výrobných centier rímskych provincií na spoločensko-ekonomickom vývoji naddunajského barbarika vo svetle rímskych importov. *Slovenská archeológia* 30/1, 5–77.
- HOFMANN, K. 2013: Gräber und Totenrituale: Zu aktuellen Theorien und Forschungsansätzen. In: Eggert, M.K.H. – Veit, U. – Augstein, M. (eds.): *Theorie in der Archäologie. Zur jüngeren Diskussion in Deutschland*. Tübinger Archäologische Taschenbücher 10. Münster, 269–298.
- HRNČIARIK, E. 2013: *Römisches Kulturgut in der Slowakei. Herstellung, Funktion, und Export römischer Manufakturzeugnisse aus den Provinzen in der Slowakei*. Universitätsforschungen zur Prähistorischen Archäologie 222. Bonn.
- HRNČIARIK, E. – BAŇOVIČ, J. 2014: *Vyobrazenia nádob na Trajánovom stĺpe a stĺpe Marka Aurélia*. Zborník Slovenského národného múzea. Supplementum 8, 51–59.
- IBRAGIMOW, K. – SCHÖNFELDER, M. 2014: Endlich wieder Geschenke! Römische Staatsgeschenke in Gräbern der vorrömischen Eisenzeit und der frühen römischen Kaiserzeit im Vergleich. *Honesta Missione. Festschrift für Barbara Pferdehirt*. Monographien des Römisch-Germanischen Zentralmuseums 100. Mainz, 109–120.
- IVÁN, R. – ÖLVECKY, R. 2014: Germán települések a közép Duna menti római határvidéken. In: Balázs, P. (ed.): *FIRKak III. Fiala Római Koros Kutatók III. konferenciakötete*. Szombathely, 205–220.
- JÍLEK, J. 2012: *Bronzové nádoby z doby římské z Moravy a naddunajské části Dolního Rakouska*. Pardubice.
- KLČO, M. – KRUPA, V. 2003: *German Graves from Roman Times from Krakovany-Stráže*. Piešťany.
- KOLNÍK, T. 1961: Pohrebisko v Bešeňově (príspevok k štúdiu doby rímskej na Slovensku). *Slovenská archeológia* IX/1–2, 219–300.
- KOLNÍK, T. 1975: Žiarové pohrebisko z neskorej doby rímskej a zo začiatku sťahovania národov v Čiernom Brode. *Slovenská archeológia* 23, 341–378.
- KOLNÍK, T. 1977: Anfänge der Germanischen Besiedlung in der Südwestslowakei und das Regnum Vannianum. In: Chropovský, B. (ed.): *Symposium Ausklang der Latène-Zivilisation und Anfänge der germanischen Besiedlung im mittleren Donauegebiet*. Bratislava, 143–171.
- KOLNÍK, T. 1980: *Römerzeitliche Gräberfelder in der Slowakei*. Archaeologica Slovaca Fontes XIV. Bratislava.
- KOLNÍK, T. 1984: *Rímske a germánske umenie na Slovensku*. Bratislava.
- KOLNÍK, T. 2004: Die mitteldanubische Barbaricum – eine Brücke zwischen Zentrum und Peripherie am Beispiel medizinischer Messerfunde. In: Friesinger, H. – Stuppner, A. (eds.): *Zentrum und Peripherie – gesellschaftliche Phänomene in der Frühgeschichte*. Wien, 195–210.
- KOLNÍK, T. 2010: Stráže-Krakovany a Ostrovany/Osztropataka. Poznámky k novým súvislostiam a nálezom z hrobov germánskej elity. In: BELJAK – BŘEZINOVÁ – VARSÍK eds. 2010, 615–638.
- KOMORÓCZY, B. ed. 2014: *Sociální diferenciace barbarských komunit. Archeologie barbarů 2011*. Spisy Archeologického ústavu AV ČR Brno 44. Brno.
- KRASKOVSKÁ, L. 1959: Hroby z doby rímskej v Zohore. *Slovenská archeológia* 7, 94–143.
- KRASKOVSKÁ, L. 1978: *Roman Bronze Vessels from Slovakia*. BAR International series Suppl. 44. Oxford.
- KREKOVIČ, E. 1992: Zur Datierung der Fürstengräber der römischen Kaiserzeit in der Slowakei. In: Godłowski, K. – Madyda-Legutko, R. (eds.): *Probleme der relativen und absoluten Chronologie von der Latènezeit bis zum Frühmittelalter*. Kraków, 55–68.
- KREKOVIČ, E. 2006: Ranking and Roman Ware among the Germans: the Case of Slovakia. *Eirene* XLII, 130–134.
- KREKOVIČ, E. 2007: Príspevok k sociálnej štruktúre Germánov. Žiarové pohrebiská juhozápadného Slovenska. *Zborník filozofickej fakulty Univerzity Komenského. Musaica* XXV, 91–97.
- KREKOVIČ, E. 2008: Víno, ženy a bronzové nádoby. In: *Konferencie o pohřebním ritu, muž a žena v pohřebním ritu*. Acta Archaeologica Opaviensia 3. Opava, 113–116.
- KREKOVIČ, E. 2009: Počiatky doby rímskej na Slovensku. In: Karwowski, M. – Droberjar, E. (eds.): *Powiązania i kontakty w świecie barbarzyńskim. Archeologia Barbarzyńców 2008*. Collectio Archaeologica Resoviensis XIII. Rzeszów, 177–185.



- KREKOVIČ, E. 2011: Romans and Barbarians: Some Remarks on Cultural Contact, Influence and Material Culture. In: De Sena, E.C. – Dobrzanska, H. (eds.): *The Roman Empire and Beyond: Archaeological and Historical Research on the Romans and Native Cultures in Central Europe*. BAR International Series 2236. Oxford, 81–84.
- KREKOVIČ, E. 2014: Sociálna diferenciácia všeobecne a u Germánov zvlášť. In: KOMORÓCZY ed. 2014, 13–18.
- KRIERER, K.R. 2002: Germanenbüsten auf dem Kessel. Die Henkelattaschen des Bronzekessels. In: PEŠKA – TEJRAL eds. 2002, 367–385.
- KUNOW, J. 1983: *Die römische Import in der Germania Libera bis zu den Markomannenkriege*. Studien zu Bronze- und Glassgefäße. Neumünster.
- KÜNZL, E. 1988: *Germanische Fürstengräber und römisches Silber*. Jahrbuch der Lauenburgischen Akademie für Wissenschaft und Kultur 1, 31–53.
- KÜNZL, S. 1997: Schwechat (Niedrösterreich) – ein germanisches Grab der Stufe Eggers B1. *Archäologisches Korrespondenzblatt* 27, 145–158.
- KÜNZL, S. 2002: Römische Silberbecher bei den Germanen. Das übrige Silbergeschirr: Schälchen und Schälchengriffe, Gefäßfüßchen und Löffel. In: PEŠKA – TEJRAL eds. 2002, 329–355.
- KÜNZL, S. 2010: Römische Metallobjekte. In: Becker, M. (ed.): *Das Fürstengrab von Gommern*. Veröffentlichungen des Landesamtes für Denkmalpflege und Archäologie Sachsen-Anhalt-Landesmuseum für Vorgeschichte 63. Halle an der Saale, 171.
- KÜNZL, S. – KÜNZL, E. 2002: Die Bronzegefäße. In: PEŠKA – TEJRAL eds. 2002, 357–366.
- LAU, N. – PIETA, K. 2014: Das Grab von Poprad-Matejovce in der Slowakei – Anlage. Konstruktion und Ausstattung eines frühvölkerwanderungszeitlichen Kammergrabes. In: Abegg-Wigg, A. – Lau, N. (eds.): *Kammergräber im Barbaricum – Zu Einflüssen und Übergangssphänomenen von der vorrömischen Eisenzeit bis in die Völkerwanderungszeit*. Internationale Tagung, Schleswig, 25.–27. November 2010. Schriften des Archäologischen Landesmuseums Ergänzungsreihe 9. Neumünster – Hamburg, 343–364.
- LAUERMANN, E. 1994: Ein reich ausgestattetes germanisches Brandgrab aus Mannersdorf an der March, VB Gänserndorf, Niederösterreich. *Fundberichte Österreich* 33, 281–285.
- LOBODA, I.I. – PUZDROVSKIJ, A.E. – ZAJCEV, J.P. 2002: Prunkbestattungen des 1. Jh. n. Chr. in der Nekropole Ust'-Alma auf der Krim. *Euroasia Antiqua* 8, 295–345.
- MĄCZYŃSKA, M. – RUDNICKA, D. 2004: Ein Grab mit römischen Importen aus Czarnówko. Kr. Lębork (Pommern). *Germania* 82, 397–429.
- MANGO, M.M. 1995: Silver among the Romans and among the Barbarians. In: Vallet, F. – Kazanski, M. (eds.): *La noblesse romaine et les chefs barbares du III^e au VII^e siècle*. Paris, 77–83.
- MRÁV, Z. 2013: Eiserne Klappstühle aus Kaiserzeitlichen Bestattungen der einheimischen Elite in Pannonien. Zu den Beigaben der Bade- und Reinigungsgarnitur pannonischer Wagengräber. *Archaeologiai Értesítő* 138, 105–144.
- NAGY, M. 1998: Routes in the Carpathian Basin and the Interaction between Romans and Barbarians. In: ČIŽMÁŘOVÁ – MĚCHUROVÁ eds. 1998, 151–162.
- NENOVA-MERDJANOVA, R. 2002: Bronze Vessels and the Toilette in Roman Times. In: Mattusch, C.C. – Brauer, A. – Knudsen, S.E. (eds.): *From the Parts to the Whole* 2. Acta of the 13th International Bronze Congress held at Cambridge, Massachusetts, May 28–June 1, 1996. *Journal of Roman Archaeology Suppl.* 39, 200–204.
- NENOVA-MERDJANOVA, R. 2011: Production and Consumption of Bronzework in Roman Thrace. In: Haynes, I.P. (ed.): *Early Roman Thrace. New Evidence from Bulgaria*. *Journal of Roman Archaeology. Suppl.* 82, 115–134.
- NOVOTNÝ, B. 1955: Hrob velmože z počátků doby římské v Praze-Bubenči. *Památky archeologické* 46, 227–264.
- NOVOTNÝ, B. 1995: *Slovom a mečom. Slovensko v rímskej dobe*. Martin.
- NOWAKOWSKI, W. 2012: Auf der Suche nach dem „Gold des Nordes“. Rom, die Barbaren und die Bernsteinstrasse. *Światowit VII (XLVIII)*, fas. B/2006–2008, 95–107.
- NUBER, H.U. 1972: Kanne und Griffschale. Ihr Gebrauch im täglichen Leben und die Beigabe in Gräbern der römischen Kaiserzeit. *Bericht der Römisch Germanischen Kommission* 53, 1–232.
- ONDROUCH, V. 1957: *Bohaté hroby z doby rimskej na Slovensku*. Bratislava.



- PELIKÁN, O. 1977: Protohistorie ČSSR ve světle antických písemných pramenů. *Listy filologické* 100, 2–13.
- PESCHEL, K. 1995: Beobachtungen an zweigliedringen Kesseln mit Eisernen Rand. *Alt-Thüringen* 29, 69–94.
- PEŠKA, J. – TEJRAL, J. 2002: *Das Königsgrab aus der älteren römischen Kaiserzeit von Mušov, Mähren (Tschechische Republik)*. Monographien des Römisch-Germanischen Zentralmuseums 55. Mainz.
- PITTS, L.F. 1989: Relation between Rome and the German ‘Kings’ on the Middle Danube in the First to Fourth Centuries A.D. *The Journal of Roman Studies* 79, 45–58.
- PROCHÁSZKA, P. 2006: *Das Vandalische Königsgrab von Osztrópataka (Ostrovany, SK)*. Budapest.
- QUAST, D. 2009: *Wanderer zwischen den Welten. Die germanischen Prunkgräber von Stráže und Zakrzów*. Mainz.
- QUAST, D. 2011: Symbolic Treasures in Barbarian Burials (3rd–7th century AD). In: Baldini Lippolis, I. – Lina Morrelli, A. (eds.): *Oggetti-simbolo: produzione, uso e significato nel mondo antico*. Ornamenta 3. Bologna, 253–268.
- RUTTKAY, M. 2004: Unikátny nález z doby rímskej v Dvorech nad Žitavou. *Archeologické výskumy a nálezy na Slovensku 2003*, 155–156.
- SALAČ, V. – BEMMANN, J. eds. 2009: *Mitteleuropa zur Zeit Marbods*. Praha – Bonn.
- SCHULZ, V. 1885: Hrob u Zlivi. *Památky archeologické* 13, 65–80.
- SCHUSTER, J. 2010: *Lübsow. Älterkaiserzeitliche Fürstengräber im nördlichen Mitteleuropa*. Bonner Beiträge zur Vor- und Frühgeschichtlichen Archäologie 12. Bonn.
- SIMONENKO, A. – MARČENKO, I.I. – LIMBERIS, N. 2008: *Römische Importe in sarmatischen und maiotischen Gräbern zwischen unteren Donau und Kuban*. Archäologie in Eurasien 25. Mainz.
- SKOWRON, J. 2015: Relikty warsztatów rzemieślniczych w kulturze przeworskiej. Zarys problematyki. In: Michałowski, A. – Teska, M. – Żółkiewski, M. (eds.): *Viator per devia scientiae itinera*. Seria Archeologia 53. Poznań, 51–70.
- STEUER, H. 1982: *Frühgeschichtliche Socialstrukturen in Mitteleuropa*. Göttingen.
- STEUER, H. 1992: Interpretationsmöglichkeiten archäologischer Quellen zum Gefolgschaftsproblem. In: Neumann, G. – Seemann, H. (eds.): *Beiträge zum Verständnis der Germania des Tacitus*. Bericht über die Kolloquien der Kommission für die Altertumskunde Nord- und Mitteleuropas im Jahre 1986 und 1987. Göttingen, 203–257.
- STEUER, H. 1994: Archäologie und germanische Sozialgeschichte – Forschungstendenzen in den 1990er Jahren. In: Düwel, K. (ed.): *Runische Schriftkultur in kontinental-skandinavischer und -angelsächsischer Wechselbeziehung*. Internationales Symposium in der Werner-Reimers-Stiftung vom 24.–27. Juni 1992 in Bad Homburg. Berlin – New York, 10–55.
- STEUER, H. 2006: Fürstengräber, Adelsgräber, Elitegräber. Methodisches zur Anthropologie der Prunkgräber. In: von Carnap-Bornheim, C. – Krausse, D. – Wesse, A. (eds.): *Herrschaft-Tod-Bestattung*. Universitätsforschungen zur Prähistorischen Archäologie 139, 11–25.
- TAUSEND, K. 2009: *Im Inneren Germaniens. Beziehungen zwischen den germanischen Stämmen vom 1. Jh. v. Ch. bis 2. Jh. n. Ch.* Geographica Historica 25. Stuttgart.
- TEJRAL, J. 1986: Importe. In: Oliva, P. (ed.): *Tabula Imperii Romani* M33. Praha, 103–109.
- TEJRAL, J. 2001: Die germanische Silberfibel von Mušov und ihr archäologisch-historisches Umfeld. *Slovenská archeológia* 49, 203–247.
- TEJRAL, J. 2006: Die germanische Giessereiwerkstatt in Pasohlávky (Bez. Břeclav). Ein Beitrag zur Frage der Fernhandels- und Kulturbeziehungen nach den Markomannenkriegen. *Památky archeologické* XCVII, 133–170.
- TEJRAL, J. 2009: Das Gebiet nördlich der mittleren Donau zur Zeit Marbods. In: SALAČ – BEMMANN eds. 2009, 149–202.
- TURČAN, V. 2014: Nové nálezy z juhozápadného Slovenska zo stahovania národov. In: KOMORÓCZY ed. 2014, 447–452.
- VOSS, H.U. 2006: Hagenow in Mecklenburg – ein frühkaiserzeitlicher Bestattungsplatz und Aspekte der römisch-germanischen Beziehungen. *Bericht der Römisch Germanischen Kommission* 86, 19–59.



Voss, H.U. 2008: Zwischen Vannius-Reich und Vimose. Die elitären Krieger von Hagenow. In: Abegg-Wigg, A. – Rau, A. (eds.): *Aktuelle Forschungen zu Kriegsbeuteopfern und Fürstengräbern im Barbaricum*. Neumünster, 253–277.

WIELOWIEJSKI, J. 1981 ed.: *Późny okres laténski i okres rzymski*. Prehistoria ziem Polskich V. Wrocław – Warszawa – Kraków – Gdańsk.

WIELOWIEJSKI, J. 1989: Die römerzeitlichen Silbergefäße in Polen. *Bericht der Römisch Germanischen Kommission* 70, 191–241.

Jan Jílek

Univerzita Pardubice, Fakulta filozofická
Ústav historických věd
Studentská 84, CZ-532 10, Pardubice

Východočeské muzeum v Pardubicích
Archeologické oddělení
Zámek č. p. 4, CZ-530 02, Pardubice
mitridates@post.cz



Pl. 5/1: Němčice, Moravia. Imported glass beads, 3rd century BC.



Pl. 6/1: Zohor - Grave 5. Silver kantharos (after KOLNÍK 1984).

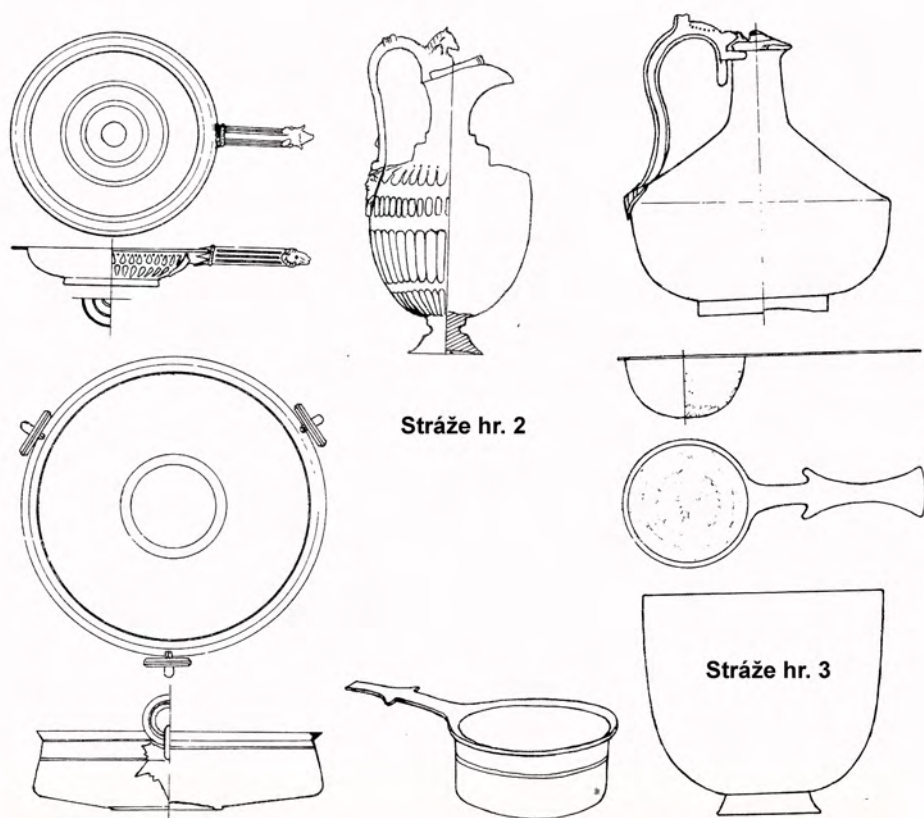

Pl. 6/2: Stráže - graves 2 and 3. Selection of finds - metal vessels (after KRASKOVSKÁ 1978 and NOVOTNÝ 1995).



Pl. 6/3: Royal tomb of Ostrovany. Silver vessels, skyphos (top), plate (bottom) (after PROCHÁSZKA 2006).